

# EVOLUTION

## Selection and Ordering Guide

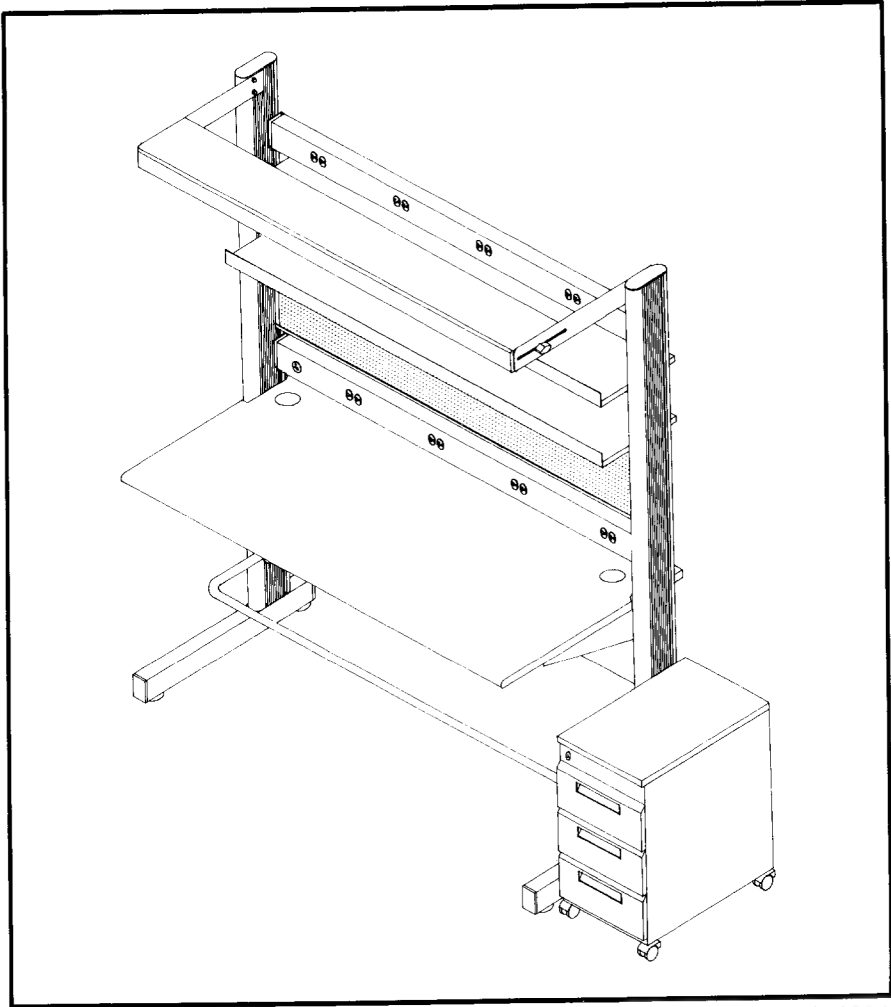

K E W A U N E E

# KEWAUNEE SCIENTIFIC CORPORATION

---

Serving the technical workplace since 1906.

Kewaunee offers a complete line of products to make your technical work environment more efficient and productive. Our "systems approach" to technical environment planning provides you with the expertise of our workstation professionals who draw more than 80 years of experience to design optimum and effective work places.

## TABLE OF CONTENTS

Product Vocabulary.....	2
How to Select, Specify and Order.....	3
Low Column Workstations.....	4
Mid Column Workstations.....	5
High Column Workstations.....	6
Double Sided Workstations.....	7
Corner Units.....	8-9
Bridge Units.....	10
System Shelving.....	11
System Storage.....	12
Overhead Storage.....	13
System Electrical.....	14
Utility Management Raceway.....	15-16
System Lighting.....	17
Mobile Carts.....	18
Mobile Pedestals.....	19
Bin Bars.....	19
Parts Bins.....	20
Tool Bars.....	21
Footrails.....	21
Tack Panels.....	22
Columns/Bases.....	22
Accessories.....	23
ESD Options.....	24

# PRODUCT VOCABULARY

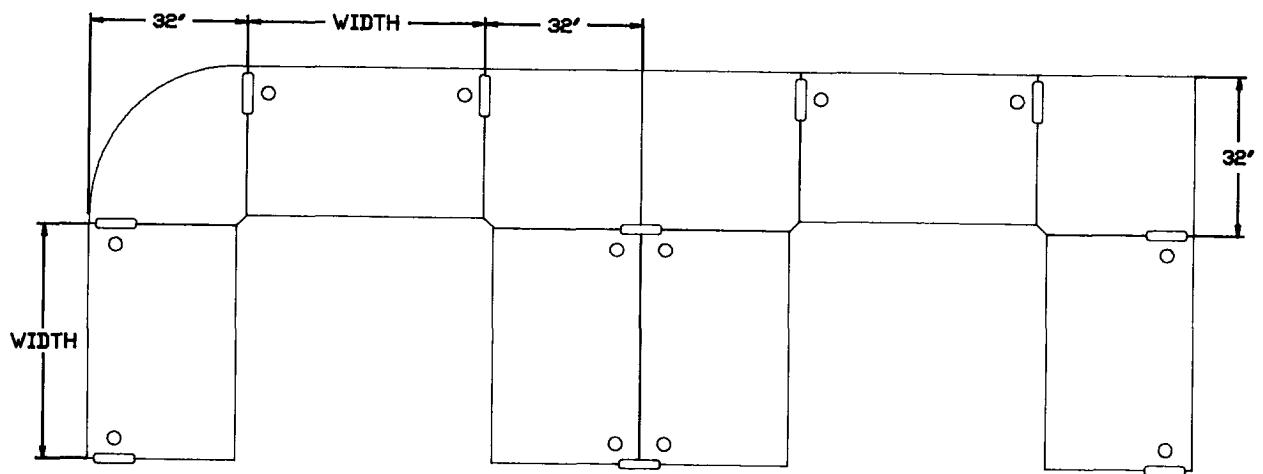
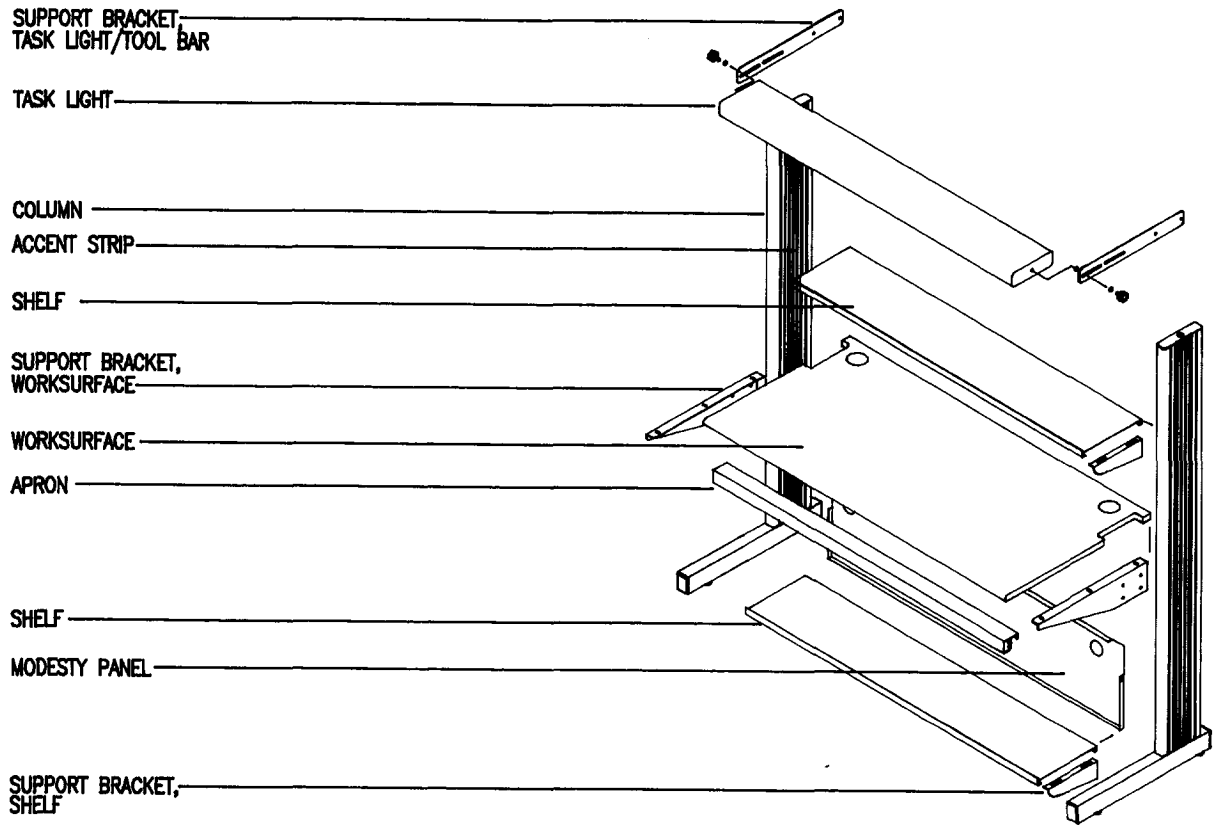

TYPICAL WORKSTATION LAYOUT

## HOW TO SELECT, SPECIFY AND ORDER

---

Kewaunee recommends the specifications of the room layout be determined in advance of ordering the actual workstations. The end result is a well planned production area that meets your requirements, saves money, and provides your personnel with an ergonomically designed productive work area.

### To Begin:

- (1) Measure the allocated space.
- (2) Determine personnel requirements.
- (3) Specify features important for operational requirements.

At any time, contact a local Kewaunee representative from a nationwide service network to provide you with assistance in determining your exact workstation requirements.

### Ordering a Workstation:

1. Select: Low Column Workstation  
Mid Column Workstation  
High Column Workstation  
Double-Sided Workstation
2. Determine the width of the workstation: 48", 60" or 72".  
Workstation width is measured from centerline of column to centerline of column.
3. Specify the color of the worksurface and accent strips for the workstation:

Example: Product Number 407304

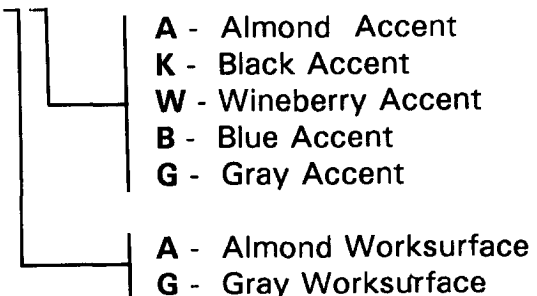

4. Specify the painted steel color: Sand Tan, Gray, White or Black  
Customized paint colors can be specified to meet your needs.
5. ESD workstations and bridge units are shown with standard workstations.  
ESD worksurface/accent strip colors are:  
**AA** - almond worksurface with almond accent  
**GG** - gray worksurface with gray accent
6. Select workstation accessories (lighting, shelving, corner units, storage...etc.).

# LOW COLUMN WORKSTATIONS

Basic Workstations include a front radius edge worksurface, (2) supporting columns with bases and glides. Worksurface support brackets, apron and modesty panel are also included.

Add-On Workstations include all items listed above except (1) supporting column and base. The Add-On Workstation shares the column and base from an existing adjacent Basic Workstation.

ESD Workstations are supplied with all grounding hardware and static dissipative laminate.

## Basic Workstations

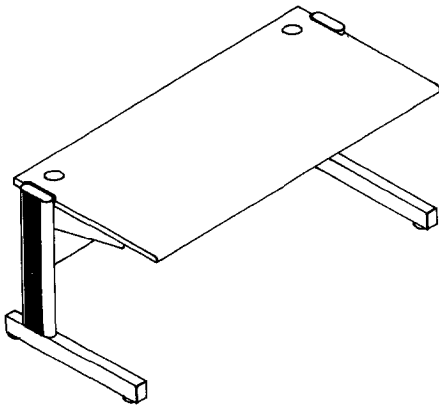

Maximum Height	Depth	Width	Standard*	ESD*	Approx. Weight
30"	30"	48"	407304__	407354__	123
		60"	407305__	407355__	138
		72"	407306__	407356__	153

## Add-On Workstations

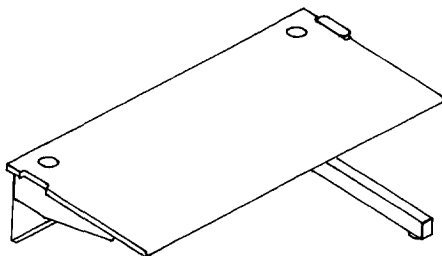

Maximum Height	Depth	Width	Standard*	ESD*	Approx. Weight
30"	30"	48"	407307__	407357__	104
		60"	407308__	407358__	119
		72"	407309__	407359__	134

\*Specify color preference with a suffix to the product number:  
 For Example, product number 407304\_\_ requires a worksurface color code **first**, and an accent color code **second**.

Worksurface Colors: A - Almond or G - Gray

Accent Colors: A - Almond, K - Black, W - Wineberry, B - Blue or G - Gray

ESD Worksurface/Accent Colors: AA - Almond or GG - Gray

# MID COLUMN WORKSTATIONS

Basic Workstations include a front radius edge worksurface, (2) supporting columns with bases and glides. Worksurface support brackets, apron and modesty panel are also included.

Add-On Workstations include all items listed above except (1) supporting column and base. The Add-On Workstation shares the column and base from an existing adjacent Basic Workstation.

ESD Workstations are supplied with all grounding hardware and static dissipative laminate.

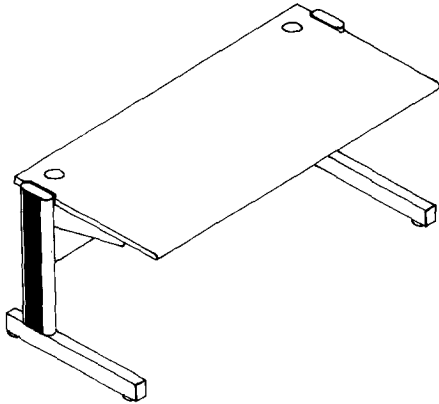

## Basic Workstations

Maximum Height	Depth	Width	Standard*	ESD*	Approx. Weight
36"	30"	48"	407314__	407364__	125
		60"	407315__	407365__	142
		72"	407316__	407366__	157

## Add-On Workstations

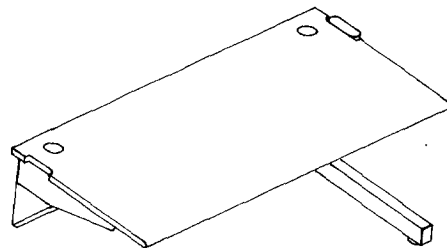

Maximum Height	Depth	Width	Standard*	ESD*	Approx. Weight
36"	30"	48"	407317__	407367__	106
		60"	407318__	407368__	121
		72"	407319__	407369__	136

\*Specify color preference with a suffix to the product number:  
For Example, product number 407304\_\_ requires a worksurface color code **first**, and an accent color code **second**.

Worksurface Colors: A - Almond or G - Gray

Accent Colors: A - Almond, K - Black, W - Wineberry, B - Blue or G - Gray

ESD Worksurface/Accent Colors: AA - Almond or GG - Gray

# HIGH COLUMN WORKSTATIONS

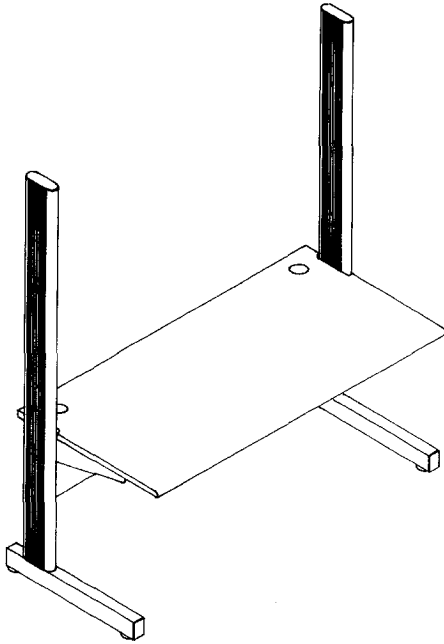

Basic Workstations include a front radius edge worksurface, (2) supporting columns with bases and glides. Worksurface support brackets, apron and modesty panel are also included.

Add-On Workstations include all items listed above except (1) supporting column and base. The Add-On Workstation shares the column and base from an existing adjacent Basic Workstation.

ESD Workstations are supplied with all grounding hardware and static dissipative laminate.

## Basic Workstations

Maximum Height	Depth	Width	Standard*	ESD*	Approx. Weight
76"	30"	48"	407324__	407374__	153
		60"	407325__	407375__	168
		72"	407326__	407376__	183

## Add-On Workstations

Maximum Height	Depth	Width	Standard*	ESD*	Approx. Weight
76"	30"	48"	407327__	407377__	119
		60"	407328__	407378__	135
		72"	407329__	407379__	149

\*Specify color preference with a suffix to the product number:  
For Example, product number 407304\_\_ requires a worksurface color code **first**, and an accent color code **second**.

Worksurface Colors: A - Almond or G - Gray

Accent Colors: A - Almond, K - Black, W - Wineberry, B - Blue or G - Gray

ESD Worksurface/Accent Colors: AA - Almond or GG - Gray

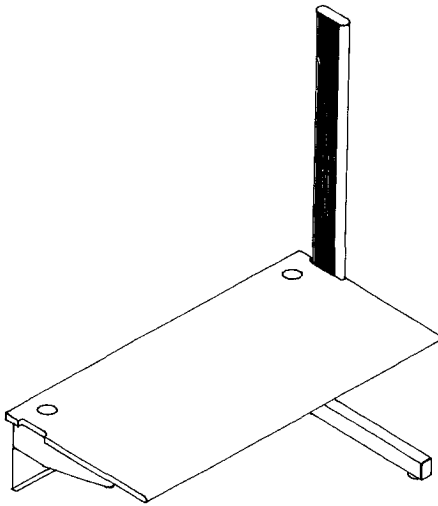

## DOUBLE-SIDED WORKSTATIONS

Basic Workstations include (2) front radius edge worksurfaces that share (2) supporting columns with bases and glides. (2) double-sided worksurface support brackets, (2) aprons and (2) modesty panels are also included.

Add-On Workstations include all items listed above except (1) supporting column and base. The Add-On Workstation shares the column and base from an existing adjacent Basic Workstation.

ESD Workstations are supplied with all grounding hardware and static dissipative laminate.

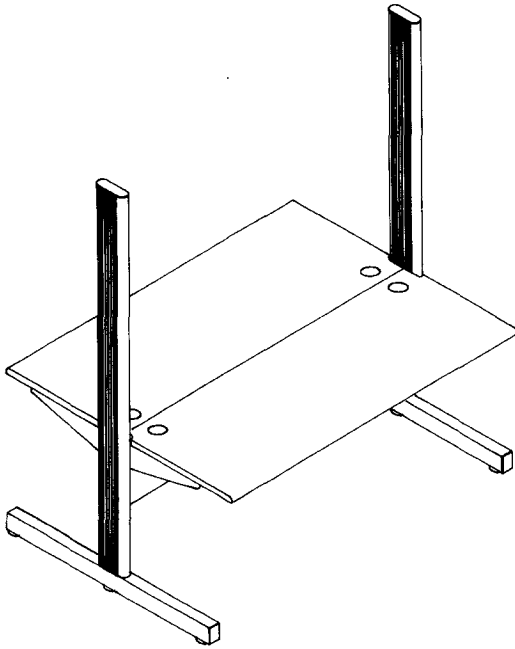

### Basic Workstations

Maximum Height	Depth	Width	Standard*	ESD*	Approx. Weight
76"	30"	48"	407334__	407384__	249
		60"	407335__	407385__	279
		72"	407336__	407386__	309

### Add-On Workstations

Maximum Height	Depth	Width	Standard*	ESD*	Approx. Weight
76"	30"	48"	407337__	407387__	206
		60"	407338__	407388__	236
		72"	407339__	407389__	266

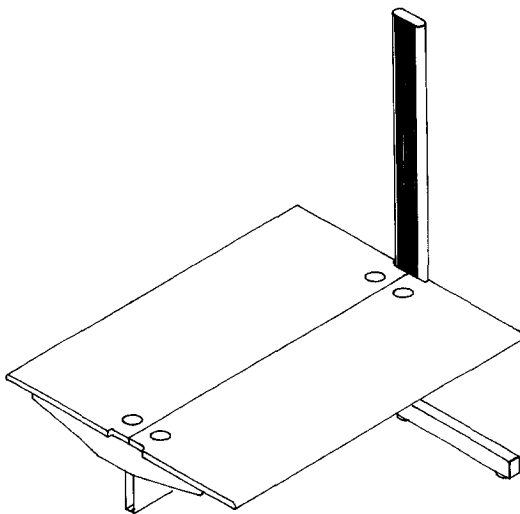

\*Specify color preference with a suffix to the product number:  
For Example, product number 407304\_\_ requires a worksurface color code **first**, and an accent color code **second**.

Worksurface Colors: A - Almond or G - Gray  
Accent Colors: A - Almond, K - Black, W - Wineberry, B - Blue or G - Gray

ESD Worksurface/Accent Colors: AA - Almond or GG - Gray



# CORNER UNITS

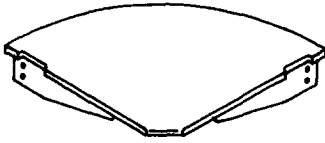

Corner Units are used to connect workstations into an "L" or "U" shape configuration. They must be used in conjunction with (2) free-standing workstations. Corner Units include a front radius edge worksurface and support brackets.

ESD Corner Units are supplied with all grounding hardware and static dissipative laminate.

## Radius Corners

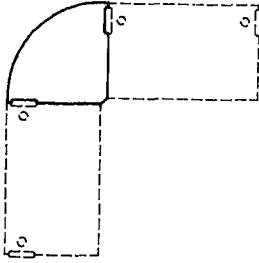

Description	Standard* Laminate	ESD* Laminate	Approx. Weight
90 Worksurface Single to Single	407030_	407030_E	40

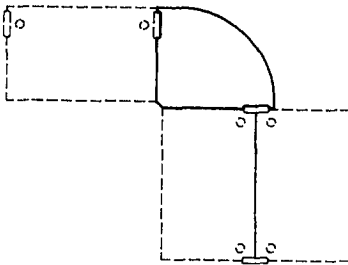

Description	Standard* Laminate	ESD* Laminate	Approx. Weight
90 Worksurface Single to Double Right	407031_	407031_E	43

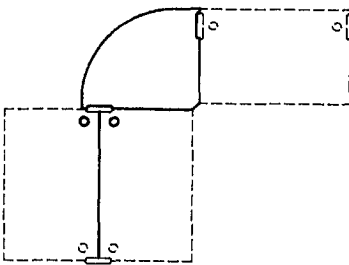

Description	Standard* Laminate	ESD* Laminate	Approx. Weight
90 Worksurface Single to Double Left	407032_	407032_E	43

\*Specify color preference with a suffix to the product number:

Worksurface Colors: A - Almond or G - Gray

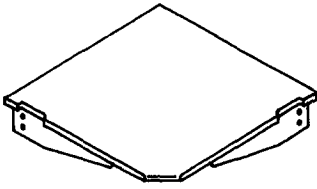

### Square Corners

Description	Standard* Laminate	ESD* Laminate	Approx. Weight
Square Worksurface Single to Single	407033_	407033_E	47

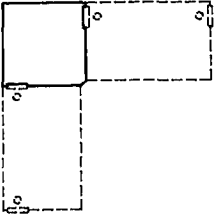

Description	Standard* Laminate	ESD* Laminate	Approx. Weight
Square Worksurface Single to Double Right	407034_	407034_E	47

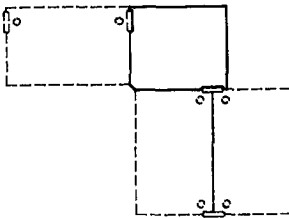

Description	Standard* Laminate	ESD* Laminate	Approx. Weight
Square Worksurface Single to Double Left	407035_	407035_E	47

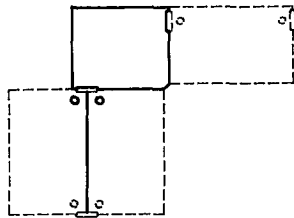

Linkage Elements are used to connect workstations into a "T" shape configuration. They include (2) front radius edge worksurfaces, (1) corner leg and support brackets

Description	Standard* Laminate	ESD* Laminate	Approx. Weight
Linkage Element	407036_	407036_E	94

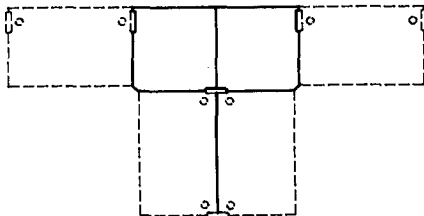

\*Specify color preference with a suffix to the product number:

Worksurface Colors: A - Almond or G - Gray

## BRIDGE UNITS

Bridge Units are used to convert empty space between workstations into usable work space. They must be used in conjunction with (2) free-standing workstations. The Basic Bridge includes a front radius edge worksurface, support brackets, apron and modesty panel.

The Double-Sided Bridge Unit includes (2) front radius edge work-surfaces, (2) double-sided worksurface support brackets, (2) aprons and (2) modesty panels.

ESD Bridge Units are supplied with all grounding hardware and static dissipative laminate.

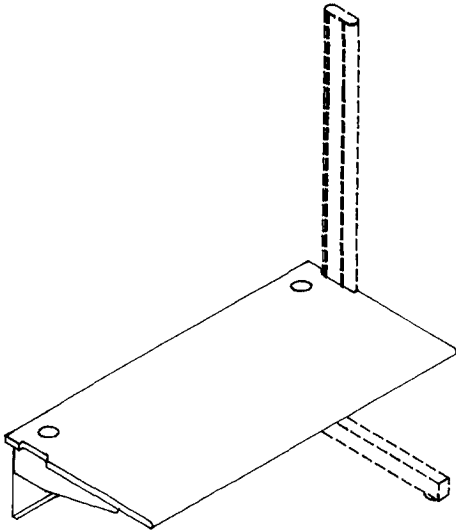

### Basic Bridge

Depth	Width	Standard* Laminate	ESD* Laminate	Approx. Weight
30"	48"	407021_	407021_E	84
	60"	407022_	407022_E	99
	72"	407023_	407023_E	114

### Double-Sided Bridge

Depth	Width	Standard* Laminate	ESD* Laminate	Approx. Weight
30"	48"	407026_	407026_E	164
	60"	407027_	407027_E	194
	72"	407028_	407028_E	224

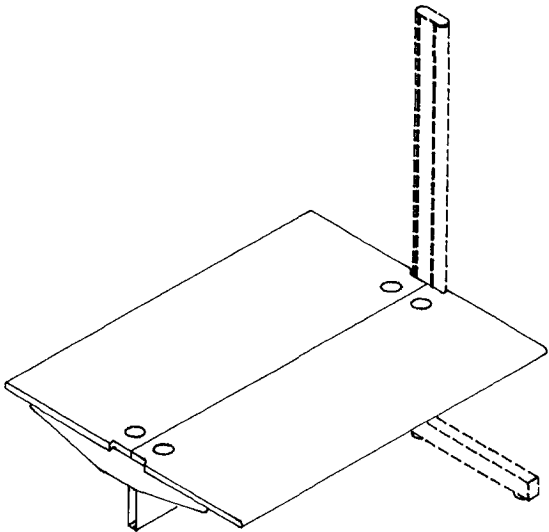

\*Specify color preference with a suffix to the product number:

Worksurface Colors: A - Almond or G - Gray

# SYSTEM SHELVING

Metal Shelves are offered with or without safety lip which runs the length of one side of the 12"D shelf and both sides of the 18"D shelf. The lip can be used for clip-on bins and various accessories.

All shelves may be mounted above or below the worksurface in a single or double-sided configuration. 12"D Shelves may be mounted at the same level and slanted in a double-sided configuration. 18"D shelves must be mounted at different levels in a double-sided configuration. Support brackets allow up/down adjustment along the column as well as tilt capabilities.

ESD Shelf Mats are available. Please refer to ESD Options.

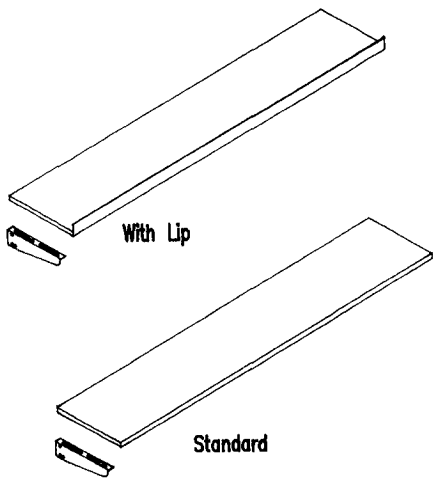

12" Deep Shelf

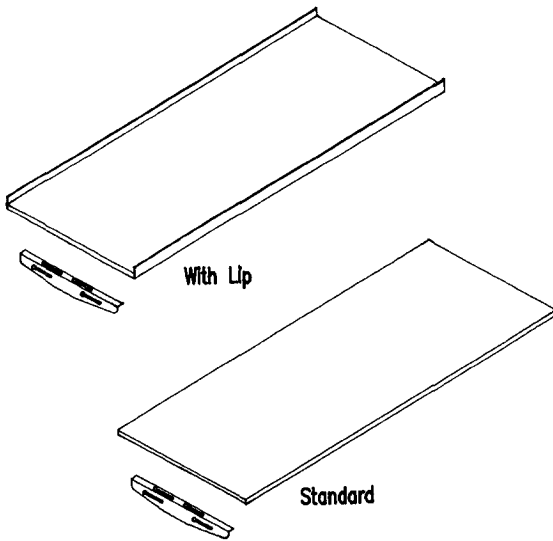

18" Deep Shelf

## System Shelving

Depth	Workstation Width	Without Lip	With Lip(s)	Approx. Weight
12"	48"	407041	407051	23
	60"	407042	407052	25
	72"	407043	407053	27
18"	48"	407046	407056	29
	60"	407047	407057	31
	72"	407048	407058	33

## SYSTEM STORAGE

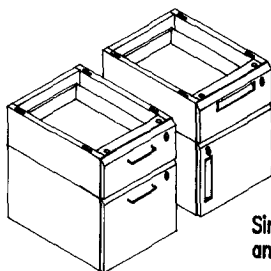
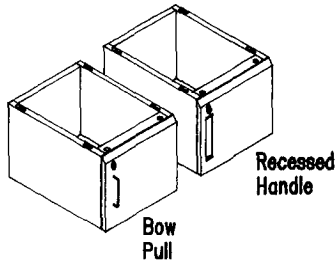
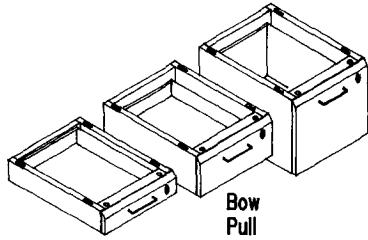
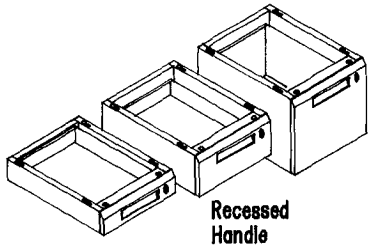

Single Box Drawer  
and Swing Door Combination

Single Box Drawer  
and File Drawer Combination

All stackable or under-worksurface mounted drawers and cabinets are made of steel and feature metal drawer fronts with recessed handle or bow pulls. Personal and Box drawers are suspended with two-member ball bearing slides, and the file drawers are suspended with three-member ball bearing slides. Threaded inserts are supplied in all worksurfaces for easy installation to either end of the workstation.

Include (1) Mounting Bracket for each hanging drawer configuration attaching directly to worksurface.

Description	Inside Dimensions		
	Depth	Width	Height
Personal Drawer	18"	12½"	1 ½"
Box Drawer	18"	12½"	4 ½"
File Drawer	18"	12½"	9 ½"
Left Door Cabinet	19 ½"	13"	11 ¾"
Right Door Cabinet	19 ½"	13"	11 ¾"

### Lockable Hanging Drawers/Cabinets

For mounting hanging drawers when lower shelf is used, maximum clearance in-between apron and lower shelf at its highest position is 12". Refer to overall height when determining hanging drawer configuration.

Description	Overall Height	Recessed Handle	Bow Pull	Approx. Weight
Personal Drawer	4"	407400	407401	8
Box Drawer	7"	407402	407403	16
File Drawer	14"	407404	407405	32
Left Door Cabinet	14"	407406	407407	19
Right Door Cabinet	14"	407408	407409	19

Description	Product Number	Approx. Weight
Mounting Bracket	407420	6

**Note:**

Please specify keying and color instructions when ordering. Drawers can be keyed alike, differently, by workstation or by area. Drawer/Cabinet front colors: Sand Tan, Gray, White and Black

## OVERHEAD STORAGE

---

Overhead Storage Units are made of steel and include a locking, internal retracting door and all necessary mounting hardware. Outside dimensions are 15"H X 15"D, with actual widths of 46", 58" and 70".

\* All dimensions are nominal

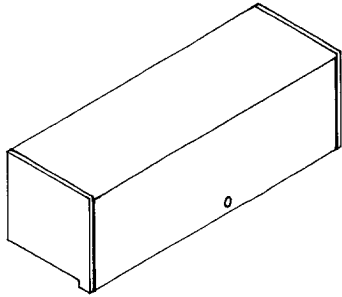

Workstation Width	Depth	Product Number	Approx. Weight
48"	15"	407501	55
60"	15"	407502	68
72"	15"	407503	83

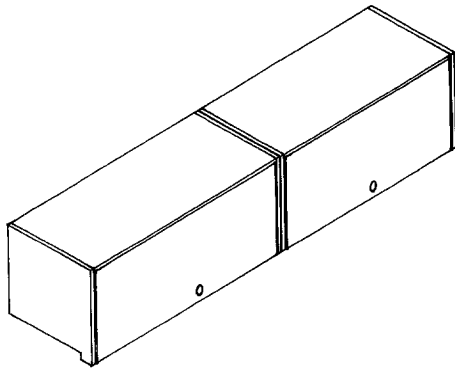
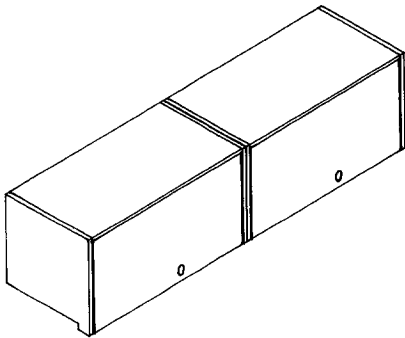

# SYSTEM ELECTRICAL

Powered Backsplashes include 15 or 20 AMP grounded receptacles and an on/off switch with built-in circuit breaker. ESD Backsplashes feature dielectric insulation. Installation guide and mounting hardware included.

Order (1) 10 ft. power cord for each powered backsplash unless a task light will be used along with backsplash. In that case, (1) column electrical harness will connect and power both.

## Standard Backsplash

Workstation		15 AMP	20 AMP	Approx. Weight
Width	Outlets			
48"	8	407131	407141	7
60"	8	407132	407142	10
72"	8	407133	407143	13

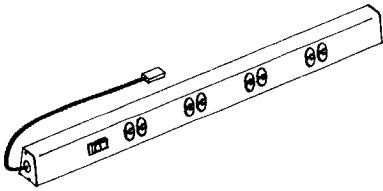

## ESD Backsplash

Workstation		15 AMP	20 AMP	Approx. Weight
Width	Outlets			
48"	8	407131E	407141E	7
60"	8	407132E	407142E	10
72"	8	407133E	407143E	13

Description	15 AMP	20 AMP	Approx. Weight
10 Foot Power Cord	407235	407236	1

Description	15 AMP	20 AMP	Approx. Weight
Column Electrical Harness	407220	407230	1

# UTILITY MANAGEMENT RACEWAY

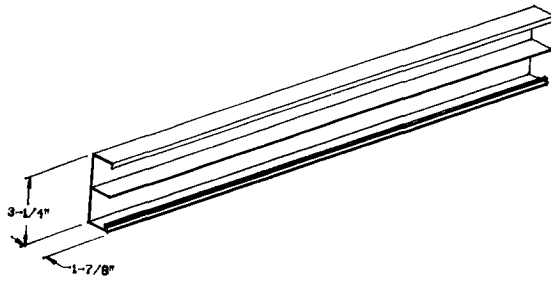

All Utility Management Raceway components are manufactured of extruded aluminum alloy and anodized for durability. Basic components include raceway body and face plate covers. The covers snap on and off to allow complete flexibility and field modification. Select raceway body width and appropriate electric/utility fittings.

Cover options selected must add up to the total width of raceway. End caps are required at the beginning and end of a raceway run.

Blank Cover

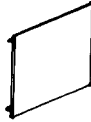

1 duplex - 15 AMP  
1 duplex - 20 AMP

## Surface Mount Raceway Body

Workstation Width	Description	Product Number	Approx. Weight
48"	Surface Mount Raceway	407151	8
60"	Surface Mount Raceway	407152	10
72"	Surface Mount Raceway	407153	12

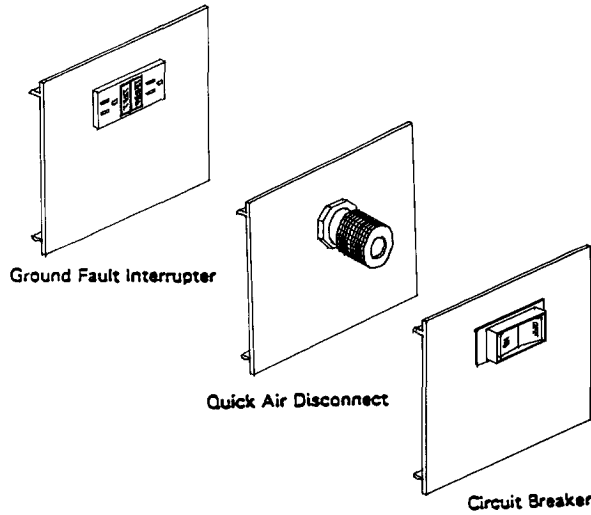

## 6" Covers

Width	Description	Product Number	Approx. Weight
6"	Blank Cover	ACCR0600	1
6"	1 duplex - 15 AMP	ACCR0615	3
6"	1 duplex - 20 AMP	ACCR0620	3
6"	Ground Fault Interrupter	ACCR06GF	3
6"	Quick Air Disconnect	ACC06QD	6
6"	Circuit Breaker	ACC06CB	2

## 12" Covers

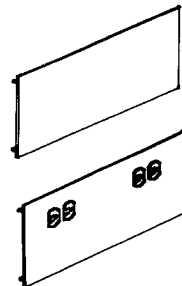

Width	Description	Product Number	Approx. Weight
12"	Blank Cover	ACCR1200	2
12"	2 duplexes - 15 AMP	ACCR1215	6
12"	2 duplexes - 20 AMP	ACCR1220	6



### 18" Covers

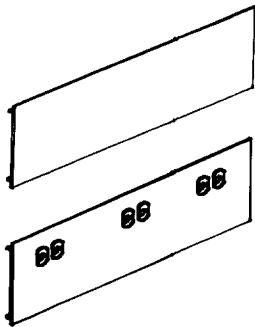

Width	Description	Product Number	Approx. Weight
18"	Blank Cover	ACCR1800	3
18"	3 duplexes - 15 AMP	ACCR1815	9
18"	3 duplexes - 20 AMP	ACCR1820	9

### 24" Covers

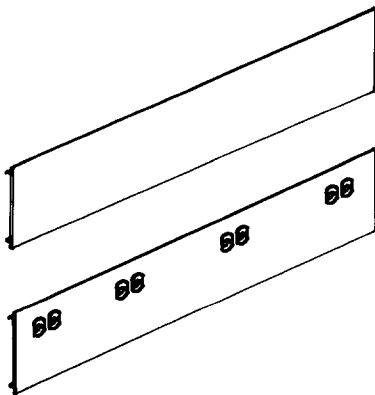

Width	Description	Product Number	Approx. Weight
24"	Blank Cover	ACCR2400	4
24"	4 duplexes - 15 AMP	ACCR2415	12
24"	4 duplexes - 20 AMP	ACCR2420	12

### 36" Covers

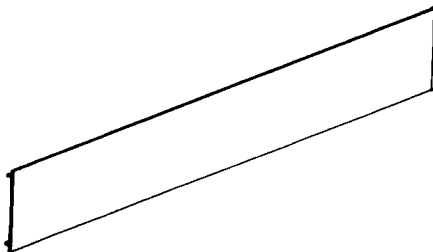

Width	Description	Product Number	Approx. Weight
36"	Blank Cover	ACCR3600	6

### End Caps



Description	Product Number	Approx. Weight
1 End Cap	ACC000EC	1

### Factory Wiring Service

Description	Product Number	Approx. Weight
Wiring Service - 15 AMP	ACCWR15	3
Wiring Service - 20 AMP	ACCWR20	3

#### Note:

Please provide cover configuration when ordering wiring service.

# SYSTEM LIGHTING

Task Lights mount in-between two columns and include an energy saving ballast and on/off switch. Hand knob allows in/out and tilt adjustment on the light fixture bracket. Diffuser offers easy removal for fluorescent tube replacement. Fluorescent tubes provided.

(1) set of supports and (1) column electrical harness must be ordered separately for each task light.

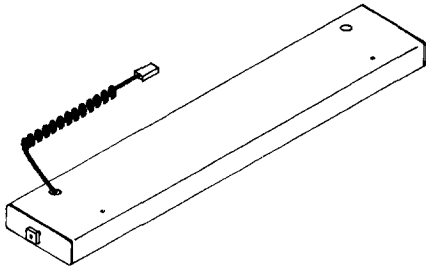

## Task Light

Workstation Width	Product Number	Approx. Weight
48"	407101	24
60"	407102	26
72"	407103	28

## Light/Tool Bar Support

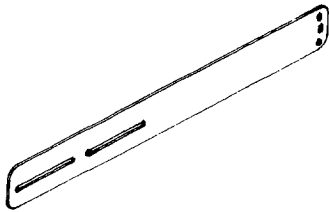

Description	Product Number	Approx. Weight
Single-Sided Supports - Set of 2	407095	3
Double-Sided Supports - Set of 2	407096	5

## Column Electrical Harness

Description	15 AMP	20 AMP	Approx. Weight
Column Electrical Harness	407220	407230	1

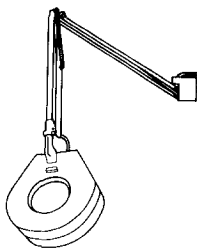

## Magnifier Light

Magnifier Lights features a 5", 3-diopter double convex precision ground lens which produces distortion-free magnification under bright fluorescent illumination. A 42" reach, steel arm with three-way adjustment is included. 6 ft. power cord provided. Include (1) Magnifier Light bracket for each Magnifier Light.

Description	Product Number	Approx. Weight
Magnifier Light	980030	9
Magnifier Light Bracket	407640	2

## MOBILE CARTS

Carts include (4) 3" swivel casters with (2) of them locking. Cart shelves are laminated with rounded corners. Top shelf may be adjusted vertically along column.

### Low Column Carts

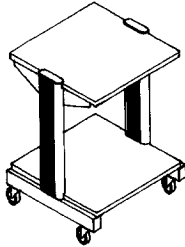

Height	Depth	Width	Standard*	ESD*	Approx. Weight
30"	18"	24"	407160__	407165__	74
30"	24"	36"	407161__	407166__	92

### Mid Column Carts

Height	Depth	Width	Standard*	ESD*	Approx. Weight
36"	18"	24"	407162__	407167__	93
36"	24"	36"	407163__	407168__	111

\*Specify color preference with a suffix to the product number:

For Example, product number 407304\_\_ requires a worksurface color code **first**, and an accent color code **second**.

Worksurface Colors: A - Almond or G - Gray

Accent Colors: A - Almond, BK - Black, W - Wineberry, B - Blue or G - Gray

ESD Worksurface/Accent: AA - Almond or GG - Gray

### Tote Carts

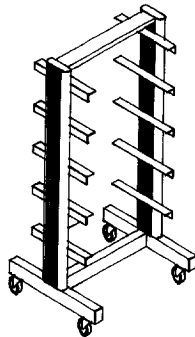

Height	Depth	Width	Product Number*	Approx. Weight
60"	18"	28"	407175_	164

### Bin Carts

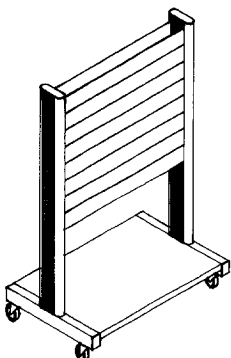

Height	Depth	Width	Product Number*	Approx. Weight
60"	18"	38"	407176_	113

\*Specify color preference with a suffix to the product number:

Accent Colors: A - Almond, BK - Black, W - Wineberry, B - Blue or G - Gray

## MOBILE PEDESTALS

Mobile Pedestals are made of steel and include a built-in cylinder lock. The pedestals are counterbalanced to protect against tilting and feature casters with a friction brake to prevent inadvertent movement. A top is included with a built-in grip for ease of movement. Inside dimensions are: Personal Drawer 1 $\frac{5}{8}$ "H, Box Drawer 4 $\frac{1}{2}$ "H, File Drawer 9 $\frac{1}{2}$ "H and Door 11 $\frac{5}{8}$ "H. Pedestals are 24"D and available in 26" or 29" heights.

\* All dimensions are nominal

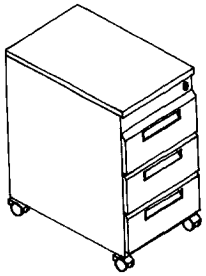

Drawer/Door Configuration	Height	Recessed Handle	Bow Pull	Approx. Weight
3 Box	26"	407430	407460	90

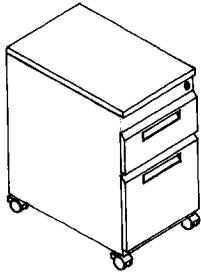

Drawer/Door Configuration	Height	Recessed Handle	Bow Pull	Approx. Weight
1 Box, 1 File	26"	407431	407461	85

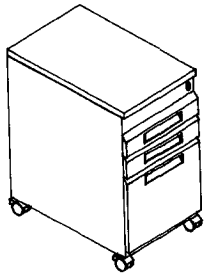

Drawer/Door Configuration	Height	Recessed Handle	Bow Pull	Approx. Weight
2 Personal, 1 File	26"	407432	407462	90

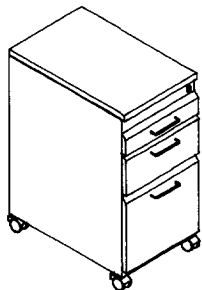

Drawer/Door Configuration	Height	Recessed Handle	Bow Pull	Approx. Weight
1 Personal, 1 Box, 1 File,	29"	407440	407470	98

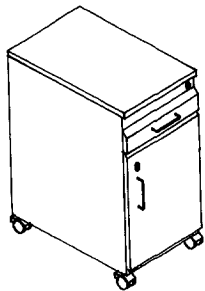

Drawer/Door Configuration	Height	Recessed Handle	Bow Pull	Approx. Weight
1 Personal, 1 Door	29"	407441	407471	88

**Note:**

Please specify keying and color instructions when ordering. Pedestals may be keyed alike, differently, by workstation or by area. Drawer/Cabinet front colors: Sand Tan, Gray, White and Black

## BIN BARS

Standard Bin Bars are painted steel. ESD Bin Bars are stainless steel with grounding kit included.

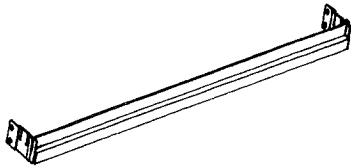

Worksurface Width	Standard		ESD	Approx. Weight
48"	407121		407126	3
60"	407122		407127	4
72"	407123		407128	5

## PARTS BINS

### Standard Parts Bins

Product* Number	Inside Dimensions			Carton Qty	Approx. Weight
	L	W	H		
ACC30210_	4 3/4"	3 1/2"	2 1/2"	24	10
ACC30220_	6 3/4"	3 1/2"	2 7/8"	24	10
ACC30230_	10 1/4"	4 3/8"	4 3/4"	12	10
ACC30240_	14"	14 3/4"	6 3/4"	6	10

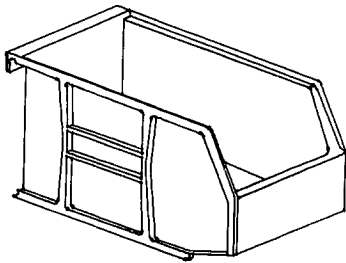

\* Specify color preference with a suffix to the product number:  
Only one color per carton may be ordered.

Standard Bin Colors: Y - Yellow, B - Blue and R - Red

### ESD Parts Bins

Product* Number	Inside Dimensions			Carton Qty	Approx. Weight
	L	W	H		
ACC4452	4"	3 1/2"	2 1/2"	1	1
ACC4453	6"	3 3/8"	2 1/2"	1	1
ACC4454	9"	4 3/8"	4 3/8"	1	1

\* ESD Bins are available in Black only.  
All dimensions are nominal

## TOOL BARS

Tool Bars are painted steel. Task Lights and Tool Bars may be mounted on one support kit.

Include (1) set of supports for each tool bar.

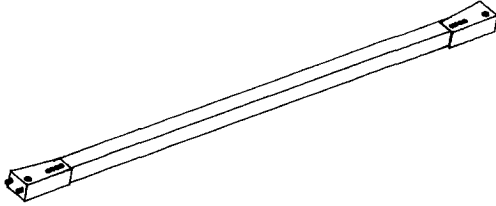

Worksurface Width	Product Number	Approx. Weight
48"	407111	4
60"	407112	5
72"	407113	6

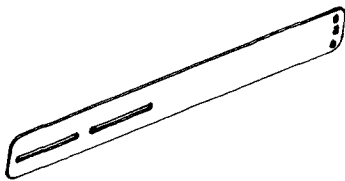

Description	Product Number	Approx. Weight
Light/Tool Bar Support Set	407095	3

### Tool Bar Trolley

Tool Bar Trolleys include an eye bolt to accept a variety of tool balancers.



Description	Product Number	Approx. Weight
Tool Bar Trolley	407115	1

## FOOTRAILS

Footrails are painted steel tube and feature height and depth adjustment.

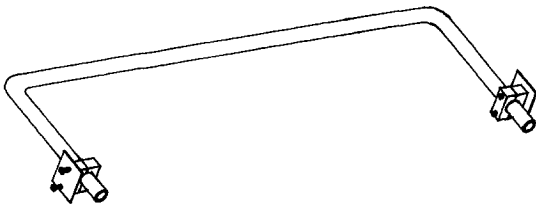

Description	Product Number	Approx. Weight
48"W Footrail	407081	10
60"W Footrail	407082	15
72"W Footrail	407083	20

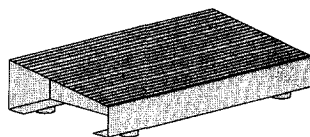

Portable Footrest	FT-10007-01	11
-------------------	-------------	----

## TACK PANELS

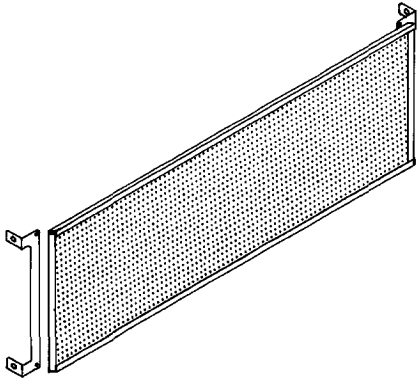

12"H Tack Panels are mounted in-between columns. Fabric is color-coordinated with accent strip. Support bracket included.

Worksurface Width	Product Number*	Approx. Weight
48"	407181_	18
60"	407182_	22
72"	407183_	26

\* Specify color preference with a suffix to the product number:

Accent Colors: A - Almond, BK - Black, W - Wineberry, B - Blue or G - Gray

## COLUMNS/BASES

ESD Columns are supplied with grounding kit.

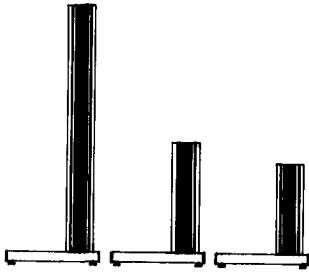

### Basic Column Kits with Bases

Maximum Workstation Height	Standard*	ESD*	Approx. Weight
30"H Low Column	407011_	407001_E	20
36"H Mid Column	407012_	407002_E	22
76"H High Column	407010_	407000_E	36

### Double-Sided Column Kits with Bases

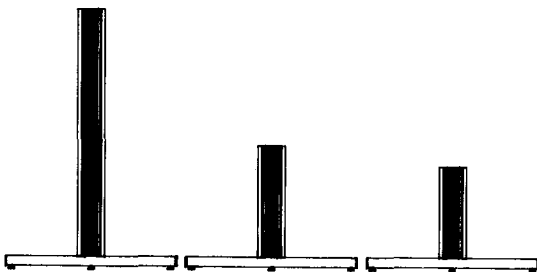

Maximum Workstation Height	Standard*	ESD*	Approx. Weight
30"H Low Column	407016_	407006_E	29
36"H Mid Column	407017_	407007_E	31
76"H High Column	407015_	407005_E	45

Specify color preference with a suffix to the product number:

Accent Colors: A - Almond, BK - Black, W - Wineberry, B - Blue or G - Gray  
ESD Accent Colors: A - Almond or G - Gray

# ACCESSORIES

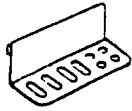

Description	Product Number	Weight
Tool Holder	407260	1

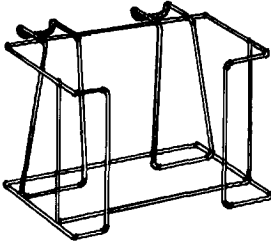

Description	Product Number	Weight
Kimwipe Holder	ACC7001	1

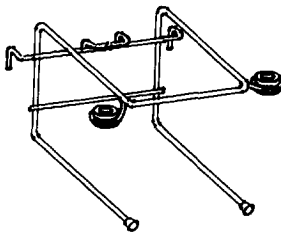

Description	Product Number	Weight
Dual Solder Spool	ACC7002	1

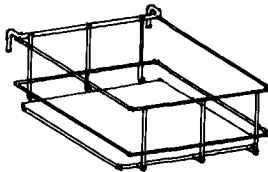

Description	Product Number	Weight
Bottle Holder	ACC7004	1

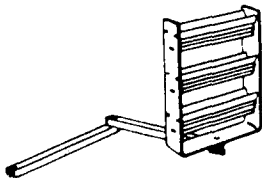

Description	Product Number	Weight
Articulating Bin Rack	407625	11

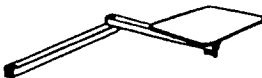

Description	Product Number	Weight
Articulating Solder Station	407630	8



Description	Product Number	Weight
Articulating Monitor Platform	407635	10

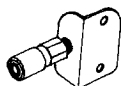

Description	Product Number	Weight
Quick Air Disconnect	407090	1



## ESD OPTIONS

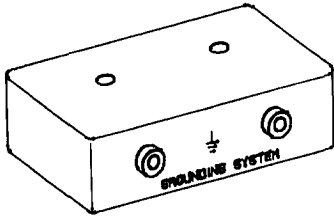

The Wrist Strap Grounding System provides grounding of two wrist straps using a common point to ground. It measures 3" X 1 1/2" and mounts easily on the bench. (2) built-in banana jacks and 10 ft. grounding cord are included.

Description	Product Number	Weight
Wrist Strap Grounding Kit	990519	1

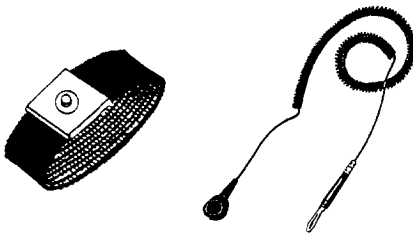

The wrist strap ensures all-around skin contact and electrical conductivity. 5 ft. coiled cord included.

Description	Product Number	Weight
Wrist Strap	990517	1

For use with Bin Bars and Shelves.

Description	Product Number	Weight
Accessory Grounding Kit	407200	1

Description	Product Number	Weight
Drawer/Cabinet Grounding Kit	407201	1

### ESD Shelf Mats

ESD Shelf Mats are used when a static dissipative surface on a shelf is desired. All necessary grounding hardware included.

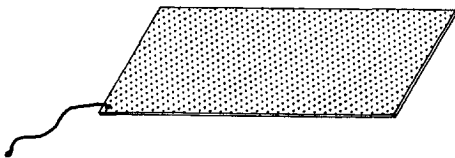

Depth	Width	Standard*	Approx. Weight
12"	48"	407206_	2
	60"	407207_	2
	72"	407208_	2
18"	48"	407211_	2
	60"	407212_	2
	72"	407213_	2

\*Specify color preference with a suffix to the product number:

ESD Shelf Mat Colors: A - Almond or G - Gray

## **GENERAL ORDERING INFORMATION**

---

### **Pricing, Terms, and Conditions**

Net 30 days with established credit.

All prices are F.O.B. Factory and are subject to change without notice. Due to our continual research and development, changes may occur in product specifications. We reserve the right at any time to alter design and to substitute materials and parts to supply the article which is our standard at time of shipment.

Remit all payments to Kewaunee Scientific Corporation, Technical Products Group, P.O. Box 60220, Charlotte, NC 28260. No state or local sales tax, or any other tax that may be levied or assessed upon a sale or purchase of products listed in this ordering guide is included in prices quoted. Any such taxes must be paid by the purchaser, and if, by law, the vendor is chargeable with the collection or payment thereof, the sum must be added as tax to the prices quoted.

### **Order Confirmation**

All orders are acknowledged upon receipt, it is the customer's responsibility to see that the items shown conform to those ordered, and if any discrepancy exists, to notify a Kewaunee Scientific representative immediately. The order acknowledgement is the final agreement between the customer and Kewaunee Scientific Corporation and supersedes all prior documents and may not be modified except by a revised purchase order.

### **Shipping**

All shipments are made "best way" (motor freight, common carrier, UPS) unless otherwise requested in writing. Kewaunee is not responsible for delay in shipment caused by conditions beyond our control. All weights shown are approximate and obtained from standard packaging procedures.

### **Damage in Transit**

Customer should inspect shipment upon receipt. All loss or damage claims must be made against the carrier. No claims for damage may be deducted from invoices.

### **Returns**

Returned merchandise will not be accepted unless first authorized by Kewaunee Scientific Corporation. A 20% restocking charge, plus repair and rehabilitation, and any freight charges incurred will be applied to any return shipment. The customer will be billed for any damaged goods not collectible from the carrier. Return shipments must be prepaid and returned via same delivering carrier(s).

### **Colors**

Standard paint colors for EVOLUTION Technical Workstations are Sand Tan, Dove Gray, Flint Gray, Metallic Gray, Ice Blue, Fashion Blue, Navy, Burgundy, Mocha, Black and White. Customized colors are available upon request.

### **Assembly**

Some assembly is required. Instruction manuals will accompany all orders.

### **Specifications**

A complete set of product specifications is available upon request. All dimensions listed are nominal.

### **Special Product Requests**

If quantities or circumstance warrant, we will be pleased to quote pricing on custom products. Send details, drawings and specifications Attn: Kewaunee Customer Service Department. Lead time will normally increase and custom orders are noncancellable.

### **How to Order**

Purchase orders are to be made to Kewaunee Scientific Corporation, Technical Products Group. The mailing address is as follows:

### **Kewaunee Scientific Corporation**

2700 West Front Street  
Statesville, NC 28677-2927

P.O. Box 1842  
Statesville, NC 28687-1842

**CALL TOLL FREE 800/824/6626**

---



Kewaunee Scientific Corporation  
2700 West Front Street  
Statesville, NC 28677-2927

P.O. Box 1842  
Statesville, NC 28687-1842  
Telephone: 704-873-7202