

Evolution[®]

Column Based Workstation



KEWAUNEE[®]

encouraging new discovery...*Worldwide*

EVOLUTION



Column Based Workstations

- Infinitely height adjustable worksurfaces and shelving
- Starter and add-on assemblies; single and double-sided
- Laminates, edge-grain maple, phenolic resin and Kemresin worksurfaces available
- UL listed, column mount power bars with power switch and built-in circuit breaker
- Power, data, and service fixtures mountable in columns with pre-wired and pre-piped options
- Storage options include mobile, suspended, freestanding, and overhead
- Meets SEFA 10, Adaptable Casework Systems, Class 7 (freestanding) and Class 8 (mobile) standards



Contents

Evolution Workstations	2
9" Column Modules.....	6
12" Column Modules.....	10
Work Tops	14
Corner Module	16
Columns	18
Shelving	19
Mobile Floor Shelving.....	25
Lighting.....	26
Power Bar	27
Privacy Panels.....	28
Bin Bar.....	29
Horizontal Chase	30
Service Fittings	31
Mobile Base Cabinets	40
Suspended Base Cabinets	46
Upper Storage Cabinets	52
Ceiling Service Panels.....	64
Technical Information.....	68
Index.....	76

Kewaunee's Evolution is a free standing workstation system that is designed to meet the changing needs of today's Laboratory and Technical environments. The column based design offers infinite height adjustment of the worksurface and shelving; as well as other column mounted accessories. Its modular design and ability to share columns helps control cost and simplifies lab layout. Three standard column heights create platforms with and without an above counter support structure. Evolution is available pre-piped and pre-wired and easily incorporates with overhead utility grids or service carriers and panels. Evolution is designed for mobile, suspended, free-standing, and overhead storage.

Evolution Workstation Part Numbers

Workstation Part Number Explanation

FV 11 M 84 24 36 - P, G

<p>System Type</p> <p>FV = Evolution</p> <p>Column Type</p> <p>10 = Single-sided Starter 9" Column 11 = Single-sided Add-on 9" Column 20 = Double-sided Starter 9" Column 21 = Double-sided Add-on 9" Column 30 = Single-sided Starter 12" Column 31 = Single-sided Add-on 12" Column 40 = Double-sided Starter 12" Column 41 = Double-sided Add-on 12" Column</p> <p>Material</p> <p>M = Metal (powder coated steel & aluminum) P = Plastic Laminate E = ESD Plastic Laminate R = Kemresin T = Phenolic Resin</p>	<p style="text-align: center;">Work Top Length</p> <p>Standard Lengths: 24" - 30" - 36" - 42" - 48" 54" - 60" - 66" - 72" - 78" - 84" - 90" - 96"</p> <p style="text-align: center;">Work Top Depth</p> <p>Standard Depths: 24" - 30" - 36" Double-sided workstations use two work tops back-to-back Double-sided Overall Depth = Standard Depth x 2</p>	<p style="text-align: center;">Options (see below)</p> <p style="text-align: center;">Separator</p> <p style="text-align: center;">Column Height</p> <p>Standard Heights: 36" - 54" - 84"</p>
--------------------------------------------------------------------------------------------------------------------------------------------------------------------------------------------------------------------------------------------------------------------------------------------------------------------------------------------------------------------------------------------------------------------------------------------------------------------------------------------------------------------------------------------------------------------------------------------------------------------------------------------------------------------------------------------	---------------------------------------------------------------------------------------------------------------------------------------------------------------------------------------------------------------------------------------------------------------------------------------------------------------------------------------------------------------------------------------------------------------	--------------------------------------------------------------------------------------------------------------------------------------------------------------------------------------------------------------------

} **Work Top Materials**

Workstation Options

FV 11 M 84 24 36 - P, G

<p>Accent Strip Options</p> <p>P = Plastic Laminate Accent Strip M = Powder Coated Steel Accent Strip</p>	<p>Column Foot Options</p> <p>G = 1½" Diameter Leveling Glide C = 4" Swivel Locking Caster H = 4" Heavy Duty Leveling Caster</p>
-------------------------------------------------------------------------------------------------------------------------------	-------------------------------------------------------------------------------------------------------------------------------------------------------------------

Load Ratings — Assembly Load Maximums

Single-sided – 9" Column Workstation

Workstation on Glides or Heavy Duty Leveling Casters: 1,200lbs	Workstation on Swivel Casters: 800lbs
Worksurface Frame: 750lbs (includes worksurface and suspended storage)	Shelving: (each) 250lbs

Double-sided – 9" Column Workstation

Workstation on Glides or Heavy Duty Leveling Casters: 2,000lbs	Workstation on Swivel Casters: .. 1200lbs
Worksurface Frame:(each side)..... 500lbs (includes worksurface and suspended storage)	Shelving: (each) 250lbs

Single-sided – 12" Column Workstation

Workstation on Glides or Heavy Duty Leveling Casters: 1,750lbs	Workstation on Swivel Casters: 800lbs
Worksurface Frame: 1000lbs (includes worksurface and suspended storage)	Shelving: (each) 250lbs

Double-sided – 12" Column Workstation

Workstation on Glides or Heavy Duty Leveling Casters: 2,500lbs	Workstation on Swivel Casters: .. 1200lbs
Worksurface Frame:(each side)..... 600lbs (includes worksurface and suspended storage)	Shelving: (each) 250lbs

Typical Evolution Workstation

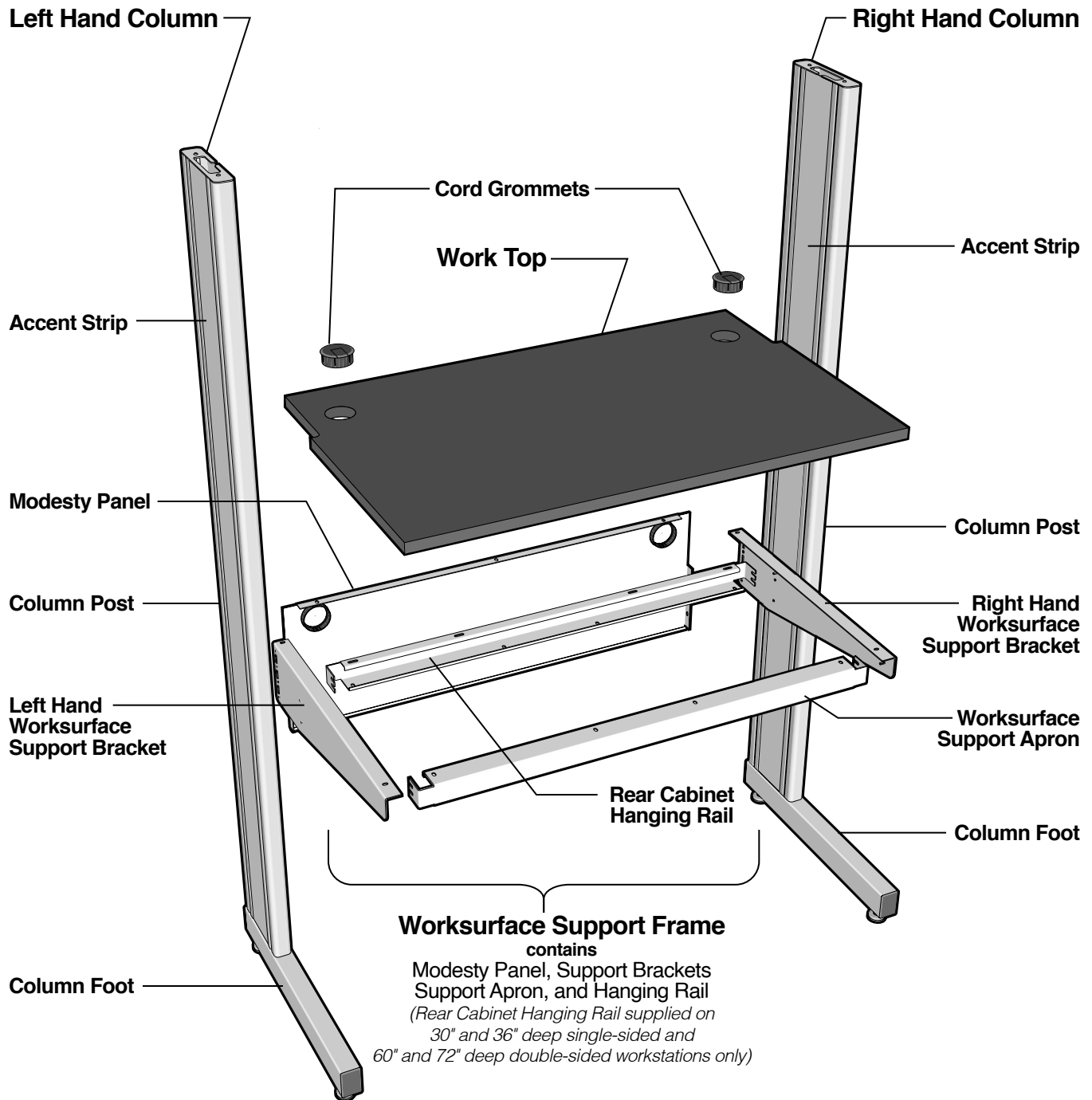

Evolution Work Top Material Options

Kemresin®

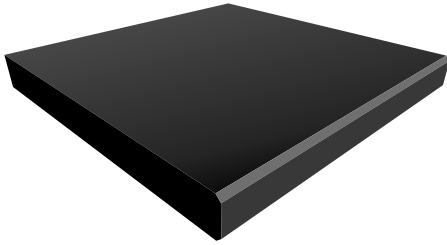

Edge Treatment:
Chamfered front edge, finished square ends and back.

Appearance: Ultra-smooth non-porous surface.

Standard Colors: Black, Grey, Putty, Slate

Composition: 1" thick molded epoxy resin.

Physical Properties: Excellent resistance to practically all acids, alkalies and solvents. Highly resistant to heat and normal physical abuse.

Applications: Use wherever optimum physical and chemical resisting properties are required.

Phenolic Resin

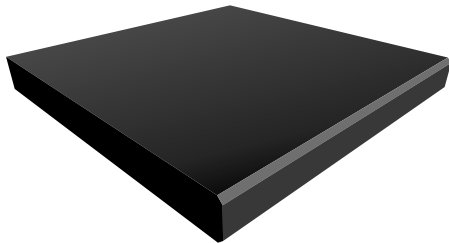

Edge Treatment:
Chamfered front edge, finished square ends and back.

Appearance: Hard, smooth, non-glare surface

Standard Colors: Black
Other colors available on request.

Composition: Cellulose fiber reinforced phenolic resin core with a polyurethane copolymer surface.

Physical Properties: Good chemical resistance to wide range of acids, alkalies and solvents.

Applications: Use wherever a high degree of chemical resistance is required.

Evolution Column Options

Column Accent Strip Options

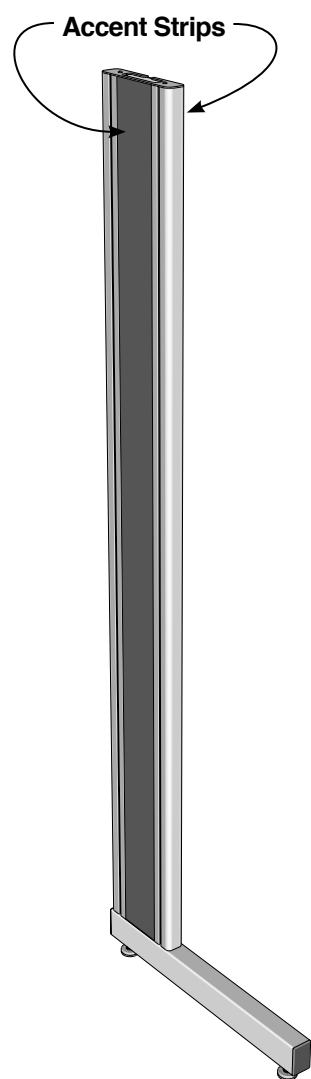

Workstation Support Columns are furnished with two accent strips, one on each side of the column. Accent strips may be either Plastic Laminate or Powder Coated Steel in colors to either match or accent the Workstation color.

Plastic Laminate Accent Strip

May be used on any 9" or 12" column.

- Standard Colors:** Almond Dove Gray
 Black Light Neutral
 Brittany Blue
Other colors available on request.

Powder Coated Steel Accent Strip

Required for columns with fittings or fixtures.

- Standard Colors:** *All Standard Kewaunee Steel Finish Colors*

Column Foot Options

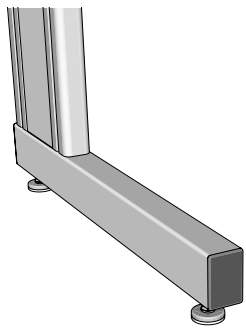

1 1/2" Diameter Glide
 Overall Height: 1"
 Load Rating: 500lbs each

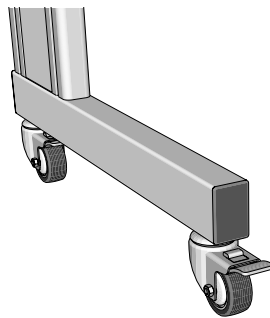

Swivel Locking Caster
 Overall Height: 4"
 Load Rating: 200lbs each

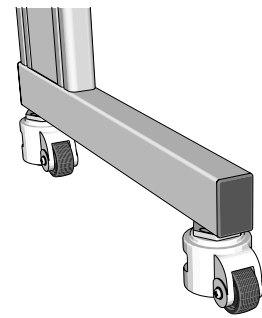

Heavy Duty Leveling Caster
 Overall Height: 4"
 Load Rating: 500lbs each

Single-sided – 9" Column Modules

Single-sided 9" Column Modules are available in three heights; 36", 54", and 84", three depths; 24", 30" and 36", and in lengths as shown — in both starter assemblies and add-on assemblies. Starter assemblies consist of two columns, a worksurface support frame, and all required

hardware. Add-on assemblies consist of one column, a worksurface support frame, and all required hardware. Workstation modules ship knocked-down for assembly in the field.

Work Tops must be specified separately. (see page 16)

36" High – 24" Deep

Starter	Add-on
FV10M362424- 24"L	FV11M362424- 24"L
FV10M362430- 30"L	FV11M362430- 30"L
FV10M362436- 36"L	FV11M362436- 36"L
FV10M362442- 42"L	FV11M362442- 42"L
FV10M362448- 48"L	FV11M362448- 48"L
FV10M362454- 54"L	FV11M362454- 54"L
FV10M362460- 60"L	FV11M362460- 60"L
FV10M362466- 66"L	FV11M362466- 66"L
FV10M362472- 72"L	FV11M362472- 72"L
FV10M362478- 78"L	FV11M362478- 78"L
FV10M362484- 84"L	FV11M362484- 84"L
FV10M362490- 90"L	FV11M362490- 90"L
FV10M362496- 96"L	FV11M362496- 96"L

36" High – 30" Deep

Starter	Add-on
FV10M363024- 24"L	FV11M363024- 24"L
FV10M363030- 30"L	FV11M363030- 30"L
FV10M363036- 36"L	FV11M363036- 36"L
FV10M363042- 42"L	FV11M363042- 42"L
FV10M363048- 48"L	FV11M363048- 48"L
FV10M363054- 54"L	FV11M363054- 54"L
FV10M363060- 60"L	FV11M363060- 60"L
FV10M363066- 66"L	FV11M363066- 66"L
FV10M363072- 72"L	FV11M363072- 72"L
FV10M363078- 78"L	FV11M363078- 78"L
FV10M363084- 84"L	FV11M363084- 84"L
FV10M363090- 90"L	FV11M363090- 90"L
FV10M363096- 96"L	FV11M363096- 96"L

54" High – 24" Deep

Starter	Add-on
FV10M542424- 24"L	FV11M542424- 24"L
FV10M542430- 30"L	FV11M542430- 30"L
FV10M542436- 36"L	FV11M542436- 36"L
FV10M542442- 42"L	FV11M542442- 42"L
FV10M542448- 48"L	FV11M542448- 48"L
FV10M542454- 54"L	FV11M542454- 54"L
FV10M542460- 60"L	FV11M542460- 60"L
FV10M542466- 66"L	FV11M542466- 66"L
FV10M542472- 72"L	FV11M542472- 72"L
FV10M542478- 78"L	FV11M542478- 78"L
FV10M542484- 84"L	FV11M542484- 84"L
FV10M542490- 90"L	FV11M542490- 90"L
FV10M542496- 96"L	FV11M542496- 96"L

54" High – 30" Deep

Starter	Add-on
FV10M543024- 24"L	FV11M543024- 24"L
FV10M543030- 30"L	FV11M543030- 30"L
FV10M543036- 36"L	FV11M543036- 36"L
FV10M543042- 42"L	FV11M543042- 42"L
FV10M543048- 48"L	FV11M543048- 48"L
FV10M543054- 54"L	FV11M543054- 54"L
FV10M543060- 60"L	FV11M543060- 60"L
FV10M543066- 66"L	FV11M543066- 66"L
FV10M543072- 72"L	FV11M543072- 72"L
FV10M543078- 78"L	FV11M543078- 78"L
FV10M543084- 84"L	FV11M543084- 84"L
FV10M543090- 90"L	FV11M543090- 90"L
FV10M543096- 96"L	FV11M543096- 96"L

84" High – 24" Deep

Starter	Add-on
FV10M842424- 24"L	FV11M842424- 24"L
FV10M842430- 30"L	FV11M842430- 30"L
FV10M842436- 36"L	FV11M842436- 36"L
FV10M842442- 42"L	FV11M842442- 42"L
FV10M842448- 48"L	FV11M842448- 48"L
FV10M842454- 54"L	FV11M842454- 54"L
FV10M842460- 60"L	FV11M842460- 60"L
FV10M842466- 66"L	FV11M842466- 66"L
FV10M842472- 72"L	FV11M842472- 72"L
FV10M842478- 78"L	FV11M842478- 78"L
FV10M842484- 84"L	FV11M842484- 84"L
FV10M842490- 90"L	FV11M842490- 90"L
FV10M842496- 96"L	FV11M842496- 96"L

84" High – 30" Deep

Starter	Add-on
FV10M843024- 24"L	FV11M843024- 24"L
FV10M843030- 30"L	FV11M843030- 30"L
FV10M843036- 36"L	FV11M843036- 36"L
FV10M843042- 42"L	FV11M843042- 42"L
FV10M843048- 48"L	FV11M843048- 48"L
FV10M843054- 54"L	FV11M843054- 54"L
FV10M843060- 60"L	FV11M843060- 60"L
FV10M843066- 66"L	FV11M843066- 66"L
FV10M843072- 72"L	FV11M843072- 72"L
FV10M843078- 78"L	FV11M843078- 78"L
FV10M843084- 84"L	FV11M843084- 84"L
FV10M843090- 90"L	FV11M843090- 90"L
FV10M843096- 96"L	FV11M843096- 96"L

Single-sided – 9" Column Modules

Module Options:

The two final digits in the part numbers specifies the Accent Strip Material option and the Column Foot option for the workstation.

Accent Strip Material Options:

P = Plastic Laminate Panel
M = Powder Coated Steel Panel

Column Foot Options:

G = 1 1/2" Leveling Glide
C = 4" Swivel Locking Caster
H = 4" Heavy Duty Leveling Caster

Example: FV10M362424-P,G = with Laminate Accent Strip and Glides

36" High – 36" Deep

36" High

Starter

FV10M363624-	24"L
FV10M363630-	30"L
FV10M363636-	36"L
FV10M363642-	42"L
FV10M363648-	48"L
FV10M363654-	54"L
FV10M363660-	60"L
FV10M363666-	66"L
FV10M363672-	72"L
FV10M363678-	78"L
FV10M363684-	84"L
FV10M363690-	90"L
FV10M363696-	96"L

Add-on

FV11M363624-	24"L
FV11M363630-	30"L
FV11M363636-	36"L
FV11M363642-	42"L
FV11M363648-	48"L
FV11M363654-	54"L
FV11M363660-	60"L
FV11M363666-	66"L
FV11M363672-	72"L
FV11M363678-	78"L
FV11M363684-	84"L
FV11M363690-	90"L
FV11M363696-	96"L

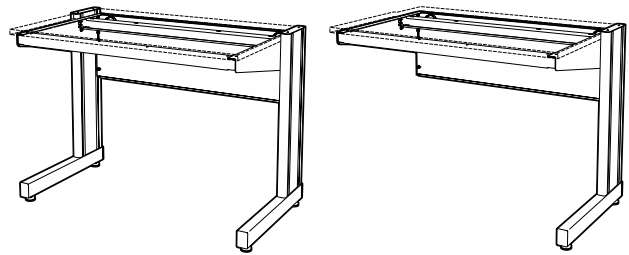

54" High – 36" Deep

54" High

Starter

FV10M543624-	24"L
FV10M543630-	30"L
FV10M543636-	36"L
FV10M543642-	42"L
FV10M543648-	48"L
FV10M543654-	54"L
FV10M543660-	60"L
FV10M543666-	66"L
FV10M543672-	72"L
FV10M543678-	78"L
FV10M543684-	84"L
FV10M543690-	90"L
FV10M543696-	96"L

Add-on

FV11M543624-	24"L
FV11M543630-	30"L
FV11M543636-	36"L
FV11M543642-	42"L
FV11M543648-	48"L
FV11M543654-	54"L
FV11M543660-	60"L
FV11M543666-	66"L
FV11M543672-	72"L
FV11M543678-	78"L
FV11M543684-	84"L
FV11M543690-	90"L
FV11M543696-	96"L

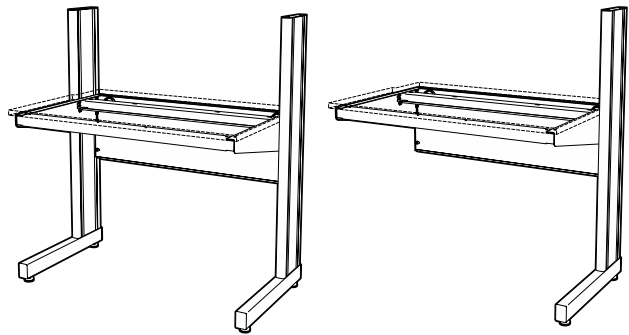

84" High – 36" Deep

84" High

Starter

FV10M843624-	24"L
FV10M843630-	30"L
FV10M843636-	36"L
FV10M843642-	42"L
FV10M843648-	48"L
FV10M843654-	54"L
FV10M843660-	60"L
FV10M843666-	66"L
FV10M843672-	72"L
FV10M843678-	78"L
FV10M843684-	84"L
FV10M843690-	90"L
FV10M843696-	96"L

Add-on

FV11M843624-	24"L
FV11M843630-	30"L
FV11M843636-	36"L
FV11M843642-	42"L
FV11M843648-	48"L
FV11M843654-	54"L
FV11M843660-	60"L
FV11M843666-	66"L
FV11M843672-	72"L
FV11M843678-	78"L
FV11M843684-	84"L
FV11M843690-	90"L
FV11M843696-	96"L

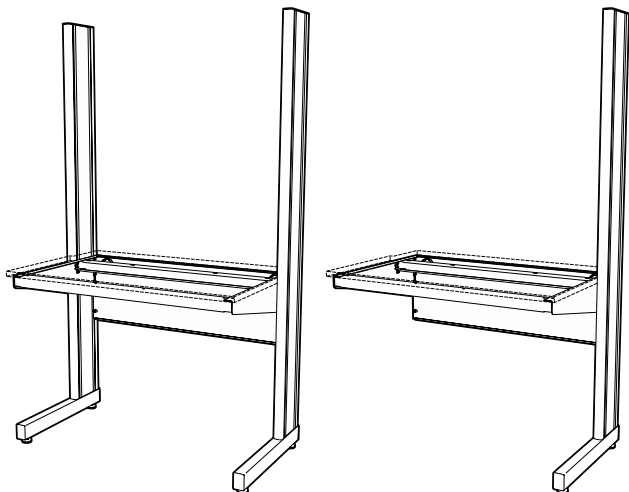

Double-sided – 9" Column Modules

Double-sided 9" Column Modules are available in three heights; 36", 54", and 84", three depths; 48", 60" and 72", and in lengths as shown — in both starter assemblies and add-on assemblies. Starter assemblies consist of two columns, two worksurface support frames, and all

required hardware. Add-on assemblies consist of one column, two worksurface support frames, and all required hardware. Workstation modules ship knocked-down for assembly in the field.

Work Tops must be specified separately. (see page 16)

36" High – 48" Deep

Starter	Add-on
FV20M364824-... 24"L	FV21M364824-... 24"L
FV20M364830-... 30"L	FV21M364830-... 30"L
FV20M364836-... 36"L	FV21M364836-... 36"L
FV20M364842-... 42"L	FV21M364842-... 42"L
FV20M364848-... 48"L	FV21M364848-... 48"L
FV20M364854-... 54"L	FV21M364854-... 54"L
FV20M364860-... 60"L	FV21M364860-... 60"L
FV20M364866-... 66"L	FV21M364866-... 66"L
FV20M364872-... 72"L	FV21M364872-... 72"L
FV20M364878-... 78"L	FV21M364878-... 78"L
FV20M364884-... 84"L	FV21M364884-... 84"L
FV20M364890-... 90"L	FV21M364890-... 90"L
FV20M364896-... 96"L	FV21M364896-... 96"L

36" High – 60" Deep

Starter	Add-on
FV20M366024-... 24"L	FV21M366024-... 24"L
FV20M366030-... 30"L	FV21M366030-... 30"L
FV20M366036-... 36"L	FV21M366036-... 36"L
FV20M366042-... 42"L	FV21M366042-... 42"L
FV20M366048-... 48"L	FV21M366048-... 48"L
FV20M366054-... 54"L	FV21M366054-... 54"L
FV20M366060-... 60"L	FV21M366060-... 60"L
FV20M366066-... 66"L	FV21M366066-... 66"L
FV20M366072-... 72"L	FV21M366072-... 72"L
FV20M366078-... 78"L	FV21M366078-... 78"L
FV20M366084-... 84"L	FV21M366084-... 84"L
FV20M366090-... 90"L	FV21M366090-... 90"L
FV20M366096-... 96"L	FV21M366096-... 96"L

54" High – 48" Deep

Starter	Add-on
FV20M544824-... 24"L	FV21M544824-... 24"L
FV20M544830-... 30"L	FV21M544830-... 30"L
FV20M544836-... 36"L	FV21M544836-... 36"L
FV20M544842-... 42"L	FV21M544842-... 42"L
FV20M544848-... 48"L	FV21M544848-... 48"L
FV20M544854-... 54"L	FV21M544854-... 54"L
FV20M544860-... 60"L	FV21M544860-... 60"L
FV20M544866-... 66"L	FV21M544866-... 66"L
FV20M544872-... 72"L	FV21M544872-... 72"L
FV20M544878-... 78"L	FV21M544878-... 78"L
FV20M544884-... 84"L	FV21M544884-... 84"L
FV20M544890-... 90"L	FV21M544890-... 90"L
FV20M544896-... 96"L	FV21M544896-... 96"L

54" High – 60" Deep

Starter	Add-on
FV20M546024-... 24"L	FV21M546024-... 24"L
FV20M546030-... 30"L	FV21M546030-... 30"L
FV20M546036-... 36"L	FV21M546036-... 36"L
FV20M546042-... 42"L	FV21M546042-... 42"L
FV20M546048-... 48"L	FV21M546048-... 48"L
FV20M546054-... 54"L	FV21M546054-... 54"L
FV20M546060-... 60"L	FV21M546060-... 60"L
FV20M546066-... 66"L	FV21M546066-... 66"L
FV20M546072-... 72"L	FV21M546072-... 72"L
FV20M546078-... 78"L	FV21M546078-... 78"L
FV20M546084-... 84"L	FV21M546084-... 84"L
FV20M546090-... 90"L	FV21M546090-... 90"L
FV20M546096-... 96"L	FV21M546096-... 96"L

84" High – 48" Deep

Starter	Add-on
FV20M844824-... 24"L	FV21M844824-... 24"L
FV20M844830-... 30"L	FV21M844830-... 30"L
FV20M844836-... 36"L	FV21M844836-... 36"L
FV20M844842-... 42"L	FV21M844842-... 42"L
FV20M844848-... 48"L	FV21M844848-... 48"L
FV20M844854-... 54"L	FV21M844854-... 54"L
FV20M844860-... 60"L	FV21M844860-... 60"L
FV20M844866-... 66"L	FV21M844866-... 66"L
FV20M844872-... 72"L	FV21M844872-... 72"L
FV20M844878-... 78"L	FV21M844878-... 78"L
FV20M844884-... 84"L	FV21M844884-... 84"L
FV20M844890-... 90"L	FV21M844890-... 90"L
FV20M844896-... 96"L	FV21M844896-... 96"L

84" High – 60" Deep

Starter	Add-on
FV20M846024-... 24"L	FV21M846024-... 24"L
FV20M846030-... 30"L	FV21M846030-... 30"L
FV20M846036-... 36"L	FV21M846036-... 36"L
FV20M846042-... 42"L	FV21M846042-... 42"L
FV20M846048-... 48"L	FV21M846048-... 48"L
FV20M846054-... 54"L	FV21M846054-... 54"L
FV20M846060-... 60"L	FV21M846060-... 60"L
FV20M846066-... 66"L	FV21M846066-... 66"L
FV20M846072-... 72"L	FV21M846072-... 72"L
FV20M846078-... 78"L	FV21M846078-... 78"L
FV20M846084-... 84"L	FV21M846084-... 84"L
FV20M846090-... 90"L	FV21M846090-... 90"L
FV20M846096-... 96"L	FV21M846096-... 96"L

Double-sided – 9" Column Modules

Module Options:

The two final digits in the part numbers specifies the Accent Strip Material option and the Column Foot option for the workstation.

Accent Strip Material Options:

P = Plastic Laminate Panel
M = Powder Coated Steel Panel

Column Foot Options:

G = 1 1/2" Leveling Glide
C = 4" Swivel Locking Caster
H = 4" Heavy Duty Leveling Caster

Example: FV10M362424-P,G = with Laminate Accent Strip and Glides

36" High – 72" Deep

36" High

Starter

FV20M367224-	24"L
FV20M367230-	30"L
FV20M367236-	36"L
FV20M367242-	42"L
FV20M367248-	48"L
FV20M367254-	54"L
FV20M367260-	60"L
FV20M367266-	66"L
FV20M367272-	72"L
FV20M367278-	78"L
FV20M367284-	84"L
FV20M367290-	90"L
FV20M367296-	96"L

Add-on

FV21M367224-	24"L
FV21M367230-	30"L
FV21M367236-	36"L
FV21M367242-	42"L
FV21M367248-	48"L
FV21M367254-	54"L
FV21M367260-	60"L
FV21M367266-	66"L
FV21M367272-	72"L
FV21M367278-	78"L
FV21M367284-	84"L
FV21M367290-	90"L
FV21M367296-	96"L

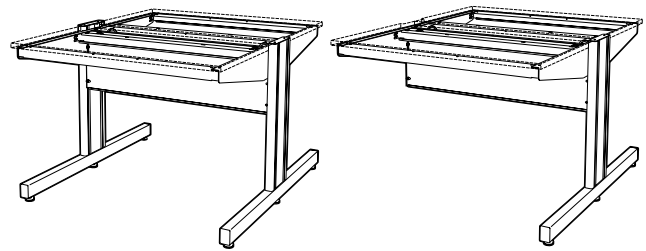

54" High – 72" Deep

54" High

Starter

FV20M547224-	24"L
FV20M547230-	30"L
FV20M547236-	36"L
FV20M547242-	42"L
FV20M547248-	48"L
FV20M547254-	54"L
FV20M547260-	60"L
FV20M547266-	66"L
FV20M547272-	72"L
FV20M547278-	78"L
FV20M547284-	84"L
FV20M547290-	90"L
FV20M547296-	96"L

Add-on

FV21M547224-	24"L
FV21M547230-	30"L
FV21M547236-	36"L
FV21M547242-	42"L
FV21M547248-	48"L
FV21M547254-	54"L
FV21M547260-	60"L
FV21M547266-	66"L
FV21M547272-	72"L
FV21M547278-	78"L
FV21M547284-	84"L
FV21M547290-	90"L
FV21M547296-	96"L

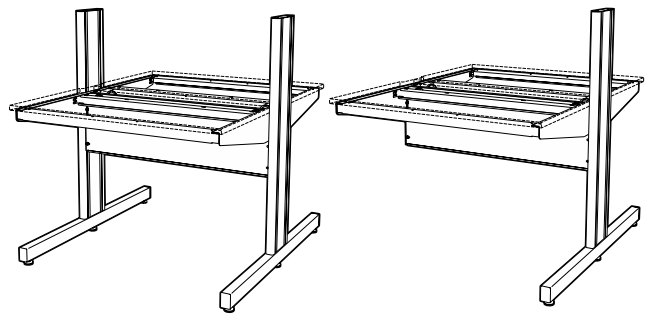

84" High – 72" Deep

84" High

Starter

FV20M847224-	24"L
FV20M847230-	30"L
FV20M847236-	36"L
FV20M847242-	42"L
FV20M847248-	48"L
FV20M847254-	54"L
FV20M847260-	60"L
FV20M847266-	66"L
FV20M847272-	72"L
FV20M847278-	78"L
FV20M847284-	84"L
FV20M847290-	90"L
FV20M847296-	96"L

Add-on

FV21M847224-	24"L
FV21M847230-	30"L
FV21M847236-	36"L
FV21M847242-	42"L
FV21M847248-	48"L
FV21M847254-	54"L
FV21M847260-	60"L
FV21M847266-	66"L
FV21M847272-	72"L
FV21M847278-	78"L
FV21M847284-	84"L
FV21M847290-	90"L
FV21M847296-	96"L

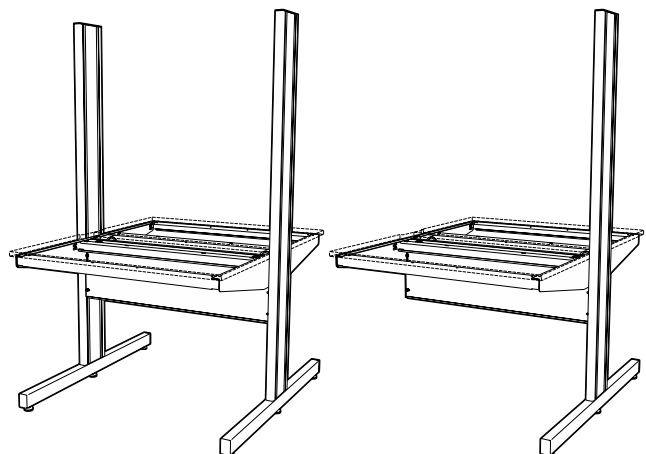

Single-sided – 12" Column Modules

Single-sided 12" Column Modules are available in three heights; 36", 54", and 84", three depths; 24", 30" and 36", and in lengths as shown — in both starter assemblies and add-on assemblies. Starter assemblies consist of two columns, a worksurface support frame, and all required

hardware. Add-on assemblies consist of one column, a worksurface support frame, and all required hardware. Workstation modules ship knocked-down for assembly in the field.

Work Tops must be specified separately. (see page 17)

36" High – 24" Deep

Starter	Add-on
FV30M362424- 24"L	FV31M362424- 24"L
FV30M362430- 30"L	FV31M362430- 30"L
FV30M362436- 36"L	FV31M362436- 36"L
FV30M362442- 42"L	FV31M362442- 42"L
FV30M362448- 48"L	FV31M362448- 48"L
FV30M362454- 54"L	FV31M362454- 54"L
FV30M362460- 60"L	FV31M362460- 60"L
FV30M362466- 66"L	FV31M362466- 66"L
FV30M362472- 72"L	FV31M362472- 72"L
FV30M362478- 78"L	FV31M362478- 78"L
FV30M362484- 84"L	FV31M362484- 84"L
FV30M362490- 90"L	FV31M362490- 90"L
FV30M362496- 96"L	FV31M362496- 96"L

36" High – 30" Deep

Starter	Add-on
FV30M363024- 24"L	FV31M363024- 24"L
FV30M363030- 30"L	FV31M363030- 30"L
FV30M363036- 36"L	FV31M363036- 36"L
FV30M363042- 42"L	FV31M363042- 42"L
FV30M363048- 48"L	FV31M363048- 48"L
FV30M363054- 54"L	FV31M363054- 54"L
FV30M363060- 60"L	FV31M363060- 60"L
FV30M363066- 66"L	FV31M363066- 66"L
FV30M363072- 72"L	FV31M363072- 72"L
FV30M363078- 78"L	FV31M363078- 78"L
FV30M363084- 84"L	FV31M363084- 84"L
FV30M363090- 90"L	FV31M363090- 90"L
FV30M363096- 96"L	FV31M363096- 96"L

54" High – 24" Deep

Starter	Add-on
FV30M542424- 24"L	FV31M542424- 24"L
FV30M542430- 30"L	FV31M542430- 30"L
FV30M542436- 36"L	FV31M542436- 36"L
FV30M542442- 42"L	FV31M542442- 42"L
FV30M542448- 48"L	FV31M542448- 48"L
FV30M542454- 54"L	FV31M542454- 54"L
FV30M542460- 60"L	FV31M542460- 60"L
FV30M542466- 66"L	FV31M542466- 66"L
FV30M542472- 72"L	FV31M542472- 72"L
FV30M542478- 78"L	FV31M542478- 78"L
FV30M542484- 84"L	FV31M542484- 84"L
FV30M542490- 90"L	FV31M542490- 90"L
FV30M542496- 96"L	FV31M542496- 96"L

54" High – 30" Deep

Starter	Add-on
FV30M543024- 24"L	FV31M543024- 24"L
FV30M543030- 30"L	FV31M543030- 30"L
FV30M543036- 36"L	FV31M543036- 36"L
FV30M543042- 42"L	FV31M543042- 42"L
FV30M543048- 48"L	FV31M543048- 48"L
FV30M543054- 54"L	FV31M543054- 54"L
FV30M543060- 60"L	FV31M543060- 60"L
FV30M543066- 66"L	FV31M543066- 66"L
FV30M543072- 72"L	FV31M543072- 72"L
FV30M543078- 78"L	FV31M543078- 78"L
FV30M543084- 84"L	FV31M543084- 84"L
FV30M543090- 90"L	FV31M543090- 90"L
FV30M543096- 96"L	FV31M543096- 96"L

84" High – 24" Deep

Starter	Add-on
FV30M842424- 24"L	FV31M842424- 24"L
FV30M842430- 30"L	FV31M842430- 30"L
FV30M842436- 36"L	FV31M842436- 36"L
FV30M842442- 42"L	FV31M842442- 42"L
FV30M842448- 48"L	FV31M842448- 48"L
FV30M842454- 54"L	FV31M842454- 54"L
FV30M842460- 60"L	FV31M842460- 60"L
FV30M842466- 66"L	FV31M842466- 66"L
FV30M842472- 72"L	FV31M842472- 72"L
FV30M842478- 78"L	FV31M842478- 78"L
FV30M842484- 84"L	FV31M842484- 84"L
FV30M842490- 90"L	FV31M842490- 90"L
FV30M842496- 96"L	FV31M842496- 96"L

84" High – 30" Deep

Starter	Add-on
FV30M843024- 24"L	FV31M843024- 24"L
FV30M843030- 30"L	FV31M843030- 30"L
FV30M843036- 36"L	FV31M843036- 36"L
FV30M843042- 42"L	FV31M843042- 42"L
FV30M843048- 48"L	FV31M843048- 48"L
FV30M843054- 54"L	FV31M843054- 54"L
FV30M843060- 60"L	FV31M843060- 60"L
FV30M843066- 66"L	FV31M843066- 66"L
FV30M843072- 72"L	FV31M843072- 72"L
FV30M843078- 78"L	FV31M843078- 78"L
FV30M843084- 84"L	FV31M843084- 84"L
FV30M843090- 90"L	FV31M843090- 90"L
FV30M843096- 96"L	FV31M843096- 96"L

Single-sided – 12" Column Modules

Module Options:

The two final digits in the part numbers specifies the Accent Strip Material option and the Column Foot option for the workstation.

Accent Strip Material Options:

P = Plastic Laminate Panel
M = Powder Coated Steel Panel

Column Foot Options:

G = 1 1/2" Leveling Glide
C = 4" Swivel Locking Caster
H = 4" Heavy Duty Leveling Caster

Example: FV10M362424-P,G = with Laminate Accent Strip and Glides

36" High – 36" Deep

36" High

Starter

FV30M363624-	24"L
FV30M363630-	30"L
FV30M363636-	36"L
FV30M363642-	42"L
FV30M363648-	48"L
FV30M363654-	54"L
FV30M363660-	60"L
FV30M363666-	66"L
FV30M363672-	72"L
FV30M363678-	78"L
FV30M363684-	84"L
FV30M363690-	90"L
FV30M363696-	96"L

Add-on

FV31M363624-	24"L
FV31M363630-	30"L
FV31M363636-	36"L
FV31M363642-	42"L
FV31M363648-	48"L
FV31M363654-	54"L
FV31M363660-	60"L
FV31M363666-	66"L
FV31M363672-	72"L
FV31M363678-	78"L
FV31M363684-	84"L
FV31M363690-	90"L
FV31M363696-	96"L

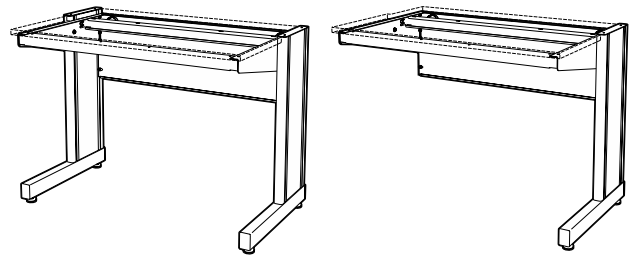

54" High – 36" Deep

54" High

Starter

FV30M543624-	24"L
FV30M543630-	30"L
FV30M543636-	36"L
FV30M543642-	42"L
FV30M543648-	48"L
FV30M543654-	54"L
FV30M543660-	60"L
FV30M543666-	66"L
FV30M543672-	72"L
FV30M543678-	78"L
FV30M543684-	84"L
FV30M543690-	90"L
FV30M543696-	96"L

Add-on

FV31M543624-	24"L
FV31M543630-	30"L
FV31M543636-	36"L
FV31M543642-	42"L
FV31M543648-	48"L
FV31M543654-	54"L
FV31M543660-	60"L
FV31M543666-	66"L
FV31M543672-	72"L
FV31M543678-	78"L
FV31M543684-	84"L
FV31M543690-	90"L
FV31M543696-	96"L

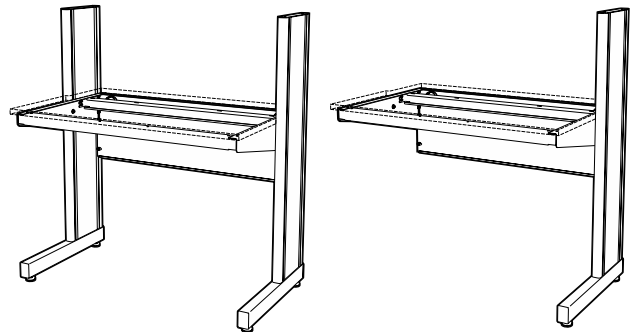

84" High – 36" Deep

84" High

Starter

FV30M843624-	24"L
FV30M843630-	30"L
FV30M843636-	36"L
FV30M843642-	42"L
FV30M843648-	48"L
FV30M843654-	54"L
FV30M843660-	60"L
FV30M843666-	66"L
FV30M843672-	72"L
FV30M843678-	78"L
FV30M843684-	84"L
FV30M843690-	90"L
FV30M843696-	96"L

Add-on

FV31M843624-	24"L
FV31M843630-	30"L
FV31M843636-	36"L
FV31M843642-	42"L
FV31M843648-	48"L
FV31M843654-	54"L
FV31M843660-	60"L
FV31M843666-	66"L
FV31M843672-	72"L
FV31M843678-	78"L
FV31M843684-	84"L
FV31M843690-	90"L
FV31M843696-	96"L

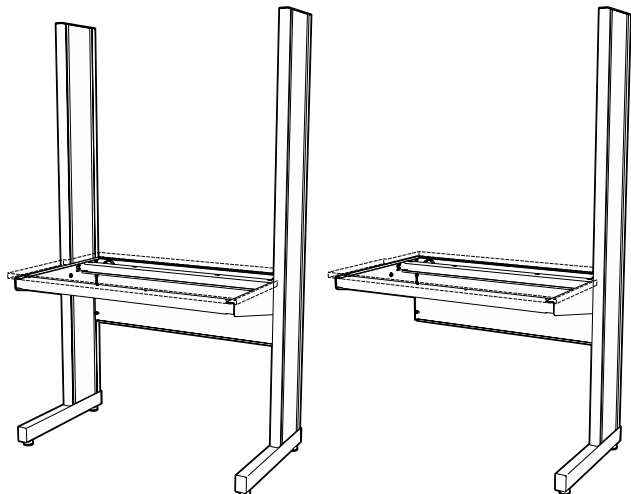

Double-sided – 12" Column Modules

Double-sided 12" Column Workstations are available in three heights; 36", 54", and 84", three depths; 48", 60" and 72", and in lengths as shown — in both starter assemblies and add-on assemblies. Starter assemblies consist of two columns, two worksurface support frames, and all

required hardware. Add-on assemblies consist of one column, two worksurface support frames, and all required hardware. Workstation modules ship knocked-down for assembly in the field.

Work Tops must be specified separately. (see page 17)

36" High – 48" Deep

Starter	Add-on
FV40M364824-... 24"L	FV41M364824-... 24"L
FV40M364830-... 30"L	FV41M364830-... 30"L
FV40M364836-... 36"L	FV41M364836-... 36"L
FV40M364842-... 42"L	FV41M364842-... 42"L
FV40M364848-... 48"L	FV41M364848-... 48"L
FV40M364854-... 54"L	FV41M364854-... 54"L
FV40M364860-... 60"L	FV41M364860-... 60"L
FV40M364866-... 66"L	FV41M364866-... 66"L
FV40M364872-... 72"L	FV41M364872-... 72"L
FV40M364878-... 78"L	FV41M364878-... 78"L
FV40M364884-... 84"L	FV41M364884-... 84"L
FV40M364890-... 90"L	FV41M364890-... 90"L
FV40M364896-... 96"L	FV41M364896-... 96"L

36" High – 60" Deep

Starter	Add-on
FV40M366024-... 24"L	FV41M366024-... 24"L
FV40M366030-... 30"L	FV41M366030-... 30"L
FV40M366036-... 36"L	FV41M366036-... 36"L
FV40M366042-... 42"L	FV41M366042-... 42"L
FV40M366048-... 48"L	FV41M366048-... 48"L
FV40M366054-... 54"L	FV41M366054-... 54"L
FV40M366060-... 60"L	FV41M366060-... 60"L
FV40M366066-... 66"L	FV41M366066-... 66"L
FV40M366072-... 72"L	FV41M366072-... 72"L
FV40M366078-... 78"L	FV41M366078-... 78"L
FV40M366084-... 84"L	FV41M366084-... 84"L
FV40M366090-... 90"L	FV41M366090-... 90"L
FV40M366096-... 96"L	FV41M366096-... 96"L

54" High – 48" Deep

Starter	Add-on
FV40M544824-... 24"L	FV41M544824-... 24"L
FV40M544830-... 30"L	FV41M544830-... 30"L
FV40M544836-... 36"L	FV41M544836-... 36"L
FV40M544842-... 42"L	FV41M544842-... 42"L
FV40M544848-... 48"L	FV41M544848-... 48"L
FV40M544854-... 54"L	FV41M544854-... 54"L
FV40M544860-... 60"L	FV41M544860-... 60"L
FV40M544866-... 66"L	FV41M544866-... 66"L
FV40M544872-... 72"L	FV41M544872-... 72"L
FV40M544878-... 78"L	FV41M544878-... 78"L
FV40M544884-... 84"L	FV41M544884-... 84"L
FV40M544890-... 90"L	FV41M544890-... 90"L
FV40M544896-... 96"L	FV41M544896-... 96"L

54" High – 60" Deep

Starter	Add-on
FV40M546024-... 24"L	FV41M546024-... 24"L
FV40M546030-... 30"L	FV41M546030-... 30"L
FV40M546036-... 36"L	FV41M546036-... 36"L
FV40M546042-... 42"L	FV41M546042-... 42"L
FV40M546048-... 48"L	FV41M546048-... 48"L
FV40M546054-... 54"L	FV41M546054-... 54"L
FV40M546060-... 60"L	FV41M546060-... 60"L
FV40M546066-... 66"L	FV41M546066-... 66"L
FV40M546072-... 72"L	FV41M546072-... 72"L
FV40M546078-... 78"L	FV41M546078-... 78"L
FV40M546084-... 84"L	FV41M546084-... 84"L
FV40M546090-... 90"L	FV41M546090-... 90"L
FV40M546096-... 96"L	FV41M546096-... 96"L

84" High – 48" Deep

Starter	Add-on
FV40M844824-... 24"L	FV41M844824-... 24"L
FV40M844830-... 30"L	FV41M844830-... 30"L
FV40M844836-... 36"L	FV41M844836-... 36"L
FV40M844842-... 42"L	FV41M844842-... 42"L
FV40M844848-... 48"L	FV41M844848-... 48"L
FV40M844854-... 54"L	FV41M844854-... 54"L
FV40M844860-... 60"L	FV41M844860-... 60"L
FV40M844866-... 66"L	FV41M844866-... 66"L
FV40M844872-... 72"L	FV41M844872-... 72"L
FV40M844878-... 78"L	FV41M844878-... 78"L
FV40M844884-... 84"L	FV41M844884-... 84"L
FV40M844890-... 90"L	FV41M844890-... 90"L
FV40M844896-... 96"L	FV41M844896-... 96"L

84" High – 60" Deep

Starter	Add-on
FV40M846024-... 24"L	FV41M846024-... 24"L
FV40M846030-... 30"L	FV41M846030-... 30"L
FV40M846036-... 36"L	FV41M846036-... 36"L
FV40M846042-... 42"L	FV41M846042-... 42"L
FV40M846048-... 48"L	FV41M846048-... 48"L
FV40M846054-... 54"L	FV41M846054-... 54"L
FV40M846060-... 60"L	FV41M846060-... 60"L
FV40M846066-... 66"L	FV41M846066-... 66"L
FV40M846072-... 72"L	FV41M846072-... 72"L
FV40M846078-... 78"L	FV41M846078-... 78"L
FV40M846084-... 84"L	FV41M846084-... 84"L
FV40M846090-... 90"L	FV41M846090-... 90"L
FV40M846096-... 96"L	FV41M846096-... 96"L

Double-sided – 12" Column Modules

Module Options:

The two final digits in the part numbers specifies the Accent Strip Material option and the Column Foot option for the workstation.

Accent Strip Material Options:

P = Plastic Laminate Panel
M = Powder Coated Steel Panel

Column Foot Options:

G = 1 1/2" Leveling Glide
C = 4" Swivel Locking Caster
H = 4" Heavy Duty Leveling Caster

Example: FV10M362424-P,G = with Laminate Accent Strip and Glides

36" High – 72" Deep

36" High

Starter

FV40M367224-	24"L
FV40M367230-	30"L
FV40M367236-	36"L
FV40M367242-	42"L
FV40M367248-	48"L
FV40M367254-	54"L
FV40M367260-	60"L
FV40M367266-	66"L
FV40M367272-	72"L
FV40M367278-	78"L
FV40M367284-	84"L
FV40M367290-	90"L
FV40M367296-	96"L

Add-on

FV41M367224-	24"L
FV41M367230-	30"L
FV41M367236-	36"L
FV41M367242-	42"L
FV41M367248-	48"L
FV41M367254-	54"L
FV41M367260-	60"L
FV41M367266-	66"L
FV41M367272-	72"L
FV41M367278-	78"L
FV41M367284-	84"L
FV41M367290-	90"L
FV41M367296-	96"L

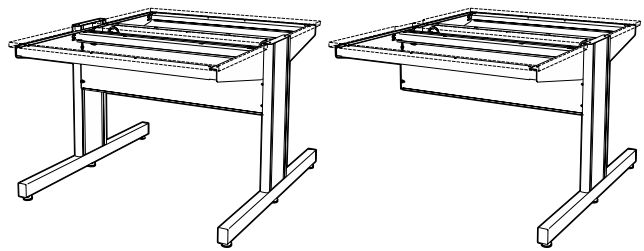

54" High – 72" Deep

54" High

Starter

FV40M547224-	24"L
FV40M547230-	30"L
FV40M547236-	36"L
FV40M547242-	42"L
FV40M547248-	48"L
FV40M547254-	54"L
FV40M547260-	60"L
FV40M547266-	66"L
FV40M547272-	72"L
FV40M547278-	78"L
FV40M547284-	84"L
FV40M547290-	90"L
FV40M547296-	96"L

Add-on

FV41M547224-	24"L
FV41M547230-	30"L
FV41M547236-	36"L
FV41M547242-	42"L
FV41M547248-	48"L
FV41M547254-	54"L
FV41M547260-	60"L
FV41M547266-	66"L
FV41M547272-	72"L
FV41M547278-	78"L
FV41M547284-	84"L
FV41M547290-	90"L
FV41M547296-	96"L

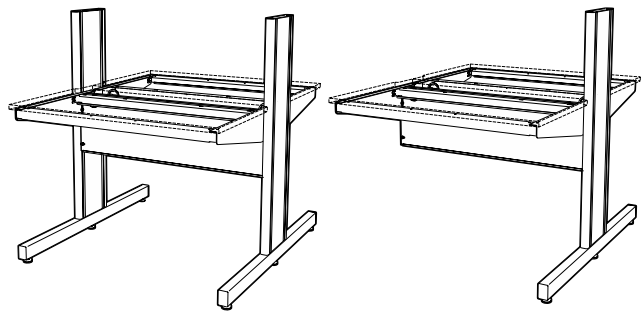

84" High – 72" Deep

84" High

Starter

FV40M847224-	24"L
FV40M847230-	30"L
FV40M847236-	36"L
FV40M847242-	42"L
FV40M847248-	48"L
FV40M847254-	54"L
FV40M847260-	60"L
FV40M847266-	66"L
FV40M847272-	72"L
FV40M847278-	78"L
FV40M847284-	84"L
FV40M847290-	90"L
FV40M847296-	96"L

Add-on

FV41M847224-	24"L
FV41M847230-	30"L
FV41M847236-	36"L
FV41M847242-	42"L
FV41M847248-	48"L
FV41M847254-	54"L
FV41M847260-	60"L
FV41M847266-	66"L
FV41M847272-	72"L
FV41M847278-	78"L
FV41M847284-	84"L
FV41M847290-	90"L
FV41M847296-	96"L

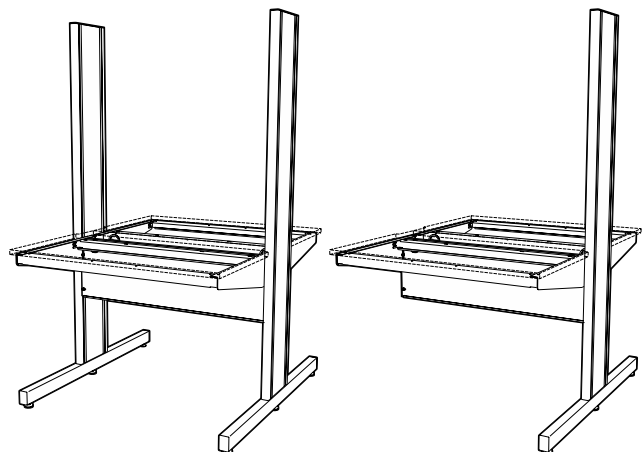

Work Tops

Work Tops are available in four materials, 1" thick and with or without an extra 1" of length on either the left, right, or both ends to extend the length of the top to be even with the outside of the column. See page 4 for available color options.

Work Top Material Codes:

- R** = Kemresin
- T** = Phenolic Resin

Example: FV90**R**013060-**RB**
Standard length Kemresin top

Extended Length Option:

- S** = Standard Length
- L** = Extended on Left End
- R** = Extended on Right End
- B** = Extended on Both Ends

Example: FV91**R**016060-**RB**
Work top extended both ends

Work Top for Single-sided 9" Column Workstation

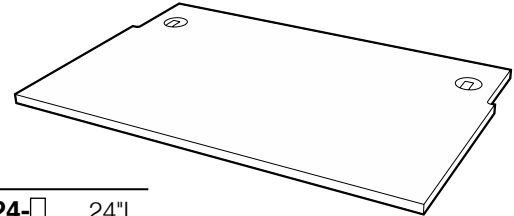

24" Deep

FV90	<input type="checkbox"/>	012424-	<input type="checkbox"/>	24"L
FV90	<input type="checkbox"/>	012430-	<input type="checkbox"/>	30"L
FV90	<input type="checkbox"/>	012436-	<input type="checkbox"/>	36"L
FV90	<input type="checkbox"/>	012442-	<input type="checkbox"/>	42"L
FV90	<input type="checkbox"/>	012448-	<input type="checkbox"/>	48"L
FV90	<input type="checkbox"/>	012454-	<input type="checkbox"/>	54"L
FV90	<input type="checkbox"/>	012460-	<input type="checkbox"/>	60"L
FV90	<input type="checkbox"/>	012466-	<input type="checkbox"/>	66"L
FV90	<input type="checkbox"/>	012472-	<input type="checkbox"/>	72"L
FV90	<input type="checkbox"/>	012478-	<input type="checkbox"/>	78"L
FV90	<input type="checkbox"/>	012484-	<input type="checkbox"/>	84"L
FV90	<input type="checkbox"/>	012490-	<input type="checkbox"/>	90"L
FV90	<input type="checkbox"/>	012496-	<input type="checkbox"/>	96"L

30" Deep

FV90	<input type="checkbox"/>	013024-	<input type="checkbox"/>	24"L
FV90	<input type="checkbox"/>	013030-	<input type="checkbox"/>	30"L
FV90	<input type="checkbox"/>	013036-	<input type="checkbox"/>	36"L
FV90	<input type="checkbox"/>	013042-	<input type="checkbox"/>	42"L
FV90	<input type="checkbox"/>	013048-	<input type="checkbox"/>	48"L
FV90	<input type="checkbox"/>	013054-	<input type="checkbox"/>	54"L
FV90	<input type="checkbox"/>	013060-	<input type="checkbox"/>	60"L
FV90	<input type="checkbox"/>	013066-	<input type="checkbox"/>	66"L
FV90	<input type="checkbox"/>	013072-	<input type="checkbox"/>	72"L
FV90	<input type="checkbox"/>	013078-	<input type="checkbox"/>	78"L
FV90	<input type="checkbox"/>	013084-	<input type="checkbox"/>	84"L
FV90	<input type="checkbox"/>	013090-	<input type="checkbox"/>	90"L
FV90	<input type="checkbox"/>	013096-	<input type="checkbox"/>	96"L

36" Deep

FV90	<input type="checkbox"/>	013624-	<input type="checkbox"/>	24"L
FV90	<input type="checkbox"/>	013630-	<input type="checkbox"/>	30"L
FV90	<input type="checkbox"/>	013636-	<input type="checkbox"/>	36"L
FV90	<input type="checkbox"/>	013642-	<input type="checkbox"/>	42"L
FV90	<input type="checkbox"/>	013648-	<input type="checkbox"/>	48"L
FV90	<input type="checkbox"/>	013654-	<input type="checkbox"/>	54"L
FV90	<input type="checkbox"/>	013660-	<input type="checkbox"/>	60"L
FV90	<input type="checkbox"/>	013666-	<input type="checkbox"/>	66"L
FV90	<input type="checkbox"/>	013672-	<input type="checkbox"/>	72"L
FV90	<input type="checkbox"/>	013678-	<input type="checkbox"/>	78"L
FV90	<input type="checkbox"/>	013684-	<input type="checkbox"/>	84"L
FV90	<input type="checkbox"/>	013690-	<input type="checkbox"/>	90"L
FV90	<input type="checkbox"/>	013696-	<input type="checkbox"/>	96"L

Work Top for Double-sided 9" Column Workstation

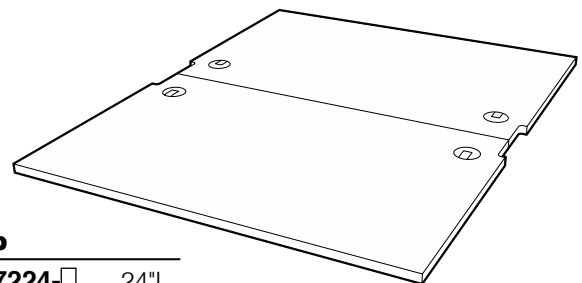

48" Deep

FV91	<input type="checkbox"/>	014824-	<input type="checkbox"/>	24"L
FV91	<input type="checkbox"/>	014830-	<input type="checkbox"/>	30"L
FV91	<input type="checkbox"/>	014836-	<input type="checkbox"/>	36"L
FV91	<input type="checkbox"/>	014842-	<input type="checkbox"/>	42"L
FV91	<input type="checkbox"/>	014848-	<input type="checkbox"/>	48"L
FV91	<input type="checkbox"/>	014854-	<input type="checkbox"/>	54"L
FV91	<input type="checkbox"/>	014860-	<input type="checkbox"/>	60"L
FV91	<input type="checkbox"/>	014866-	<input type="checkbox"/>	66"L
FV91	<input type="checkbox"/>	014872-	<input type="checkbox"/>	72"L
FV91	<input type="checkbox"/>	014878-	<input type="checkbox"/>	78"L
FV91	<input type="checkbox"/>	014884-	<input type="checkbox"/>	84"L
FV91	<input type="checkbox"/>	014890-	<input type="checkbox"/>	90"L
FV91	<input type="checkbox"/>	014896-	<input type="checkbox"/>	96"L

60" Deep

FV91	<input type="checkbox"/>	016024-	<input type="checkbox"/>	24"L
FV91	<input type="checkbox"/>	016030-	<input type="checkbox"/>	30"L
FV91	<input type="checkbox"/>	016036-	<input type="checkbox"/>	36"L
FV91	<input type="checkbox"/>	016042-	<input type="checkbox"/>	42"L
FV91	<input type="checkbox"/>	016048-	<input type="checkbox"/>	48"L
FV91	<input type="checkbox"/>	016054-	<input type="checkbox"/>	54"L
FV91	<input type="checkbox"/>	016060-	<input type="checkbox"/>	60"L
FV91	<input type="checkbox"/>	016066-	<input type="checkbox"/>	66"L
FV91	<input type="checkbox"/>	016072-	<input type="checkbox"/>	72"L
FV91	<input type="checkbox"/>	016078-	<input type="checkbox"/>	78"L
FV91	<input type="checkbox"/>	016084-	<input type="checkbox"/>	84"L
FV91	<input type="checkbox"/>	016090-	<input type="checkbox"/>	90"L
FV91	<input type="checkbox"/>	016096-	<input type="checkbox"/>	96"L

72" Deep

FV91	<input type="checkbox"/>	017224-	<input type="checkbox"/>	24"L
FV91	<input type="checkbox"/>	017230-	<input type="checkbox"/>	30"L
FV91	<input type="checkbox"/>	017236-	<input type="checkbox"/>	36"L
FV91	<input type="checkbox"/>	017242-	<input type="checkbox"/>	42"L
FV91	<input type="checkbox"/>	017248-	<input type="checkbox"/>	48"L
FV91	<input type="checkbox"/>	017254-	<input type="checkbox"/>	54"L
FV91	<input type="checkbox"/>	017260-	<input type="checkbox"/>	60"L
FV91	<input type="checkbox"/>	017266-	<input type="checkbox"/>	66"L
FV91	<input type="checkbox"/>	017272-	<input type="checkbox"/>	72"L
FV91	<input type="checkbox"/>	017278-	<input type="checkbox"/>	78"L
FV91	<input type="checkbox"/>	017284-	<input type="checkbox"/>	84"L
FV91	<input type="checkbox"/>	017290-	<input type="checkbox"/>	90"L
FV91	<input type="checkbox"/>	017296-	<input type="checkbox"/>	96"L

Work Tops

Work Tops are available in four materials, 1" thick and with or without an extra 1" of length on either the left, right, or both ends to extend the length of the top to be even with the outside of the column. See page 4 for available color options.

Work Top Material Codes:

R = Kemresin
T = Phenolic Resin

Example: FV92**R**013060-**RB**
 Standard length Kemresin top

Extended Length Option:

S = Standard Length
 L = Extended on Left End
 R = Extended on Right End
 B = Extended on Both Ends

Example: FV93**T**016060-**TB**
 Work top extended both ends

Work Top for Single-sided 12" Column Workstation

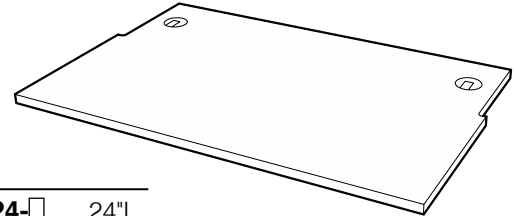

24" Deep

FV92	<input type="checkbox"/>	012424	<input type="checkbox"/>	24"L
FV92	<input type="checkbox"/>	012430	<input type="checkbox"/>	30"L
FV92	<input type="checkbox"/>	012436	<input type="checkbox"/>	36"L
FV92	<input type="checkbox"/>	012442	<input type="checkbox"/>	42"L
FV92	<input type="checkbox"/>	012448	<input type="checkbox"/>	48"L
FV92	<input type="checkbox"/>	012454	<input type="checkbox"/>	54"L
FV92	<input type="checkbox"/>	012460	<input type="checkbox"/>	60"L
FV92	<input type="checkbox"/>	012466	<input type="checkbox"/>	66"L
FV92	<input type="checkbox"/>	012472	<input type="checkbox"/>	72"L
FV92	<input type="checkbox"/>	012478	<input type="checkbox"/>	78"L
FV92	<input type="checkbox"/>	012484	<input type="checkbox"/>	84"L
FV92	<input type="checkbox"/>	012490	<input type="checkbox"/>	90"L
FV92	<input type="checkbox"/>	012496	<input type="checkbox"/>	96"L

30" Deep

FV92	<input type="checkbox"/>	013024	<input type="checkbox"/>	24"L
FV92	<input type="checkbox"/>	013030	<input type="checkbox"/>	30"L
FV92	<input type="checkbox"/>	013036	<input type="checkbox"/>	36"L
FV92	<input type="checkbox"/>	013042	<input type="checkbox"/>	42"L
FV92	<input type="checkbox"/>	013048	<input type="checkbox"/>	48"L
FV92	<input type="checkbox"/>	013054	<input type="checkbox"/>	54"L
FV92	<input type="checkbox"/>	013060	<input type="checkbox"/>	60"L
FV92	<input type="checkbox"/>	013066	<input type="checkbox"/>	66"L
FV92	<input type="checkbox"/>	013072	<input type="checkbox"/>	72"L
FV92	<input type="checkbox"/>	013078	<input type="checkbox"/>	78"L
FV92	<input type="checkbox"/>	013084	<input type="checkbox"/>	84"L
FV92	<input type="checkbox"/>	013090	<input type="checkbox"/>	90"L
FV92	<input type="checkbox"/>	013096	<input type="checkbox"/>	96"L

36" Deep

FV92	<input type="checkbox"/>	013624	<input type="checkbox"/>	24"L
FV92	<input type="checkbox"/>	013630	<input type="checkbox"/>	30"L
FV92	<input type="checkbox"/>	013636	<input type="checkbox"/>	36"L
FV92	<input type="checkbox"/>	013642	<input type="checkbox"/>	42"L
FV92	<input type="checkbox"/>	013648	<input type="checkbox"/>	48"L
FV92	<input type="checkbox"/>	013654	<input type="checkbox"/>	54"L
FV92	<input type="checkbox"/>	013660	<input type="checkbox"/>	60"L
FV92	<input type="checkbox"/>	013666	<input type="checkbox"/>	66"L
FV92	<input type="checkbox"/>	013672	<input type="checkbox"/>	72"L
FV92	<input type="checkbox"/>	013678	<input type="checkbox"/>	78"L
FV92	<input type="checkbox"/>	013684	<input type="checkbox"/>	84"L
FV92	<input type="checkbox"/>	013690	<input type="checkbox"/>	90"L
FV92	<input type="checkbox"/>	013696	<input type="checkbox"/>	96"L

Work Top for Double-sided 12" Column Workstation

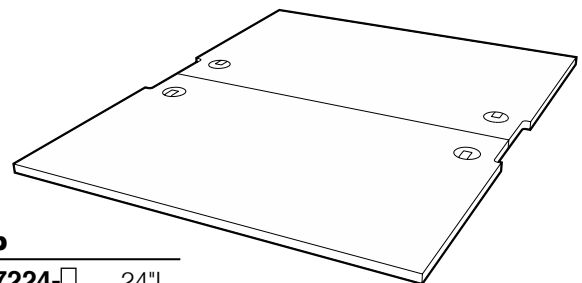

48" Deep

FV93	<input type="checkbox"/>	014824	<input type="checkbox"/>	24"L
FV93	<input type="checkbox"/>	014830	<input type="checkbox"/>	30"L
FV93	<input type="checkbox"/>	014836	<input type="checkbox"/>	36"L
FV93	<input type="checkbox"/>	014842	<input type="checkbox"/>	42"L
FV93	<input type="checkbox"/>	014848	<input type="checkbox"/>	48"L
FV93	<input type="checkbox"/>	014854	<input type="checkbox"/>	54"L
FV93	<input type="checkbox"/>	014860	<input type="checkbox"/>	60"L
FV93	<input type="checkbox"/>	014866	<input type="checkbox"/>	66"L
FV93	<input type="checkbox"/>	014872	<input type="checkbox"/>	72"L
FV93	<input type="checkbox"/>	014878	<input type="checkbox"/>	78"L
FV93	<input type="checkbox"/>	014884	<input type="checkbox"/>	84"L
FV93	<input type="checkbox"/>	014890	<input type="checkbox"/>	90"L
FV93	<input type="checkbox"/>	014896	<input type="checkbox"/>	96"L

60" Deep

FV93	<input type="checkbox"/>	016024	<input type="checkbox"/>	24"L
FV93	<input type="checkbox"/>	016030	<input type="checkbox"/>	30"L
FV93	<input type="checkbox"/>	016036	<input type="checkbox"/>	36"L
FV93	<input type="checkbox"/>	016042	<input type="checkbox"/>	42"L
FV93	<input type="checkbox"/>	016048	<input type="checkbox"/>	48"L
FV93	<input type="checkbox"/>	016054	<input type="checkbox"/>	54"L
FV93	<input type="checkbox"/>	016060	<input type="checkbox"/>	60"L
FV93	<input type="checkbox"/>	016066	<input type="checkbox"/>	66"L
FV93	<input type="checkbox"/>	016072	<input type="checkbox"/>	72"L
FV93	<input type="checkbox"/>	016078	<input type="checkbox"/>	78"L
FV93	<input type="checkbox"/>	016084	<input type="checkbox"/>	84"L
FV93	<input type="checkbox"/>	016090	<input type="checkbox"/>	90"L
FV93	<input type="checkbox"/>	016096	<input type="checkbox"/>	96"L

72" Deep

FV93	<input type="checkbox"/>	017224	<input type="checkbox"/>	24"L
FV93	<input type="checkbox"/>	017230	<input type="checkbox"/>	30"L
FV93	<input type="checkbox"/>	017236	<input type="checkbox"/>	36"L
FV93	<input type="checkbox"/>	017242	<input type="checkbox"/>	42"L
FV93	<input type="checkbox"/>	017248	<input type="checkbox"/>	48"L
FV93	<input type="checkbox"/>	017254	<input type="checkbox"/>	54"L
FV93	<input type="checkbox"/>	017260	<input type="checkbox"/>	60"L
FV93	<input type="checkbox"/>	017266	<input type="checkbox"/>	66"L
FV93	<input type="checkbox"/>	017272	<input type="checkbox"/>	72"L
FV93	<input type="checkbox"/>	017278	<input type="checkbox"/>	78"L
FV93	<input type="checkbox"/>	017284	<input type="checkbox"/>	84"L
FV93	<input type="checkbox"/>	017290	<input type="checkbox"/>	90"L
FV93	<input type="checkbox"/>	017296	<input type="checkbox"/>	96"L

Corner Modules – 9" Column

Evolution Corner Modules are designed to be added to two workstation modules to create an "L" shaped assembly. They are available in two different configurations; square or diagonal and in three depths; 24", 30", and 36" to match workstation depths.

Square Corner Support Frames include: two support brackets, and an adjustable height rear corner support leg.

Diagonal Corner Support Frames include: two support brackets, a front apron, two modesty panels, and an adjustable height rear corner support leg.

Work Tops must be specified separately.

Work Tops are available in four materials. See page 4 for available color options.

Work Top Material Codes:

- R** = Kemresin
- T** = Phenolic Resin

Example: FV94T013032

Square Corner **Phenolic Resin** Work Top

Square Corner Support Frame – 9" Column

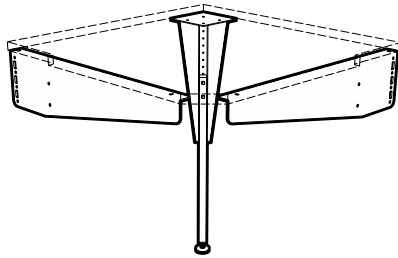

- FV14M362426** 24"D x 26"L
- FV14M363032** 30"D x 32"L
- FV14M363638** 36"D x 38"L

Square Corner Work Top – 9" Column

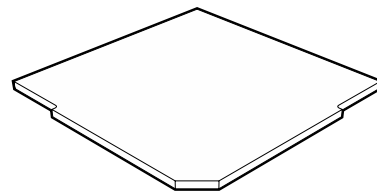

- FV94□012426** 24"D x 26"L
- FV94□013032** 30"D x 32"L
- FV94□013638** 36"D x 38"L

Diagonal Corner Support Frame – 9" Column

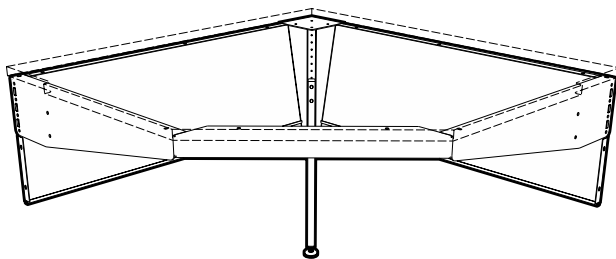

- FV15M362440** 24"D x 40"L
- FV15M363046** 30"D x 46"L
- FV15M363652** 36"D x 52"L

Diagonal Corner Work Top – 9" Column

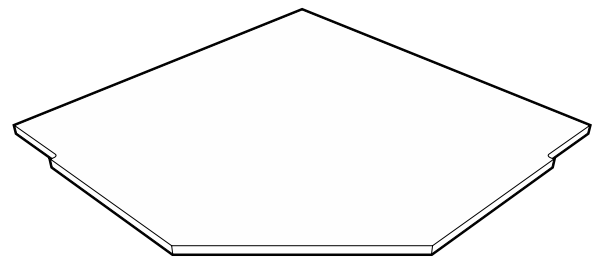

- FV95□012440** 24"D x 40"L
- FV95□013046** 30"D x 46"L
- FV95□013652** 36"D x 52"L

Corner Modules – 12" Column

Evolution Corner Modules are designed to be added to two workstation modules to create an “L” shaped assembly. They are available in two different configurations; square or diagonal and in three depths; 24”, 30”, and 36” to match workstation depths.

Square Corner Support Frames include: two support brackets, and an adjustable height rear corner support leg.

Diagonal Corner Support Frames include: two support brackets, a front apron, two modesty panels, and an adjustable height rear corner support leg.

Work Tops must be specified separately.

Work Tops are available in four materials. See page 4 for available color options.

Work Top Material Codes:

- R = Kemresin
- T = Phenolic Resin

Example: FV97T013046

Diagonal Corner **Phenolic Resin** Work Top

Square Corner Support Frame — 12" Column

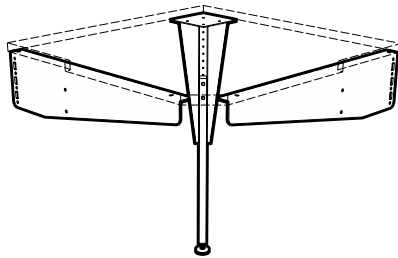

- FV34M362426 24"D x 26"L
- FV34M363032 30"D x 32"L
- FV34M363638 36"D x 38"L

Square Corner Work Top — 12" Column

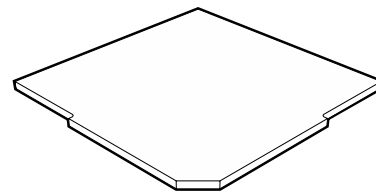

- FV96□012426 24"D x 26"L
- FV96□013032 30"D x 32"L
- FV96□013638 36"D x 38"L

Diagonal Corner Support Frame — 12" Column

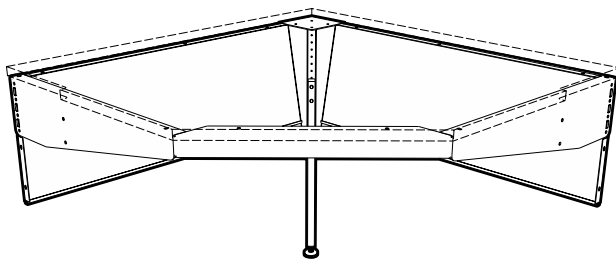

- FV35M362440 24"D x 40"L
- FV35M363046 30"D x 46"L
- FV35M363652 36"D x 52"L

Diagonal Corner Work Top — 12" Column

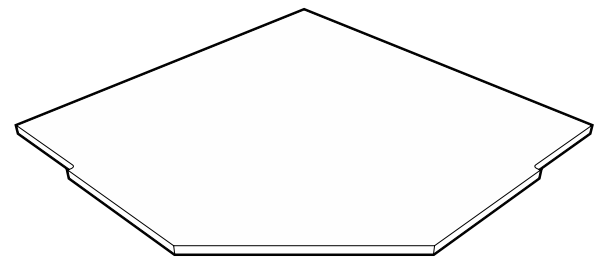

- FV97□012440 24"D x 40"L
- FV97□013046 30"D x 46"L
- FV97□013652 36"D x 52"L

Columns

Columns are available individually for replacement purposes and custom applications.

The two final digits in the part number specifies the Accent Strip Material option and the Foot option for the column.

Accent Strip Material Options:

- P** = Plastic Laminate Panel
- M** = Powder Coated Steel Panel

Workstation Foot Options:

- G** = 1 1/2" Leveling Glide
- C** = 4" Swivel Locking Caster
- H** = 4" Heavy Duty Leveling Caster

Example: FV01M36301-M,G = with Steel Accent Panel and Glides

9" Single-sided Columns

36" High

- FV01M362402-_- 24"D
- FV01M363002-_- 30"D
- FV01M363602-_- 36"D

54" High

- FV01M542402-_- 24"D
- FV01M543002-_- 30"D
- FV01M543602-_- 36"D

84" High

- FV01M842402-_- 24"D
- FV01M843002-_- 30"D
- FV01M843602-_- 36"D

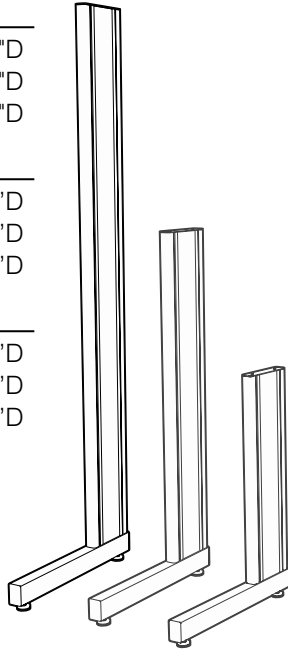

9" Double-sided Columns

36" High

- FV02M364802-_- 48"D
- FV02M366002-_- 60"D
- FV02M367202-_- 72"D

54" High

- FV02M544802-_- 48"D
- FV02M546002-_- 60"D
- FV02M547202-_- 72"D

84" High

- FV02M844802-_- 48"D
- FV02M846002-_- 60"D
- FV02M847202-_- 72"D

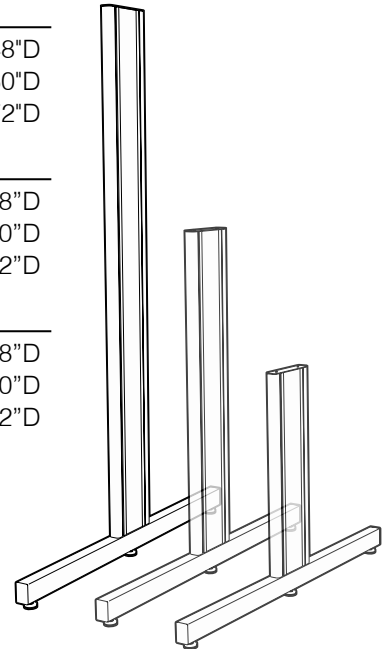

12" Single-sided Columns

36" High

- FV03M362402-_- 24"D
- FV03M363002-_- 30"D
- FV03M363602-_- 36"D

54" High

- FV03M542402-_- 24"D
- FV03M543002-_- 30"D
- FV03M543602-_- 36"D

84" High

- FV03M842402-_- 24"D
- FV03M843002-_- 30"D
- FV03M843602-_- 36"D

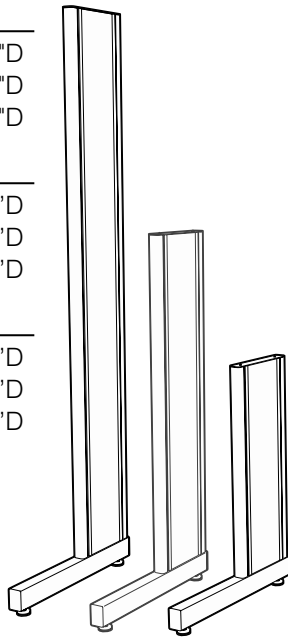

12" Double-sided Columns

36" High

- FV04M364802-_- 48"D
- FV04M366002-_- 60"D
- FV04M367202-_- 72"D

54" High

- FV04M544802-_- 48"D
- FV04M546002-_- 60"D
- FV04M547202-_- 72"D

84" High

- FV04M844802-_- 48"D
- FV04M846002-_- 60"D
- FV04M847202-_- 72"D

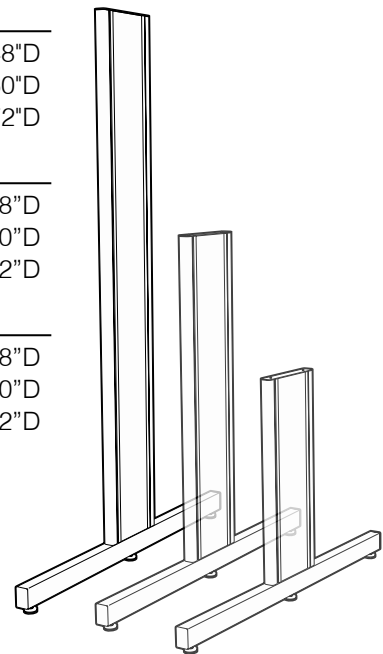

Evolution Shelving

Shelf Assembly Part Number Explanation

FV 60M 031536 - 09, L0

System Type

FV = Evolution

Shelf Type

- 60 = Single-sided Undermount
- 62 = Single-sided Bookend
- 64 = Double-sided Bookend
- 66 = Center Undermount
- 68 = Double-sided Undermount

Shelf Material

M = Powder Coated Steel

Options (see below)

Shelf Length

Standard Lengths: 24" - 30" - 36" - 42" - 48"
54" - 60" - 66" - 72" - 78" - 84" - 90" - 96"

Shelf Depth

Standard Depths: 12" - 15" - 18" - 24" - 30" - 36"

Shelf Bracket Height

Standard Heights: 2" - 3" - 5"

Shelf Options

FV 60M 031536 - 09, L0

Column Depth

- 09 = Shelf for 9" Column
- 12 = Shelf for 12" Column

Shelf Lip Option

- L0 = No Shelf Lips
- L1 = One Shelf Lip
- L2 = Two Shelf Lips (front & back)
- L3 = Three Shelf Lips (for FV66 Center Shelving)

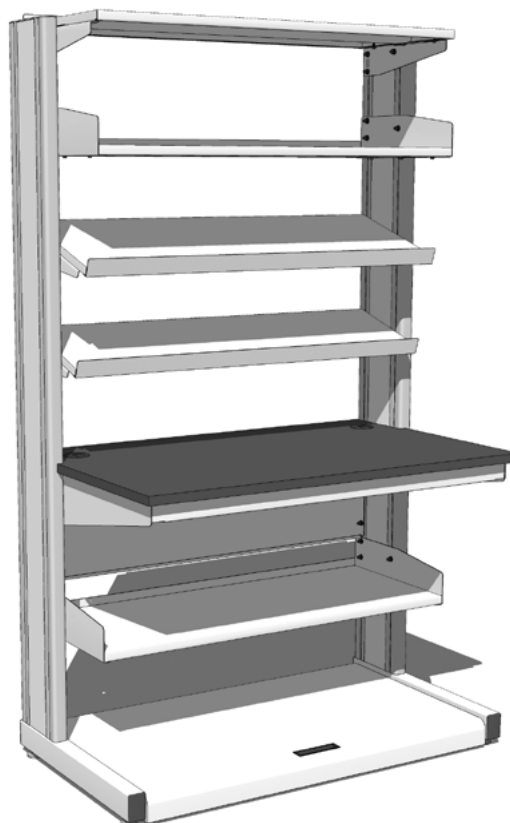

Single-sided Shelving

Single-sided Undermount Shelves consist of a pair of powder coated, 12 gauge steel shelf brackets and a 1" thick, powder coated, 14 gauge steel shelf. Shelves are infinitely height adjustable from above the worksurface to the top of the column and have limited mounting below

worksurface. Shelves mount flush with the rear of workstation columns and are available with or without retaining lips.

Column Depth Options:

- 09** = for 9" Deep Columns
- 12** = for 12" Deep Columns

Shelf Retaining Lip Options:

- L0** = No shelf lip
- L1** = Shelf Lip on one edge
- L2** = Shelf Lip on both edges

Example: FV60M031236-09,L1
= Shelf for 9" Column with Lip on one edge

Single-sided Undermount Shelving

12" Deep

FV60M031224-___,___	24"L
FV60M031230-___,___	30"L
FV60M031236-___,___	36"L
FV60M031242-___,___	42"L
FV60M031248-___,___	48"L
FV60M031254-___,___	54"L
FV60M031260-___,___	60"L
FV60M031266-___,___	66"L
FV60M031272-___,___	72"L
FV60M031278-___,___	78"L
FV60M031284-___,___	84"L
FV60M031290-___,___	90"L
FV60M031296-___,___	96"L

15" Deep

FV60M031524-___,___	24"L
FV60M031530-___,___	30"L
FV60M031536-___,___	36"L
FV60M031542-___,___	42"L
FV60M031548-___,___	48"L
FV60M031554-___,___	54"L
FV60M031560-___,___	60"L
FV60M031566-___,___	66"L
FV60M031572-___,___	72"L
FV60M031578-___,___	78"L
FV60M031584-___,___	84"L
FV60M031590-___,___	90"L
FV60M031596-___,___	96"L

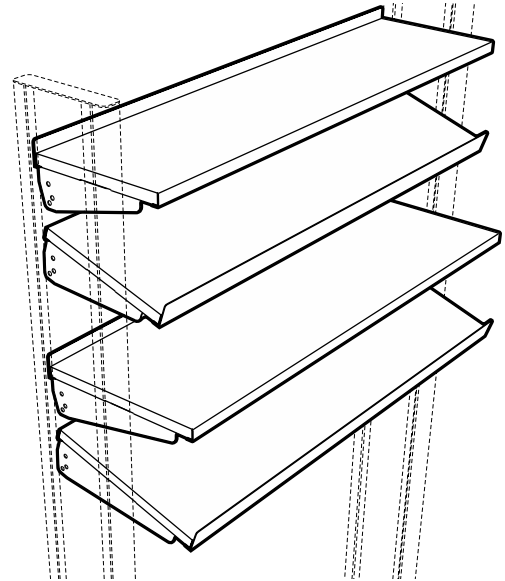

18" Deep

FV60M031824-___,___	24"L
FV60M031830-___,___	30"L
FV60M031836-___,___	36"L
FV60M031842-___,___	42"L
FV60M031848-___,___	48"L
FV60M031854-___,___	54"L
FV60M031860-___,___	60"L
FV60M031866-___,___	66"L
FV60M031872-___,___	72"L
FV60M031878-___,___	78"L
FV60M031884-___,___	84"L
FV60M031890-___,___	90"L
FV60M031896-___,___	96"L

24" Deep

FV60M032424-___,___	24"L
FV60M032430-___,___	30"L
FV60M032436-___,___	36"L
FV60M032442-___,___	42"L
FV60M032448-___,___	48"L
FV60M032454-___,___	54"L
FV60M032460-___,___	60"L
FV60M032466-___,___	66"L
FV60M032472-___,___	72"L
FV60M032478-___,___	78"L
FV60M032484-___,___	84"L
FV60M032490-___,___	90"L
FV60M032496-___,___	96"L

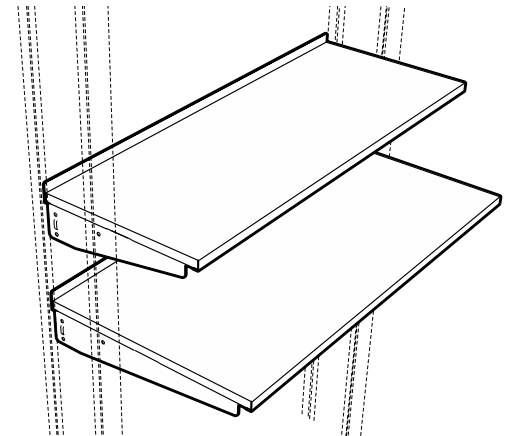

Single-sided Shelving

Single-sided Bookend Shelves consist of a pair of powder coated, 5" high, 12 gauge steel shelf brackets and a 1" thick, powder coated, 14 gauge steel shelf. Shelves are infinitely height adjustable from above the worksurface to the top of the column and have limited mounting

below worksurface. Shelves mount flush with the rear of workstation columns and are available with or without retaining lips.

Column Depth Options:

- 09** = for 9" Deep Columns
- 12** = for 12" Deep Columns

Shelf Retaining Lip Options:

- L0** = No shelf lip
- L1** = Shelf Lip on one edge
- L2** = Shelf Lip on both edges

Example: FV62M051236-09,L2 = Shelf for 9" Column with Lip on both front and back edge.

Single-sided Bookend Shelving

12" Deep

FV62M051224-___,___	24"L
FV62M051230-___,___	30"L
FV62M051236-___,___	36"L
FV62M051242-___,___	42"L
FV62M051248-___,___	48"L
FV62M051254-___,___	54"L
FV62M051260-___,___	60"L
FV62M051266-___,___	66"L
FV62M051272-___,___	72"L
FV62M051278-___,___	78"L
FV62M051284-___,___	84"L
FV62M051290-___,___	90"L
FV62M051296-___,___	96"L

15" Deep

FV62M051524-___,___	24"L
FV62M051530-___,___	30"L
FV62M051536-___,___	36"L
FV62M051542-___,___	42"L
FV62M051548-___,___	48"L
FV62M051554-___,___	54"L
FV62M051560-___,___	60"L
FV62M051566-___,___	66"L
FV62M051572-___,___	72"L
FV62M051578-___,___	78"L
FV62M051584-___,___	84"L
FV62M051590-___,___	90"L
FV62M051596-___,___	96"L

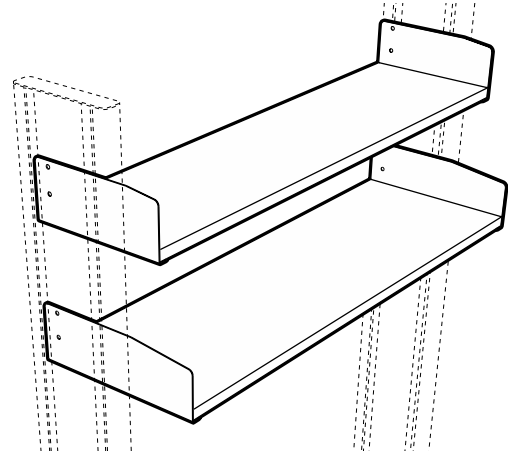

18" Deep

FV62M051824-___,___	24"L
FV62M051830-___,___	30"L
FV62M051836-___,___	36"L
FV62M051842-___,___	42"L
FV62M051848-___,___	48"L
FV62M051854-___,___	54"L
FV62M051860-___,___	60"L
FV62M051866-___,___	66"L
FV62M051872-___,___	72"L
FV62M051878-___,___	78"L
FV62M051884-___,___	84"L
FV62M051890-___,___	90"L
FV62M051896-___,___	96"L

24" Deep

FV62M052424-___,___	24"L
FV62M052430-___,___	30"L
FV62M052436-___,___	36"L
FV62M052442-___,___	42"L
FV62M052448-___,___	48"L
FV62M052454-___,___	54"L
FV62M052460-___,___	60"L
FV62M052466-___,___	66"L
FV62M052472-___,___	72"L
FV62M052478-___,___	78"L
FV62M052484-___,___	84"L
FV62M052490-___,___	90"L
FV62M052496-___,___	96"L

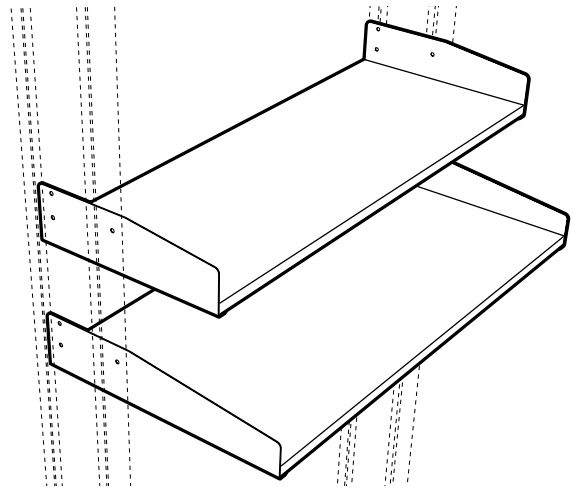

Double-sided Shelving

Double-sided Undermount Shelves consist of a pair of powder coated, 12 gauge steel shelf brackets and a 1" thick, powder coated, 14 gauge steel shelf. Shelves are infinitely height adjustable from above the worksurface to the top of the column and have limited mounting below the

worksurface. The rear edge of the shelf is centered on the workstation column and are available with or without retaining lips.

Column Depth Options:

- 09** = for 9" Deep Columns
- 12** = for 12" Deep Columns

Shelf Retaining Lip Options:

- L0** = No shelf lip
- L1** = Shelf Lip on one edge
- L2** = Shelf Lip on both edges

Example: FV68M031236-12,L1
= Shelf for 12" Column with Lip on one edge.

Double-sided Undermount Shelving

12" Deep

FV68M031224-___	24"L
FV68M031230-___	30"L
FV68M031236-___	36"L
FV68M031242-___	42"L
FV68M031248-___	48"L
FV68M031254-___	54"L
FV68M031260-___	60"L
FV68M031266-___	66"L
FV68M031272-___	72"L
FV68M031278-___	78"L
FV68M031284-___	84"L
FV68M031290-___	90"L
FV68M031296-___	96"L

15" Deep

FV68M031524-___	24"L
FV68M031530-___	30"L
FV68M031536-___	36"L
FV68M031542-___	42"L
FV68M031548-___	48"L
FV68M031554-___	54"L
FV68M031560-___	60"L
FV68M031566-___	66"L
FV68M031572-___	72"L
FV68M031578-___	78"L
FV68M031584-___	84"L
FV68M031590-___	90"L
FV68M031596-___	96"L

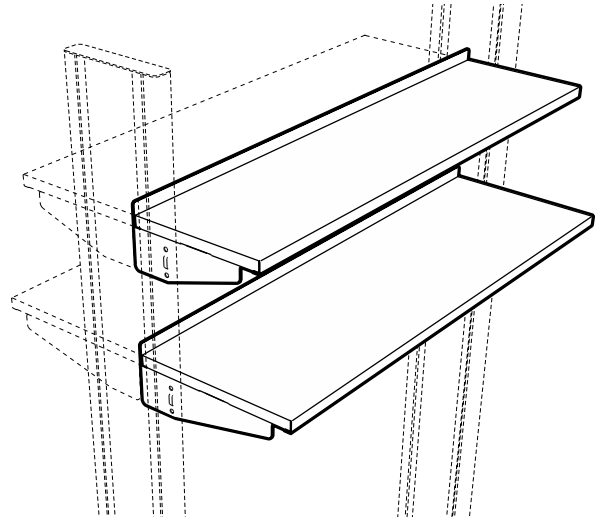

18" Deep

FV68M031824-___	24"L
FV68M031830-___	30"L
FV68M031836-___	36"L
FV68M031842-___	42"L
FV68M031848-___	48"L
FV68M031854-___	54"L
FV68M031860-___	60"L
FV68M031866-___	66"L
FV68M031872-___	72"L
FV68M031878-___	78"L
FV68M031884-___	84"L
FV68M031890-___	90"L
FV68M031896-___	96"L

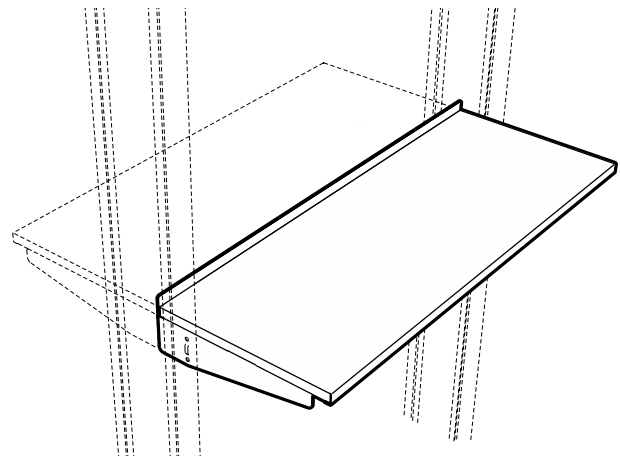

Double-sided Shelving

Double-sided Bookend Shelves consist of a pair of powder coated, 5" high, 12 gauge steel shelf brackets and a 1" thick, powder coated, 14 gauge steel shelf. Shelves are infinitely height adjustable from above the worksurface to the top of the column and have limited mounting

below worksurface. The rear edge of the shelf is centered on the workstation column and are available with or without retaining lips.

Column Depth Options:

- 09** = for 9" Deep Columns
- 12** = for 12" Deep Columns

Shelf Retaining Lip Options:

- L0** = No shelf lip
- L1** = Shelf Lip on one edge
- L2** = Shelf Lip on both edges

Example: FV64M051236-12,L2 = Shelf for 12" Column with Lip on both front and back edge.

Double-sided Bookend Shelving

12" Deep

FV64M051224-___	24"L
FV64M051230-___	30"L
FV64M051236-___	36"L
FV64M051242-___	42"L
FV64M051248-___	48"L
FV64M051254-___	54"L
FV64M051260-___	60"L
FV64M051266-___	66"L
FV64M051272-___	72"L
FV64M051278-___	78"L
FV64M051284-___	84"L
FV64M051290-___	90"L
FV64M051296-___	96"L

15" Deep

FV64M051524-___	24"L
FV64M051530-___	30"L
FV64M051536-___	36"L
FV64M051542-___	42"L
FV64M051548-___	48"L
FV64M051554-___	54"L
FV64M051560-___	60"L
FV64M051566-___	66"L
FV64M051572-___	72"L
FV64M051578-___	78"L
FV64M051584-___	84"L
FV64M051590-___	90"L
FV64M051596-___	96"L

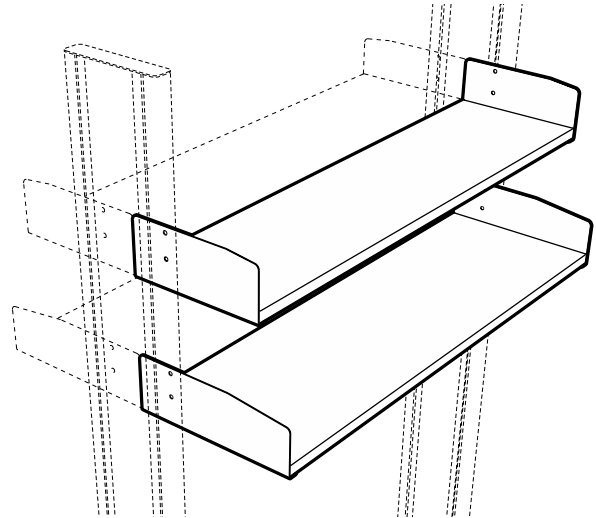

18" Deep

FV64M051824-___	24"L
FV64M051830-___	30"L
FV64M051836-___	36"L
FV64M051842-___	42"L
FV64M051848-___	48"L
FV64M051854-___	54"L
FV64M051860-___	60"L
FV64M051866-___	66"L
FV64M051872-___	72"L
FV64M051878-___	78"L
FV64M051884-___	84"L
FV64M051890-___	90"L
FV64M051896-___	96"L

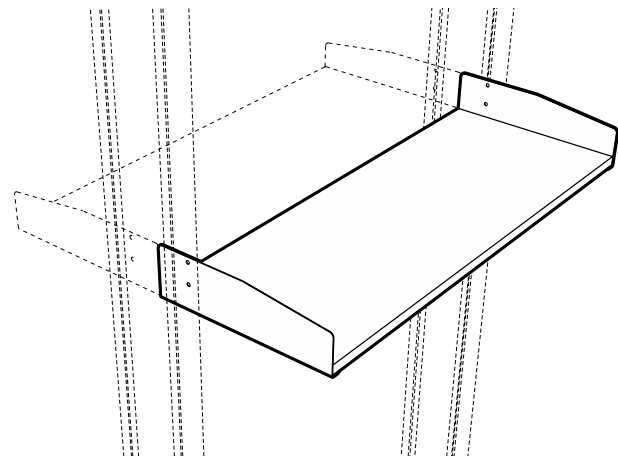

Center Shelving

Center Undermount Shelves consist of a pair of powder coated, 12 gauge steel shelf brackets and a 1" thick, powder coated, 14 gauge steel shelf. (shelf assemblies over 24" deep are furnished with two shelves) Shelves are infinitely height adjustable from above the worksurface to the top

of the column and have limited mounting below worksurface. Shelves are centered on the workstation columns and are available with or without retaining lips.

Column Depth Options:

- 09** = for 9" Deep Columns
- 12** = for 12" Deep Columns

Shelf Retaining Lip Options:

- L0** = No shelf lip
 - *L1** = Shelf Lip in center
 - L2** = Shelf Lip on both edges
 - *L3** = Shelf Lip on both edges and center
- * available only on shelves 24" deep & over
- Example: FV66M021836-09,02**
= Shelf with Lip on both edges

Center Undermount Shelving

12" Deep

FV66M021224-	24"L
FV66M021230-	30"L
FV66M021236-	36"L
FV66M021242-	42"L
FV66M021248-	48"L
FV66M021254-	54"L
FV66M021260-	60"L
FV66M021266-	66"L
FV66M021272-	72"L
FV66M021278-	78"L
FV66M021284-	84"L
FV66M021290-	90"L
FV66M021296-	96"L

18" Deep

FV66M021824-	24"L
FV66M021830-	30"L
FV66M021836-	36"L
FV66M021842-	42"L
FV66M021848-	48"L
FV66M021854-	54"L
FV66M021860-	60"L
FV66M021866-	66"L
FV66M021872-	72"L
FV66M021878-	78"L
FV66M021884-	84"L
FV66M021890-	90"L
FV66M021896-	96"L

30" Deep

FV66M033024-	24"L
FV66M033030-	30"L
FV66M033036-	36"L
FV66M033042-	42"L
FV66M033048-	48"L
FV66M033054-	54"L
FV66M033060-	60"L
FV66M033066-	66"L
FV66M033072-	72"L
FV66M033078-	78"L
FV66M033084-	84"L
FV66M033090-	90"L
FV66M033096-	96"L

15" Deep

FV66M021524-	24"L
FV66M021530-	30"L
FV66M021536-	36"L
FV66M021542-	42"L
FV66M021548-	48"L
FV66M021554-	54"L
FV66M021560-	60"L
FV66M021566-	66"L
FV66M021572-	72"L
FV66M021578-	78"L
FV66M021584-	84"L
FV66M021590-	90"L
FV66M021596-	96"L

24" Deep

FV66M032424-	24"L
FV66M032430-	30"L
FV66M032436-	36"L
FV66M032442-	42"L
FV66M032448-	48"L
FV66M032454-	54"L
FV66M032460-	60"L
FV66M032466-	66"L
FV66M032472-	72"L
FV66M032478-	78"L
FV66M032484-	84"L
FV66M032490-	90"L
FV66M032496-	96"L

36" Deep

FV66M033624-	24"L
FV66M033630-	30"L
FV66M033636-	36"L
FV66M033642-	42"L
FV66M033648-	48"L
FV66M033654-	54"L
FV66M033660-	60"L
FV66M033666-	66"L
FV66M033672-	72"L
FV66M033678-	78"L
FV66M033684-	84"L
FV66M033690-	90"L
FV66M033696-	96"L

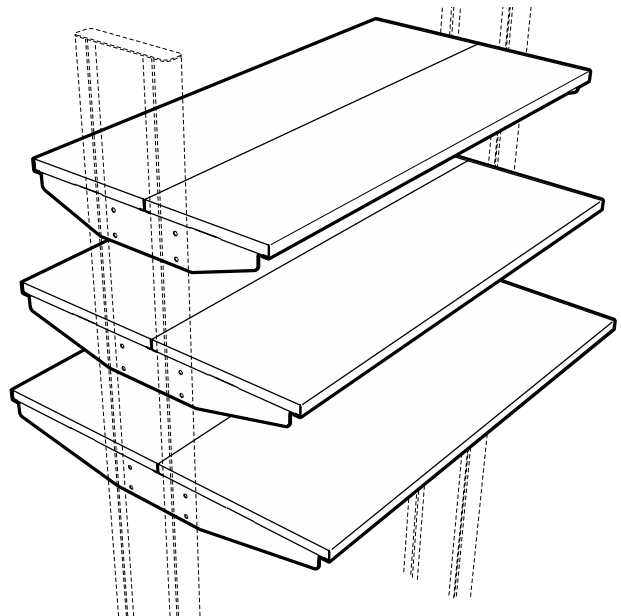
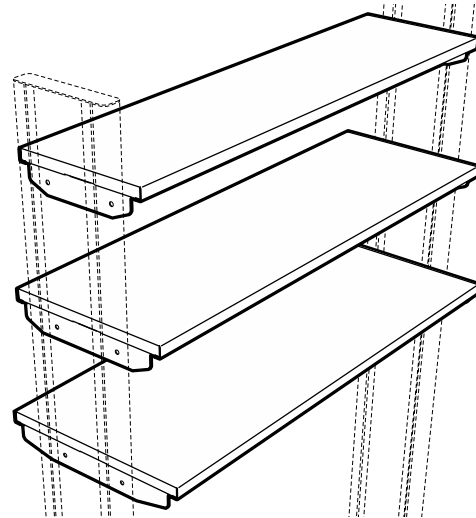

Mobile Floor Shelving

Mobile Floor Shelves are designed for heavy duty storage at the floor level. Fabricated from powder coated, 16 gauge cold rolled steel, they are mounted on four fixed casters for straight tracking, and a radius front edge with recessed handle(s).

Mobile Floor Shelving

21" Deep

FV79M042124	24"L
FV79M042130	30"L
FV79M042136	36"L
FV79M042142	42"L
FV79M042148	48"L
FV79M042154	54"L
FV79M042160	60"L
FV79M042166	66"L
FV79M042172	72"L
FV79M042178	78"L
FV79M042184	84"L
FV79M042190	90"L
FV79M042196	96"L

27" Deep

FV79M042724	24"L
FV79M042730	30"L
FV79M042736	36"L
FV79M042742	42"L
FV79M042748	48"L
FV79M042754	54"L
FV79M042760	60"L
FV79M042766	66"L
FV79M042772	72"L
FV79M042778	78"L
FV79M042784	84"L
FV79M042790	90"L
FV79M042796	96"L

33" Deep

FV79M043324	24"L
FV79M043330	30"L
FV79M043336	36"L
FV79M043342	42"L
FV79M043348	48"L
FV79M043354	54"L
FV79M043360	60"L
FV79M043366	66"L
FV79M043372	72"L
FV79M043378	78"L
FV79M043384	84"L
FV79M043390	90"L
FV79M043396	96"L

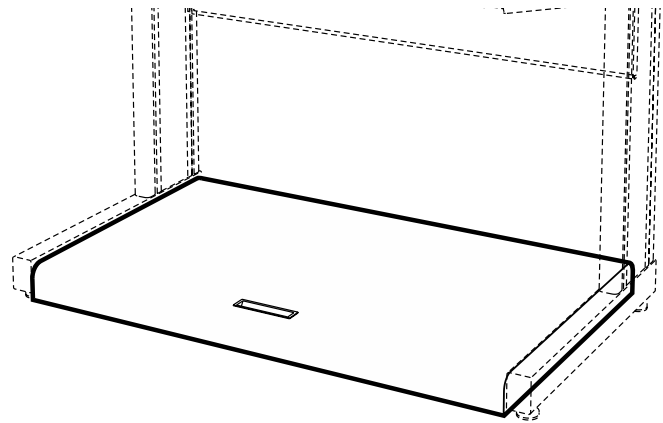

Lighting

LED Overhead Lighting mounts between the columns and includes two support arms that allows adjustment of height, tilt, and distance from column. The powder coated steel light assembly includes: LED light, On/Off switch, 24" long jumper cord, and 10 foot power cord. The light includes an easily removed diffuser and all required mounting hardware. Field installation of jumper or power cord is required.

LED Task Lighting consists of a thin-profile, white, LED strip, 9.5mm high by 33mm deep with a touch dimmer switch. It is UL listed and furnished with 120 VAC to 24 VDC power supply with ten foot power cord. The light includes a magnetic mounting strip for mounting to steel shelving and integral tabs for mounting to wood and plastic laminate.

LED Overhead Lighting

16 1/2" Long Support Arm

FV53M031624	24"L
FV53M031630	30"L
FV53M031636	36"L
FV53M031642	42"L
FV53M031648	48"L
FV53M031654	54"L
FV53M031660	60"L
FV53M031666	66"L
FV53M031672	72"L
FV53M031678	78"L
FV53M031684	84"L
FV53M031690	90"L
FV53M031696	96"L

22 1/2" Long Support Arm

FV53M032224	24"L
FV53M032230	30"L
FV53M032236	36"L
FV53M032242	42"L
FV53M032248	48"L
FV53M032254	54"L
FV53M032260	60"L
FV53M032266	66"L
FV53M032272	72"L
FV53M032278	78"L
FV53M032284	84"L
FV53M032290	90"L
FV53M032296	96"L

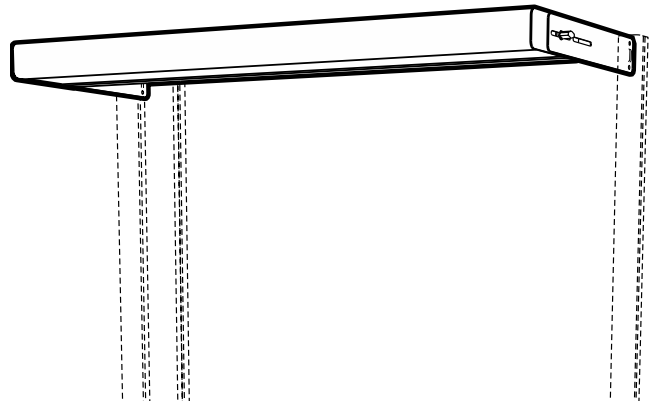

LED Task Lighting

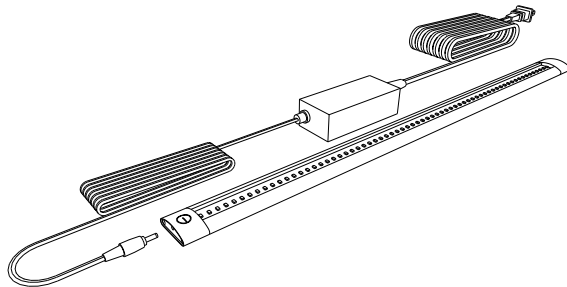

Part Number	Length	Fits Under
X-030001-00	300mm – 11 ⁷ / ₈ "	12" - 15" Shelves
X-030002-00	500mm – 19 ⁵ / ₈ "	29" - 40" Shelves
X-030003-00	1000mm – 39 ³ / ₈ "	46" - 47" Shelves

Accessories

Power Bars are available with either 15 or 20 amp black 120 VAC receptacles, include an On/Off switch with built in circuit breaker, and a black, 10 foot power cord with either a straight blade or twist-lock plug. They are column mounted and infinitely height adjustable from the worksurface to the top of the column with limited mounting ability below worksurface. Power bars are fabricated from powder coated, cold rolled steel, include all mounting hardware, and are UL Listed.

Power Cord Plug Option:

SB = Straight Blade (NEMA 5-15/5-20)
TL = Twist-lock (NEMA L5-15/L5-20)

Example: FV50M030336-A15,TL
 Power Bar with 15 amp Twist-lock plug

Power Bar

15 Amp	Number of Duplex Receptacles	
FV50M030224-A15,___	24"L	2
FV50M030230-A15,___	30"L	2
FV50M030236-A15,___	36"L	4
FV50M030242-A15,___	42"L	4
FV50M030248-A15,___	48"L	4
FV50M030254-A15,___	54"L	4
FV50M030260-A15,___	60"L	4
FV50M030266-A15,___	66"L	4
FV50M030272-A15,___	72"L	4
FV50M030278-A15,___	78"L	4
FV50M030284-A15,___	84"L	4
FV50M030290-A15,___	90"L	4
FV50M030296-A15,___	96"L	4

20 Amp	Number of Duplex Receptacles	
FV50M030224-A20,___	24"L	2
FV50M030230-A20,___	30"L	2
FV50M030236-A20,___	36"L	4
FV50M030242-A20,___	42"L	4
FV50M030248-A20,___	48"L	4
FV50M030254-A20,___	54"L	4
FV50M030260-A20,___	60"L	4
FV50M030266-A20,___	66"L	4
FV50M030272-A20,___	72"L	4
FV50M030278-A20,___	78"L	4
FV50M030284-A20,___	84"L	4
FV50M030290-A20,___	90"L	4
FV50M030296-A20,___	96"L	4

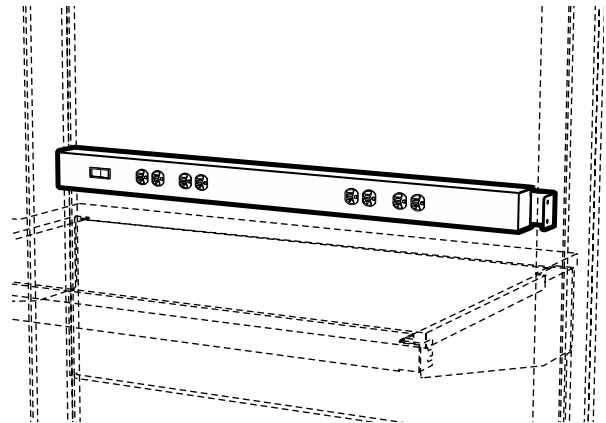

Accessories

Privacy Panels include a powder coated steel support frame, a fabric covered or magnetic marker panel, and mounting hardware. Panels are column mounted and infinitely height adjustable from above the worksurface to the top of the column. When used in conjunction with shelving, privacy panels must be mounted above the shelf or below the shelf brackets.

Material/Color Option:

- FC01** = Fabric Covered Tackboard – Almond
- FC02** = Fabric Covered Tackboard – Black
- FC03** = Fabric Covered Tackboard – Blue
- FC04** = Fabric Covered Tackboard – Grey
- FC05** = Fabric Covered Tackboard – Wineberry
- WB01** = Magnetic Marker Board – White

Example: FV73M120236-FC01

12" High x 36" Long with Almond Fabric Covered Tackboard

Privacy Panels

12" High

FV73M120224-	24"L
FV73M120230-	30"L
FV73M120236-	36"L
FV73M120242-	42"L
FV73M120248-	48"L
FV73M120254-	54"L
FV73M120260-	60"L
FV73M120266-	66"L
FV73M120272-	72"L
FV73M120278-	78"L
FV73M120284-	84"L
FV73M120290-	90"L
FV73M120296-	96"L

18" High

FV73M180224-	24"L
FV73M180230-	30"L
FV73M180236-	36"L
FV73M180242-	42"L
FV73M180248-	48"L
FV73M180254-	54"L
FV73M180260-	60"L
FV73M180266-	66"L
FV73M180272-	72"L
FV73M180278-	78"L
FV73M180284-	84"L
FV73M180290-	90"L
FV73M180296-	96"L

24" High

FV73M240224-	24"L
FV73M240230-	30"L
FV73M240236-	36"L
FV73M240242-	42"L
FV73M240248-	48"L
FV73M240254-	54"L
FV73M240260-	60"L
FV73M240266-	66"L
FV73M240272-	72"L
FV73M240278-	78"L
FV73M240284-	84"L
FV73M240290-	90"L
FV73M240296-	96"L

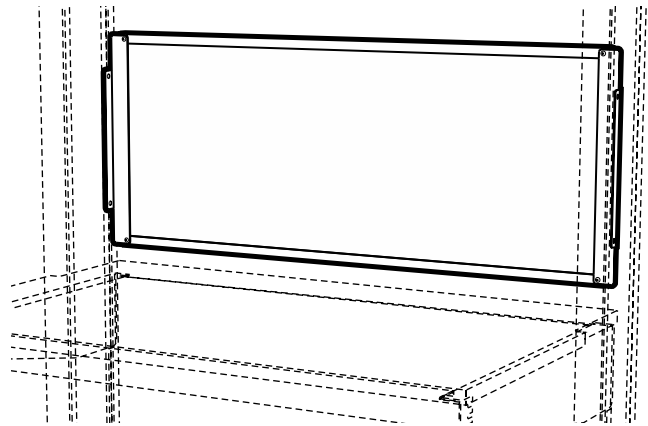

Accessories

Bin Bars are 12 gauge steel with a channel formation for added rigidity. Column mounted, infinitely height adjustable from above the worksurface to the top of the column, bin bar mounting brackets incorporate three depth adjustment slots. Bin Bars are available in either powder coated steel, or Type 304 stainless steel. Stainless Steel Bin Bars are designed for ESD applications and include a grounding kit. Both include required mounting hardware.

Bin Bars

Powder Coated Steel Bin Bar w/Brackets

FV70M020224	24"L
FV70M020230	30"L
FV70M020236	36"L
FV70M020242	42"L
FV70M020248	48"L
FV70M020254	54"L
FV70M020260	60"L
FV70M020266	66"L
FV70M020272	72"L
FV70M020278	78"L
FV70M020284	84"L
FV70M020290	90"L
FV70M020296	96"L

Stainless Steel Bin Bar w/Brackets

FV70S020224	24"L
FV70S020230	30"L
FV70S020236	36"L
FV70S020242	42"L
FV70S020248	48"L
FV70S020254	54"L
FV70S020260	60"L
FV70S020266	66"L
FV70S020272	72"L
FV70S020278	78"L
FV70S020284	84"L
FV70S020290	90"L
FV70S020296	96"L

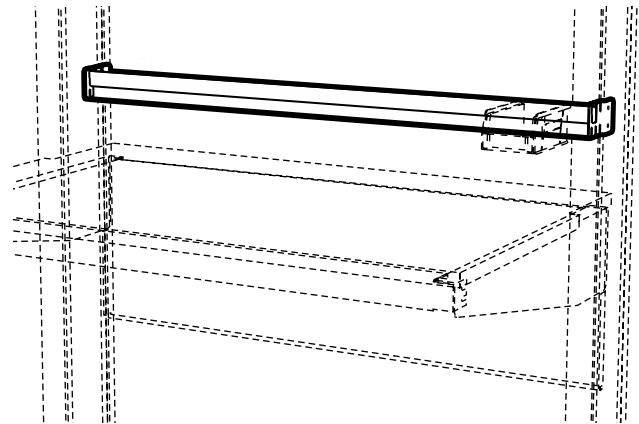

Accessories

Top of Column Horizontal Chases are designed to mount flush with the top of the column and can accommodate wiring, conduit, and piping. They provide a convenient chase for stand-alone benches or a continuous chase through the columns for interconnected applications. Made of powder coated steel, they include a removable top cover and all required mounting hardware.

Top of Column Horizontal Chase

4" High – 8" Deep

designed for 9" deep columns

FV72M040824	24"L
FV72M040830	30"L
FV72M040836	36"L
FV72M040842	42"L
FV72M040848	48"L
FV72M040854	54"L
FV72M040860	60"L
FV72M040866	66"L
FV72M040872	72"L
FV72M040878	78"L
FV72M040884	84"L
FV72M040890	90"L
FV72M040896	96"L

4" High – 11" Deep

designed for 12" deep columns

FV72M041124	24"L
FV72M041130	30"L
FV72M041136	36"L
FV72M041142	42"L
FV72M041148	48"L
FV72M041154	54"L
FV72M041160	60"L
FV72M041166	66"L
FV72M041172	72"L
FV72M041178	78"L
FV72M041184	84"L
FV72M041190	90"L
FV72M041196	96"L

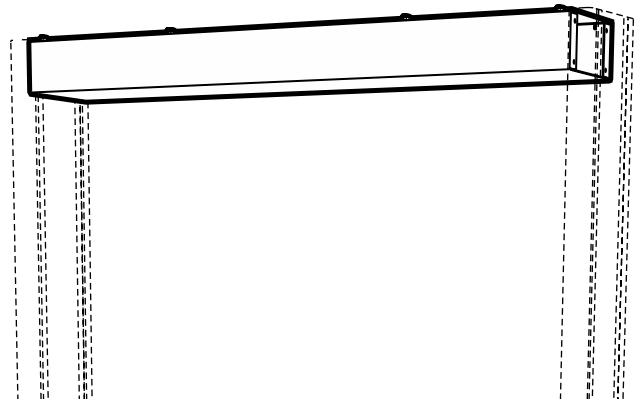

Service Fittings & Fixtures

Features:

Service Fittings

- May be mounted on columns with powder coated steel accent strips only
- Vertical columns accept up to three fittings
- Fittings pre-plumbed to hoses for connection to overhead service panels and chases
- Keyed quick-connect fittings to ease service connection and disconnection during bench relocation

Electrical and Data Fixtures

- May be mounted on columns with powder coated steel accent strips only
- May be pre-wired to top or bottom of column
- All cataloged components UL listed
- Columns are certified to UL standard 61010-1 when pre-wired with cataloged fixtures
(Because of dimensional restrictions, 24" and 30" long Single-sided Column Modules as well as all 24" deep Modules are not certified to UL Standard 61010-1. Contact Kewaunee if UL Listing is required for these sizes.)

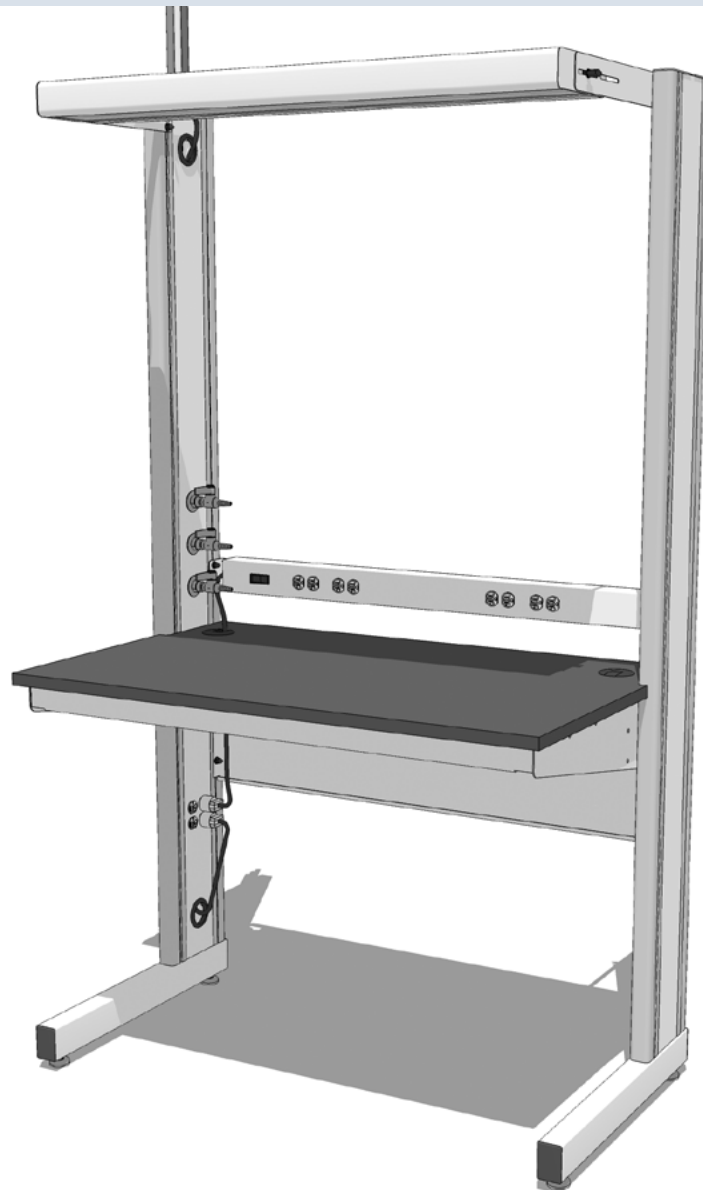

Service Fittings

Internal Service Hoses are required to mount services on the workstation columns. They are factory installed when ordered with the service fitting and are available in either reinforced PVC or braided stainless steel. The 3/8" hoses are furnished with a 3/8" IPS female outlet and either a 3/8" IPS female inlet or 3/8" IPS male quick-connect inlet.

Hoses are available in multiple lengths from 3 feet to 8 feet above the top of an 84" column and in 9 colors to match quick-connect color codes.

Specify hose color by placing color code at end of hose part number.

Example: W-6132E36-H2 for Orange hose with female inlet

Specify hose color and quick-connect key by placing color code and key number at end of hose part number.

Example: W-6135E36-H1-K4 for Black hose with Yellow Vacuum quick-connect

Service fittings require columns with steel accent strips.

Internal Service Hoses

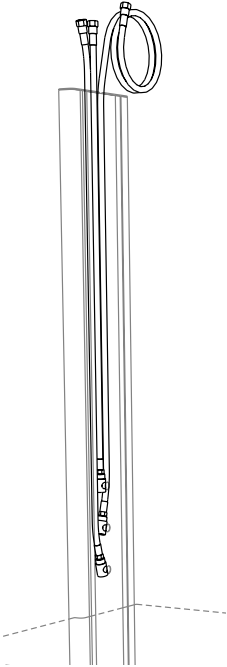

Reinforced PVC Hose

for Non-burning Gases

3/8" IPS Female Inlet – 3/8" IPS Female Outlet

Part Number	Length (Above Top Of Column)
W-6132E36-H	36" ATOC
W-6132E48-H	48" ATOC
W-6132E60-H	60" ATOC
W-6132E72-H	72" ATOC
W-6132E96-H	96" ATOC

Reinforced PVC Hose with Quick-connect Fitting

for Non-burning Gases

3/8" IPS Male Quick-connect Inlet (not illustrated)

3/8" IPS Female Outlet

Part Number	Length (Above Top Of Column)
W-6135E36-H_-K	36" ATOC
W-6135E48-H_-K	48" ATOC
W-6135E60-H_-K	60" ATOC
W-6135E72-H_-K	72" ATOC
W-6135E96-H_-K	96" ATOC

Braided Stainless Steel Hose

for Natural & Reactive Gases

3/8" IPS Female Inlet – 3/8" IPS Female Outlet

Part Number	Length (Above Top Of Column)
W-6232E36-H0	36" ATOC
W-6232E48-H0	48" ATOC
W-6232E60-H0	60" ATOC
W-6232E72-H0	72" ATOC
W-6232E96-H0	96" ATOC

Braided Stainless Steel Hose with Quick-connect Fitting

for Natural & Reactive Gases

3/8" IPS Male Quick-connect Inlet (not illustrated)

3/8" IPS Female Outlet

Part Number	Length (Above Top Of Column)
W-6235E36-K	36" ATOC
W-6235E48-K	48" ATOC
W-6235E60-K	60" ATOC
W-6235E72-K	72" ATOC
W-6235E96-K	96" ATOC

Keyed Quick-connect Fittings



Male Quick-connect

3/8" IPS Male

Part Number	Key Color
W-8111-K1	Black
W-8111-K2	Orange
W-8111-K3	Green
W-8111-K4	Yellow
W-8111-K5	Blue
W-8111-K6	White
W-8111-K7	Purple
W-8111-K8	Brown

Keyed Quick-connect Fittings

Key Number and Color Code	Standard Service	Female Body Sleeve Dia.		Male Body Sleeve Dia.	
		in.	mm	in.	mm
K1 Black	Helium	1.13	28.7	0.99	25.1
K2 Orange	Air	1.16	29.5	1.02	25.8
K3 Green	Water	1.19	30.2	1.05	26.6
K4 Yellow	Vacuum	1.22	31.0	1.08	27.4
K5 Blue	Gas	1.24	31.5	1.11	28.1
K6 White	—	1.28	32.5	1.14	28.9
K7 Purple	Argon	1.31	33.3	1.17	29.7
K8 Brown	Nitrogen	1.34	34.0	1.20	30.4

Hose Colors

Color Code	Color
H1	Black
H2	Orange
H3	Green
H4	Yellow
H5	Blue
H6	White
H7	Purple
H8	Brown
H9	Clear

Service Fittings

Ball Valves are chrome plated brass and provide on/off control of gas, air, or vacuum at pressures up to 75 PSI.

Needle Point Cocks are chrome plated brass with a nonrenewable stainless steel floating cone and a replaceable brass seat. They provide metering control of laboratory gases at pressures up to 75 PSI.

Service fittings require columns with steel accent strips.

Service Fittings

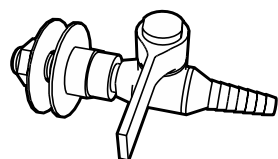

Ball Valve
3/8" IPS Male Inlet

Part Number	Service
W-0607-0A	Air
W-0607-0G	Gas
W-0607-0N	Nitrogen
W-0607-0R	Argon
W-0607-0V	Vacuum

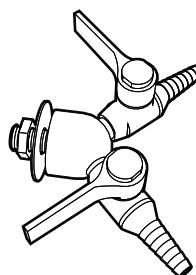

Double Ball Valve
3/8" IPS Female Inlet

Part Number	Service
W-0602-0A	Air
W-0602-0G	Gas
W-0602-0N	Nitrogen
W-0602-0R	Argon
W-0602-0V	Vacuum

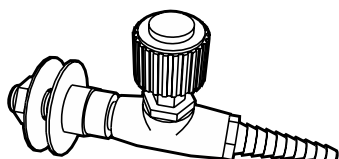

Needle Point Cock
3/8" IPS Male Inlet

Part Number	Service
W-0606-0A	Air
W-0606-0G	Gas
W-0606-0N	Nitrogen
W-0606-0R	Argon
W-0606-0V	Vacuum

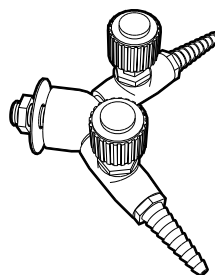

Double Needle Point Cock
3/8" IPS Female Inlet

Part Number	Service
W-0603-0A	Air
W-0603-0G	Gas
W-0603-0N	Nitrogen
W-0603-0R	Argon
W-0603-0V	Vacuum

Electric/Data Fixtures & Accessories

Electrical Fixtures may be mounted in the workstation columns as either a single device, or double device configuration. Part numbers shown include the device, the required cutout and hardware, and installation. Electrical devices include pre-wiring when a power cord is specified. Location of devices must be specified.

RJ45—8P8C Data/Com Outlets are available in either Cat-6 or Cat-6a configurations. Part numbers shown include the device, the required cutout and hardware, and installation. They do not include wiring.

Electric/Data Fixtures require columns with steel accent strips.

Electrical/Data Fixtures

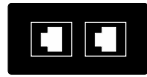
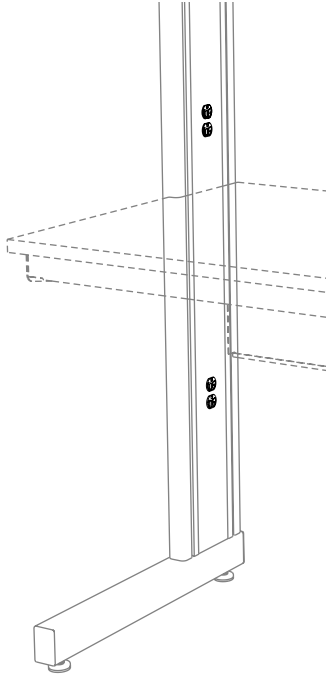

RJ45 8P8C Data/Com Outlet

Part Number	Color	Category
0720-1K-6	Black	Cat-6
0720-1V-6	Ivory	Cat-6
0720-1W-6	White	Cat-6
0720-1K-6a	Black	Cat-6a
0720-1V-6a	Ivory	Cat-6a
0720-1W-6a	White	Cat-6a

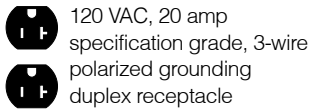
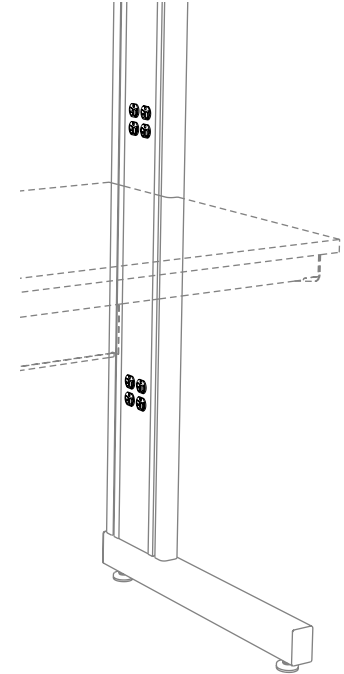

120 VAC, 20 amp specification grade, 3-wire polarized grounding duplex receptacle

Single Duplex

Part Number	Device
S581-1K	Black
S581-1V	Ivory
S581-1W	White
S581-1G	Grey
S581-1R	Red

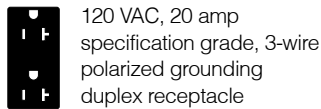

120 VAC, 20 amp specification grade, 3-wire polarized grounding duplex receptacle

Single Duplex

Part Number	Device
S681-1K	Black
S681-1V	Ivory
S681-1W	White
S681-1G	Grey
S681-1R	Red

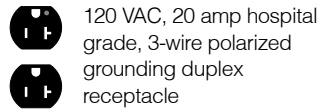

120 VAC, 20 amp hospital grade, 3-wire polarized grounding duplex receptacle

Hospital Grade Single Duplex

Part Number	Device
H581-1K	Black
H581-1V	Ivory
H581-1W	White
H581-1G	Grey
H581-1R	Red

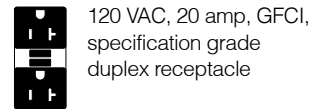

120 VAC, 20 amp, GFCI, specification grade duplex receptacle

GFCI Single Duplex

Part Number	Device
S656-1K	Black
S656-1V	Ivory
S656-1W	White
S656-1G	Grey
S656-1R	Red

Electric/Data Fixtures & Accessories

Power Cords are required to carry power from the electrical devices to wall outlets or overhead service panels. The SJ 12/3 and SJ 12/4 cords are available in multiple lengths measured from the top of 84" high columns. Standard exit point is the top of the column, but they may be routed to the bottom when specified.

Cord Access Ports are designed to route power and data cords from the interior of the column through the column accent strip, but may be used as pass-thru ports when workstations are set in a continuous run. Ports are a 2 1/2" diameter hole fitted with a rubber grommet creating a 2 1/8" diameter access. Location of ports must be specified.

Power Cords

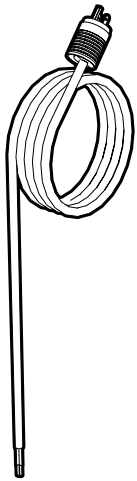

Single-circuit 3-wire

120 VAC — 20A — NEMA 5-20

Part Number	Length	Plug Type
W-5621-36	36" ATOC	Straight Blade
W-5621-48	48" ATOC	Straight Blade
W-5621-60	60" ATOC	Straight Blade
W-5621-72	72" ATOC	Straight Blade
W-5621-96	96" ATOC	Straight Blade

120 VAC — 20A — NEMA L5-20

Part Number	Length	Plug Type
W-5622-36	36" ATOC	Twist-Lock
W-5622-48	48" ATOC	Twist-Lock
W-5622-60	60" ATOC	Twist-Lock
W-5622-72	72" ATOC	Twist-Lock
W-5622-96	96" ATOC	Twist-Lock

Dual-circuit 4-wire

120 VAC — 20A — NEMA L14-20

Part Number	Length	Plug Type
W-5624-36	36" ATOC	Twist-Lock
W-5624-48	48" ATOC	Twist-Lock
W-5624-60	60" ATOC	Twist-Lock
W-5624-72	72" ATOC	Twist-Lock
W-5624-96	96" ATOC	Twist-Lock

Cord Access Ports

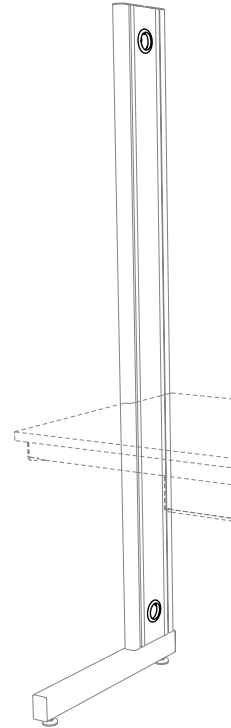

Part Number _____

F-8421-00

Steel & Wood Cabinets

Features:

Steel Base Cabinets

- Electrostatically applied, chemical resistant, powder coat finish available in colors to compliment any laboratory environment
- Heavy gauge formed and welded steel cabinet body construction provides strength and durability
- One piece drawer body, radiused all four sides
- Furnished standard with full-extension, soft-close drawer slides
- One-piece case bottom and horizontal front rail
- Furnished standard with finished back
- Exclusive positive door catch option
- Five-knuckle, semi-concealed, and concealed hinges available

Wood Base Cabinets

- Multiple coat, chemical resistant finish system formulated to highlight the natural grain patterns
- Dovetailed drawer construction with nine-ply hardwood plywood drawer sides
- 3/4" seven-ply hardwood plywood end panels, bottom and shelf, with solid hardwood facing
- Full extension, ball bearing, 100 lb. load rated, drawer slides, standard on all drawers and pullboards.
- 3/4" seven-ply hardwood plywood finished back dadoed into end panels and bottom
- Institutional type five-knuckle offset door hinges rated for 150 pound loads



Cabinet Door & Drawer Styles

Steel Inset — Square Edge

- Doors and drawer heads are flush with face of cabinet
- Square Edge
- Multiple Pull and Hinge Options



with Type 1 Pull



with Type 9 Pull

Wood Style-1



Conventional

- Radius Lip, Semi-Overlay Construction
- Multiple Pull Options

Steel Overlay — Square Edge

- Square Edge Full Overlay Construction
- Multiple Pull and Hinge Options



with Type 8 Pull



with Type 9 Pull

Wood Style-5



Contemporary

- Square Edge, Full Overlay Construction
- Multiple Pull Options

Steel Overlay — Bevel Edge

- Beveled Edge Full Overlay Construction
- Multiple Pull and Hinge Options



with Type 4 Pull



with Type 9 Pull

Steel Overlay — Wood on Steel

- Oak or Maple Door and Drawer Front
- Multiple Pull and Hinge Options



Steel and Wood Cabinet Part Numbers

Base Cabinet Catalog Number Explanation

M 25 C 33 22 18 - 10 11

<p>Cabinet Type</p> <p>B = Open Cupboard Cabinet C = All Cupboard Cabinet D = All Drawer Cabinet E = Drawer & Cupboard Cabinet G = Special Purpose Cabinet M = Mobile Cabinet</p> <p>Drawer and Door Configuration</p> <p>Cabinetry Material</p> <p>W = Wood C = Steel</p>	<p style="text-align: center;">M 25 C 33 22 18 - 10 11</p>	<p>Style-Hardware Material Selection</p> <p>See Below</p> <p>Special Configurations</p> <p>L = Left Hand Swing</p> <p>Cabinet Length</p> <p>(Nominal in Inches)</p> <p>Cabinet Depth</p> <p>(Nominal in Inches)</p> <p>Cabinet Height</p> <p>19 = 19³/₈" 20 = 19⁵/₈" 25 = 25¹/₈" 26 = 25¹⁵/₁₆" 26 = 26¹/₄" 27 = 26³/₄" 33 = 33"</p>
-------------------------------------------------------------------------------------------------------------------------------------------------------------------------------------------------------------------------------------------------------------------------------------------------------------------------------------------------------------------------------------------	-------------------------------------------------------------------	----------------------------------------------------------------------------------------------------------------------------------------------------------------------------------------------------------------------------------------------------------------------------------------------------------------------------------------------------------------------------------------------------------------------------------------------------------------------------------------------------------------------------------------------------------------------------------------

Steel Furniture Style - Hardware - Material Selections

M 25 C 33 22 18 - 0 1 0 1

<p>Cabinet Style - Hinge Type - Catch</p> <p>0 = Inset - 5-knuckle Hinge - Positive Catch 1 = Full Overlay - 5-knuckle Hinge - Positive Catch 4 = Full Overlay - Semi-concealed Hinge 6 = Full Overlay - Concealed Hinge (170° Swing)</p> <p>Door and Drawer Style</p> <p>1 = Square Edge Steel 6 = Wood - Available for Full Overlay Cabinet Styles only 7 = Beveled Edge Steel - Available for Full Overlay Cabinet Styles only</p> <p>Cabinet Material / D&D Material</p> <p>0 = Cold Rolled Steel / Cold Rolled Steel *3 = Stainless Steel / Stainless Steel 1 = Cold Rolled Steel / Plain Sliced Red Oak 5 = Cold Rolled Steel / FSC® Red Oak 2 = Cold Rolled Steel / Plain Sliced White Maple 6 = Cold Rolled Steel / FSC® White Maple 7 = Cold Rolled Steel / Steamed Beech 8 = Cold Rolled Steel / FSC® Steamed Beech</p> <p><small>* Stainless Steel available in D&D Style 1 only</small></p>	<p>Pull Type</p> <p>0 = No Option 1 = Rounded Aluminum 2 = Black Wire 3 = White Wire 4 = Stainless Steel Wire 6 = Chrome Plated Wire ‡7 = Beveled Label Holder 8 = Square Aluminum †9 = Flush Aluminum ‡ Mounts horizontally † Not available on wood doors & drawer heads</p>
---------------------------------------------------------------------------------------------------------------------------------------------------------------------------------------------------------------------------------------------------------------------------------------------------------------------------------------------------------------------------------------------------------------------------------------------------------------------------------------------------------------------------------------------------------------------------------------------------------------------------------------------------------------------------------------------------------------------------------------------------------------------------------------------------------------------------------------------------------------------------------------------------------------------------------------------------------------------------------------------------------------------------------------------------------------------------------------------------	-----------------------------------------------------------------------------------------------------------------------------------------------------------------------------------------------------------------------------------------------------------------------------------------------------------------------------------------------------------------------------------------------------------

Wood Furniture Style - Hardware - Material Selections

M 25 W 33 22 18 - 10 11

<p>Door and Drawer Head Style</p> <p>0 = No Option 1 = Conventional Radius Lip 3 = Silhouette 5 = Contemporary Full Overlay</p> <p>Hinge Type</p> <p>0 = Stainless Steel - Five Knuckle 2 = Black Powder Coated - Five Knuckle 3 = White Powder Coated - Five Knuckle</p> <p>Cabinet Exterior</p> <p>1 = Plain Sliced Red Oak 2 = Plain Sliced White Maple - available for Style 1 Style 5 only 5 = FSC/NAF Red Oak 6 = FSC/NAF White Maple - available for Style 1 Style 5 only 7 = Steamed Beech 8 = FSC/NAF Steamed Beech - available for Style 1 Style 5 only</p>	<p>Pull Type</p> <p>*0 = No Pull 1 = Rounded Aluminum 2 = Black Wire 3 = White Wire 4 = Stainless Steel Wire 5 = Integral Machined 6 = Chrome Plated Wire ‡7 = Beveled Label Holder 8 = Square Aluminum ‡ Mounts horizontally * pull holes bored on 4" centers but no pull provided</p>
-----------------------------------------------------------------------------------------------------------------------------------------------------------------------------------------------------------------------------------------------------------------------------------------------------------------------------------------------------------------------------------------------------------------------------------------------------------------------------------------------------------------------------------------------------------------------------------------------------------------------------------------------------------------------------------------------------------------------------------------	-----------------------------------------------------------------------------------------------------------------------------------------------------------------------------------------------------------------------------------------------------------------------------------------------------------------------------------------------------------------------------------------------------------------

Base Cabinet Information

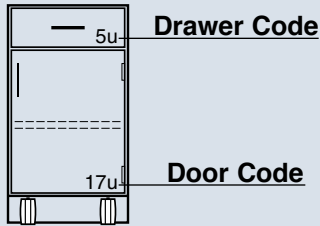

Base cabinets are designed on a "unit" system to allow maximum flexibility in the selection of drawer and/or cupboard door sizes. The charts below show both the actual height as well as the "unit" height of both Steel and Wood Base Cabinets

The adjacent tables indicate the "unit" height, actual height and inside clearance dimensions of the base cabinets drawers and cupboards. Simply match the "unit" code shown on the cabinet to the appropriate code in the tables.

Steel Cabinet Dimensions		
Descriptive Height	Dimensional Height	Unit Height
Standing Mobile	33"	54 units
Sitting Mobile	26 ¹ / ₄ "	42 units
25" High Suspended	25 ¹ / ₈ "	48 units
19" High Suspended	19 ³ / ₈ "	36 units

Wood Cabinet Dimensions		
Descriptive Height	Dimensional Height	Unit Height
Standing Mobile	33"	22 units
Sitting Mobile	26 ³ / ₄ "	17 units
25" High Suspended	25 ¹⁵ / ₁₆ "	20 units
19" High Suspended	19 ⁵ / ₈ "	15 units

Steel Drawer Size Codes

Units High	Drawer Head Height	Inside Dimensions	
		Clear/Height	Length (Front-to-Back)
8	3 ³ / ₄ "	2 ³ / ₈ "	18"
9	4 ¹ / ₄ "	2 ³ / ₈ "	18"
10	4 ³ / ₄ "	3 ⁷ / ₁₆ "	18"
11	5 ³ / ₁₆ "	3 ¹⁵ / ₁₆ "	18"
12	5 ¹¹ / ₁₆ "	4 ⁷ / ₁₆ "	18"
14	6 ⁵ / ₈ "	5 ³ / ₈ "	18"
15	6 ¹ / ₈ "	5 ⁷ / ₈ "	18"
16	7 ⁵ / ₈ "	6 ³ / ₈ "	18"
20	9 ⁹ / ₁₆ "	8 ⁵ / ₁₆ "	18"
24	11 ¹ / ₂ "	10 ¹ / ₄ "	18"
3	1 ³ / ₁₆ "	Pullout Shelf	

Steel Drawer Width I.D. (side-to-side)

Base Cabinet Length	Number of Drawers Across		
	1	2	3
12"	8 ³ / ₈ "		
15"	11 ³ / ₈ "		
18"	14 ³ / ₈ "		
21"	17 ³ / ₈ "		
24"	20 ³ / ₈ "	8 ³ / ₈ "	
30"	26 ³ / ₈ "	11 ³ / ₈ "	
36"	32 ³ / ₈ "	14 ³ / ₈ "	8 ³ / ₈ "
42"	38 ³ / ₈ "	17 ³ / ₈ "	
48"	44 ³ / ₈ "	20 ³ / ₈ "	12 ³ / ₈ "

Steel Cupboard Size Codes

Units High	Door Height	Inside Dimensions	
		Height (Top-to-Bottom)	Depth (Front-to-Back)
30	14 ⁹ / ₁₆ "	13 ⁹ / ₁₆ "	20 ¹ / ₂ "
36	17 ⁷ / ₁₆ "	16 ⁷ / ₁₆ "	20 ¹ / ₂ "
45	21 ¹³ / ₁₆ "	20 ¹³ / ₁₆ "	20 ¹ / ₂ "
48	23 ³ / ₁₆ "	22 ³ / ₁₆ "	20 ¹ / ₂ "
54	26 ¹ / ₁₆ "	25 ¹ / ₁₆ "	20 ¹ / ₂ "
60	29"	28"	20 ¹ / ₂ "

Steel Cupboard Width I.D. (side-to-side)

Base Cabinet Length	Number of Cupboards Across		
	1	2	3
12"	9 ¹ / ₂ "		
15"	12 ¹ / ₂ "		
18"	15 ¹ / ₂ "		
21"	18 ¹ / ₂ "		
24"	21 ¹ / ₂ "	9 ¹ / ₂ "	
30"	27 ¹ / ₂ "	12 ¹ / ₂ "	
36"	33 ¹ / ₂ "	15 ¹ / ₂ "	9 ¹ / ₂ "
42"	39 ¹ / ₂ "	18 ¹ / ₂ "	
48"	45 ¹ / ₂ "	21 ¹ / ₂ "	13 ¹ / ₂ "

Wood Drawer Size Codes

Units High	Drawer Head Height	Inside Dimensions	
		Clear/Height	Length (Front-to-Back)
2	Pullboard		14"
3	2 ¹³ / ₁₆ "	2 ¹ / ₈ " †	16 ³ / ₄ "
4	4 ¹ / ₁₆ "	3 ³ / ₈ " †	16 ³ / ₄ "
5	5 ⁵ / ₁₆ "	4 ⁵ / ₈ " †	16 ³ / ₄ "
6	6 ⁹ / ₁₆ "	5 ⁷ / ₈ " †	16 ³ / ₄ "
7	7 ¹³ / ₁₆ "	7 ¹ / ₈ " †	16 ³ / ₄ "
8	9 ¹ / ₈ "	8 ³ / ₈ " †	16 ³ / ₄ "
10	11 ⁵ / ₈ "	10 ⁷ / ₈ " †	16 ³ / ₄ "
12	14 ¹ / ₈ "	13 ¹ / ₈ " †	16 ³ / ₄ "

† 1/4" less if drawer is top drawer in cabinet

Wood Drawer Width I.D. (side-to-side)

Base Cabinet Length	Number of Drawers Across		
	1	2	3
15"	11 ¹ / ₂ "		
18"	14 ¹ / ₂ "		
21"	17 ¹ / ₂ "		
24"	20 ¹ / ₂ "	8 ³ / ₄ "	
30"	26 ¹ / ₂ "	11 ³ / ₄ "	
36"	32 ¹ / ₂ "	14 ³ / ₄ "	8 ³ / ₄ "
42"	38 ¹ / ₂ "	17 ³ / ₄ "	11 ³ / ₄ "
48"	44 ¹ / ₂ "	20 ³ / ₄ "	14 ³ / ₄ "

Wood Cupboard Size Codes

Units High	Opening Height	Inside Dimensions	
		Height (Top-to-Bottom)	Depth (Front-to-Back)
12	14 ³ / ₈ "	14 ³ / ₈ "	19 ¹ / ₂ "
15	18 ¹ / ₈ "	18 ¹ / ₈ "	19 ¹ / ₂ "
16	19 ³ / ₈ "	19 ³ / ₈ "	19 ¹ / ₂ "
17	20 ⁵ / ₈ "	20 ⁵ / ₈ "	19 ¹ / ₂ "
18	21 ⁷ / ₈ "	21 ⁷ / ₈ "	19 ¹ / ₂ "
20	24 ¹ / ₄ "	24 ¹ / ₄ "	19 ¹ / ₂ "
22	26 ³ / ₄ "	26 ³ / ₄ "	19 ¹ / ₂ "
24	29 ¹ / ₄ "	29 ¹ / ₄ "	19 ¹ / ₂ "

Wood Cupboard Width I.D. (side-to-side)

Base Cabinet Length	Number of Cupboards Across		
	1	2	3
15"	13 ¹ / ₂ "		
18"	16 ¹ / ₂ "		
21"	19 ¹ / ₂ "		
24"	22 ¹ / ₂ "	10 ³ / ₄ "	
30"	28 ¹ / ₂ "	13 ³ / ₄ "	
36"	34 ¹ / ₂ "	16 ³ / ₄ "	10 ³ / ₄ "
42"	40 ¹ / ₂ "	19 ³ / ₄ "	12 ³ / ₄ "
48"	46 ¹ / ₂ "	22 ³ / ₄ "	14 ³ / ₄ "

The dimensions shown in these tables are minimums. They may be slightly larger on some cabinet types and/or styles .

Wood Sitting Height Mobile Cabinets

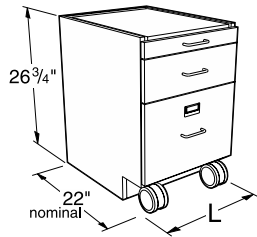

Specifications:

These Mobile Cabinets are 26³/₄" high and a nominal 22" deep. Lengths as shown. They are designed to fit under sitting height worksurface frames.

Drawer cabinets are furnished with counter weights, multiple-drawer cabinets include an interlock system. All mobile cabinets have finished backs.

Note: Last four digits of part number designates door and drawer head style, hinge, hardwood species, and pull selection. See page 38 for full explanation. Actual product may vary slightly from catalog illustration due to style and hardware selection.

Cupboard Cabinets

Cupboard Cabinets with Pullboards

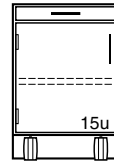
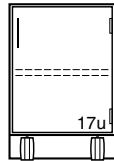
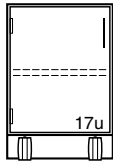

M10W272215L _____ 15"L
M10W272218L _____ 18"L
M10W272221L _____ 21"L
M10W272224L _____ 24"L

M10W272215- _____ 15"L
M10W272218- _____ 18"L
M10W272221- _____ 21"L
M10W272224- _____ 24"L

M15W272215L _____ 15"L
M15W272218L _____ 18"L
M15W272221L _____ 21"L
M15W272224L _____ 24"L

M15W272215- _____ 15"L
M15W272218- _____ 18"L
M15W272221- _____ 21"L
M15W272224- _____ 24"L

Drawer/Cupboard Cabinets

Drawer/Cupboard Cabinets with Pullboards

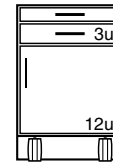
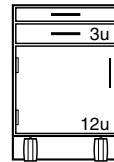
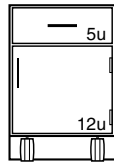
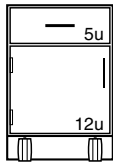

M20W272215L _____ 15"L
M20W272218L _____ 18"L
M20W272221L _____ 21"L
M20W272224L _____ 24"L

M20W272215- _____ 15"L
M20W272218- _____ 18"L
M20W272221- _____ 21"L
M20W272224- _____ 24"L

M25W272215L _____ 15"L
M25W272218L _____ 18"L
M25W272221L _____ 21"L
M25W272224L _____ 24"L

M25W272215- _____ 15"L
M25W272218- _____ 18"L
M25W272221- _____ 21"L
M25W272224- _____ 24"L

Drawer Cabinets

Drawer Cabinets with Pullboards

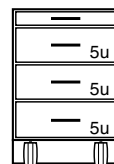
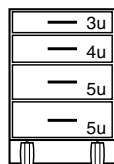
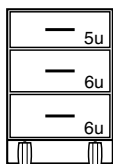

M30W272215- _____ 15"L
M30W272218- _____ 18"L
M30W272221- _____ 21"L
M30W272224- _____ 24"L

M40W272215- _____ 15"L
M40W272218- _____ 18"L
M40W272221- _____ 21"L
M40W272224- _____ 24"L

M35W272215- _____ 15"L
M35W272218- _____ 18"L
M35W272221- _____ 21"L
M35W272224- _____ 24"L

Note: Wood Mobile Cabinets are constructed with finished top panels. Tops may be added but are not required to close the top of the cabinet.

Tops are recommended on wood mobile cabinets with pullboards.

Tops must be ordered separately. (see page 45)

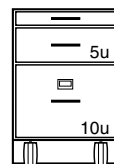
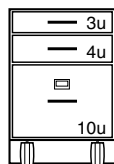
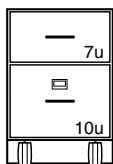

M60W272215- _____ 15"L
M60W272218- _____ 18"L
M60W272221- _____ 21"L
M60W272224- _____ 24"L

M62W272215- _____ 15"L
M62W272218- _____ 18"L
M62W272221- _____ 21"L
M62W272224- _____ 24"L

M65W272215- _____ 15"L
M65W272218- _____ 18"L
M65W272221- _____ 21"L
M65W272224- _____ 24"L

Wood Standing Height Mobile Cabinets

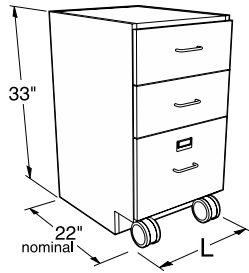

Specifications:

These Mobile Cabinets are 33" high and a nominal 22" deep. Lengths as shown. They are designed to fit under standing height worksurface frames.

Drawer cabinets are furnished with counter weights, multiple-drawer cabinets include an interlock system. All mobile cabinets have finished backs.

Note: Last four digits of part number designates door and drawer head style, hinge, hardwood species, and pull selection. See page 38 for full explanation. Actual product may vary slightly from catalog illustration due to style and hardware selection.

Cupboard Cabinets

Cupboard Cabinets with Pullboards

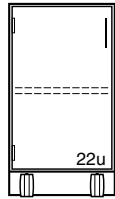

- M10W332215L _____ 15"L
- M10W332218L _____ 18"L
- M10W332221L _____ 21"L
- M10W332224L _____ 24"L

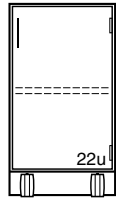

- M10W332215- _____ 15"L
- M10W332218- _____ 18"L
- M10W332221- _____ 21"L
- M10W332224- _____ 24"L

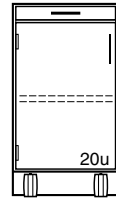

- M15W332215L _____ 15"L
- M15W332218L _____ 18"L
- M15W332221L _____ 21"L
- M15W332224L _____ 24"L



- M15W332215- _____ 15"L
- M15W332218- _____ 18"L
- M15W332221- _____ 21"L
- M15W332224- _____ 24"L

Drawer/Cupboard Cabinets

Drawer/Cupboard Cabinets with Pullboards

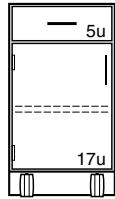

- M20W332215L _____ 15"L
- M20W332218L _____ 18"L
- M20W332221L _____ 21"L
- M20W332224L _____ 24"L

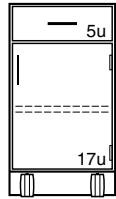

- M20W332215- _____ 15"L
- M20W332218- _____ 18"L
- M20W332221- _____ 21"L
- M20W332224- _____ 24"L

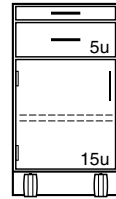

- M25W332215L _____ 15"L
- M25W332218L _____ 18"L
- M25W332221L _____ 21"L
- M25W332224L _____ 24"L

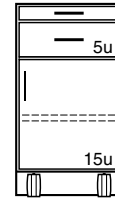

- M25W332215- _____ 15"L
- M25W332218- _____ 18"L
- M25W332221- _____ 21"L
- M25W332224- _____ 24"L

Drawer Cabinets

Drawer Cabinets with Pullboards

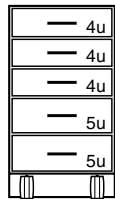

- M50W332215- _____ 15"L
- M50W332218- _____ 18"L
- M50W332221- _____ 21"L
- M50W332224- _____ 24"L

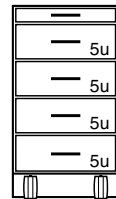

- M45W332215- _____ 15"L
- M45W332218- _____ 18"L
- M45W332221- _____ 21"L
- M45W332224- _____ 24"L

Note: Wood Mobile Cabinets are constructed with finished top panels. Tops may be added but are not required to close the top of the cabinet.

Tops are recommended on wood mobile cabinets with pullboards.

Tops must be ordered separately. (see page 45)

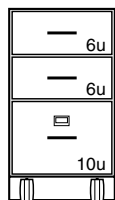

- M62W332215- _____ 15"L
- M62W332218- _____ 18"L
- M62W332221- _____ 21"L
- M62W332224- _____ 24"L

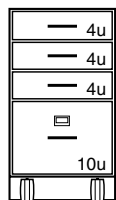

- M63W332215- _____ 15"L
- M63W332218- _____ 18"L
- M63W332221- _____ 21"L
- M63W332224- _____ 24"L

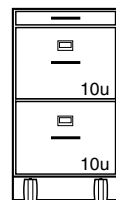

- M75W332215- _____ 15"L
- M75W332218- _____ 18"L
- M75W332221- _____ 21"L
- M75W332224- _____ 24"L

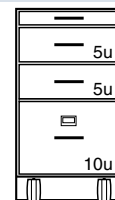

- M67W332215- _____ 15"L
- M67W332218- _____ 18"L
- M67W332221- _____ 21"L
- M67W332224- _____ 24"L

Steel Sitting Height Mobile Cabinets

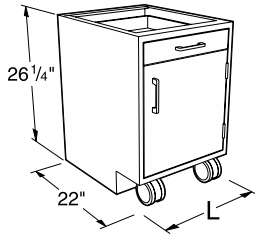

Specifications

These Mobile Cabinets are 26 1/4" high and 22" deep. Lengths as shown. They are designed to fit under sitting height workstation frames.

Drawer cabinets are furnished with counter weights, multiple-drawer cabinets include an interlock system. All mobile cabinets have finished backs.

Note: Last four digits of part number designates door and drawer head style, hinge, hardwood species and pull selection. See page 38 for full explanation. Actual product may vary slightly from catalog illustration due to style and hardware selection.

Cupboard Cabinets

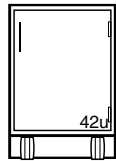
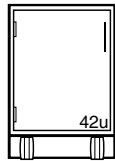

M10C262215L	15"L	M10C262215-	15"L
M10C262218L	18"L	M10C262218-	18"L
M10C262221L	21"L	M10C262221-	21"L
M10C262224L	24"L	M10C262224-	24"L

Note: Steel Mobile Cabinets are constructed with open top frames. Tops are required to close the top of the cabinets.

Tops must be ordered separately.
(see page 45)

Drawer/Cupboard Cabinets

Drawer/Cupboard Cabinets with Pullboards

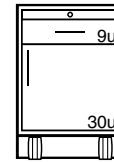
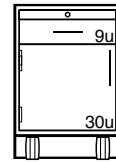
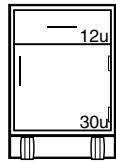
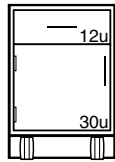

M20C262215L	15"L	M20C262215-	15"L
M20C262218L	18"L	M20C262218-	18"L
M20C262221L	21"L	M20C262221-	21"L
M20C262224L	24"L	M20C262224-	24"L

M25C262215L	15"L	M25C262215-	15"L
M25C262218L	18"L	M25C262218-	18"L
M25C262221L	21"L	M25C262221-	21"L
M25C262224L	24"L	M25C262224-	24"L

Drawer Cabinets

Drawer Cabinets with Pullboards

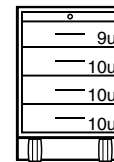
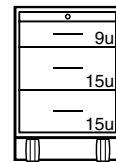
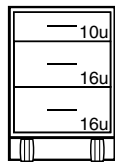

M30C262215-	15"L
M30C262218-	18"L
M30C262221-	21"L
M30C262224-	24"L

M35C262215-	15"L
M35C262218-	18"L
M35C262221-	21"L
M35C262224-	24"L

M45C262215-	15"L
M45C262218-	18"L
M45C262221-	21"L
M45C262224-	24"L

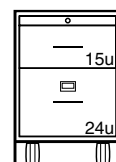
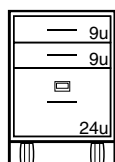

M62C262215-	15"L
M62C262218-	18"L
M62C262221-	21"L
M62C262224-	24"L

M66C262215-	15"L
M66C262218-	18"L
M66C262221-	21"L
M66C262224-	24"L

Steel Standing Height Mobile Cabinets

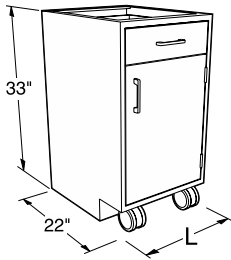

Specifications

These Mobile Cabinets are 33" high and 22" deep. Lengths as shown. They are designed to fit under standing height workstation frames.

Drawer cabinets are furnished with counter weights, multiple-drawer cabinets include an interlock system. All mobile cabinets have finished backs.

Note: Last four digits of part number designates door and drawer head style, hinge, hardwood species and pull selection. See page 38 for full explanation. Actual product may vary slightly from catalog illustration due to style and hardware selection.

Cupboard Cabinets

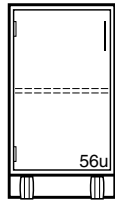

- M10C332215L _____ 15"L
- M10C332218L _____ 18"L
- M10C332221L _____ 21"L
- M10C332224L _____ 24"L

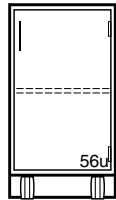

- M10C332215- _____ 15"L
- M10C332218- _____ 18"L
- M10C332221- _____ 21"L
- M10C332224- _____ 24"L

Note: Steel Mobile Cabinets are constructed with open top frames. Tops are required to close the top of the cabinets.

Tops must be ordered separately.
(see page 45)

Drawer/Cupboard Cabinets

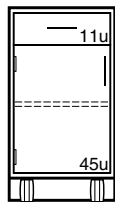

- M20C332215L _____ 15"L
- M20C332218L _____ 18"L
- M20C332221L _____ 21"L
- M20C332224L _____ 24"L

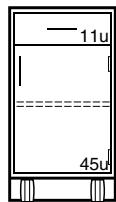

- M20C332215- _____ 15"L
- M20C332218- _____ 18"L
- M20C332221- _____ 21"L
- M20C332224- _____ 24"L

Drawer/Cupboard Cabinets with Pullboards

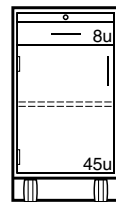

- M25C332215L _____ 15"L
- M25C332218L _____ 18"L
- M25C332221L _____ 21"L
- M25C332224L _____ 24"L



- M25C332215- _____ 15"L
- M25C332218- _____ 18"L
- M25C332221- _____ 21"L
- M25C332224- _____ 24"L

Drawer Cabinets

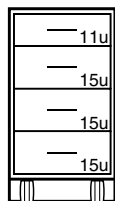

- M40C332215- _____ 15"L
- M40C332218- _____ 18"L
- M40C332221- _____ 21"L
- M40C332224- _____ 24"L

Drawer Cabinets with Pullboards

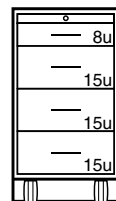

- M46C332215- _____ 15"L
- M46C332218- _____ 18"L
- M46C332221- _____ 21"L
- M46C332224- _____ 24"L

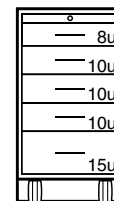

- M56C332215- _____ 15"L
- M56C332218- _____ 18"L
- M56C332221- _____ 21"L
- M56C332224- _____ 24"L

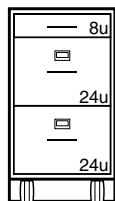

- M71C332215- _____ 15"L
- M71C332218- _____ 18"L
- M71C332221- _____ 21"L
- M71C332224- _____ 24"L

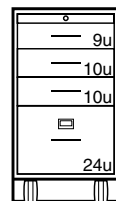

- M68C332215- _____ 15"L
- M68C332218- _____ 18"L
- M68C332221- _____ 21"L
- M68C332224- _____ 24"L

Illustrations and specifications are based on most current design and production information available. Kewaunee reserves the right to make changes at any time without notice.

Add-A-Drawer Mobile Cabinets

Specifications:

Add-A-Drawer Mobile Cabinets allow the removal of the top drawer assembly to convert the cabinet from standing height to sitting height. The base section of the add-a-drawer cabinet is 26³/₄" high, the add-on drawer 6¹/₄", for an overall height of 33".

All add-a-drawer mobile cabinets have finished backs and counter-weights. The M95 four-drawer cabinet incorporates a drawer interlock system on the bottom three drawers.

The cabinets are a nominal 22" deep with lengths as shown. They are designed to fit under 30" and 36" high worksurface frames.

Cupboards have one adjustable shelf.

Tops of both the base section and the add-on drawer are finished to match the cabinet.

Note: Last four digits of part number designates door and drawer head style, hinge, hardwood species, and pull selection. See page 38 for full explanation. Actual product may vary slightly from catalog illustration due to style and hardware selection.

Tops may be added but are not required for a finished cabinet.

When desired, tops must be ordered separately. (see page 55)

Wood Add-A-Drawer Mobile Cabinets

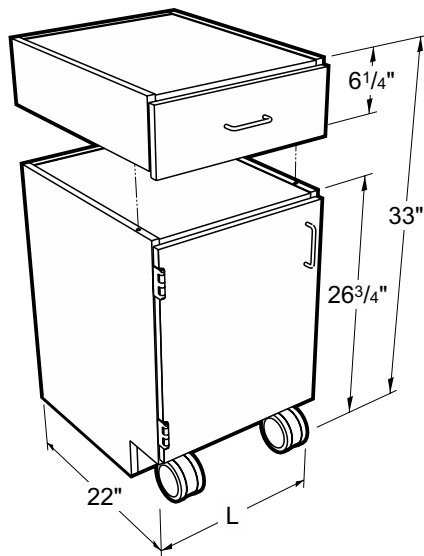

Drawer/Cupboard Cabinets

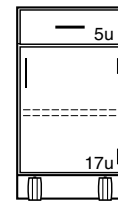

M90W332215L -----	15"L	M90W332215- -----	15"L
M90W332218L -----	18"L	M90W332218- -----	18"L
M90W332221L -----	21"L	M90W332221- -----	21"L
M90W332224L -----	24"L	M90W332224- -----	24"L

Drawer Cabinets

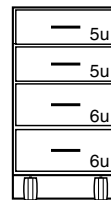

M95W332215- -----	15"L
M95W332218- -----	18"L
M95W332221- -----	21"L
M95W332224- -----	24"L

Mobile Cabinet Tops & Accessories

Specifications:

1" Thick Mobile Cabinet Tops are available in three depths, 22", 23", or 24" and may be used on either Wood or Steel Mobile Cabinets. All edges are finished.

Steel Mobile Cabinet Tops are fabricated from 18 gauge steel and finished to match the cabinet. They are designed for Steel Mobile Cabinets only.

Check height dimension of mobile cabinet with desired top to insure cabinet will fit under bench worksurface frame at required work top height. (see page 75)

1" Thick — Mobile Cabinet Top

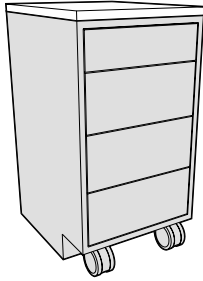

22" Deep flush to front of case

Length	Kemresin®	Kemresin Color Options	Black Phenolic Resin	Black Plastic Laminate
15"	F94R2215-00-__	BK = Black	F94T2215-00	F94P2215-00
18"	F94R2218-00-__	GR = Grey	F94T2218-00	F94P2218-00
21"	F94R2221-00-__	PT = Putty	F94T2221-00	F94P2221-00
24"	F94R2224-00-__	SL = Slate	F94T2224-00	F94P2224-00

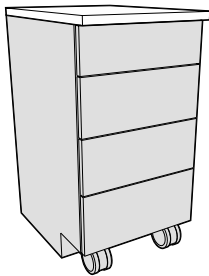

23" Deep flush to overlay door/drawer fronts - 1" overhang of case

Length	Kemresin®	Kemresin Color Options	Black Phenolic Resin	Black Plastic Laminate
15"	F94R2315-00-__	BK = Black	F94T2315-00	F94P2315-00
18"	F94R2318-00-__	GR = Grey	F94T2318-00	F94P2318-00
21"	F94R2321-00-__	PT = Putty	F94T2321-00	F94P2321-00
24"	F94R2324-00-__	SL = Slate	F94T2324-00	F94P2324-00

24" Deep 1" overhang of overlay door/drawer fronts

Length	Kemresin®	Kemresin Color Options	Black Phenolic Resin	Black Plastic Laminate
15"	F94R2415-00-__	BK = Black	F94T2415-00	F94P2415-00
18"	F94R2418-00-__	GR = Grey	F94T2418-00	F94P2418-00
21"	F94R2421-00-__	PT = Putty	F94T2421-00	F94P2421-00
24"	F94R2424-00-__	SL = Slate	F94T2424-00	F94P2424-00

22" Deep — Steel — Mobile Cabinet Top (adds less than 1/4" to height of Mobile Cabinet)

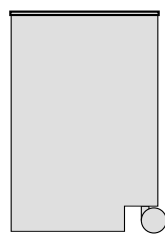
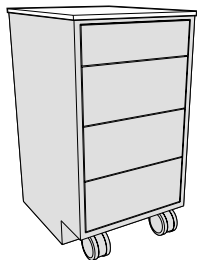

inset cabinet
End View

22" Deep Top for Steel Mobile Cabinets only

Length	Painted Steel
15"	F94M2215-00
18"	F94M2218-00
21"	F94M2221-00
24"	F94M2224-00

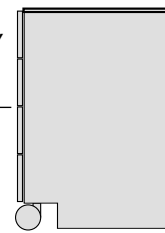

overlay cabinet
End View

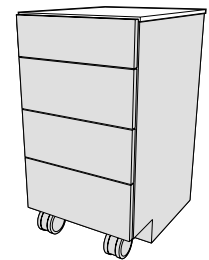

23" Deep — Steel — Mobile Cabinet Top (adds 1/2" to height of Mobile Cabinet)

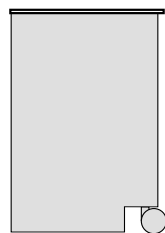
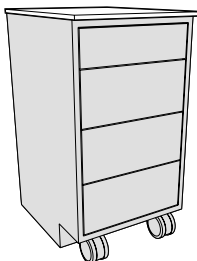

inset cabinet
End View

23" Deep Top for Steel Mobile Cabinets only

Length	Painted Steel
15"	F94M2315-00
18"	F94M2318-00
21"	F94M2321-00
24"	F94M2324-00

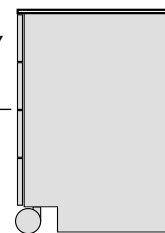

overlay cabinet
End View

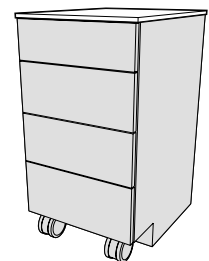

Suspended Base Cabinets – 19" High

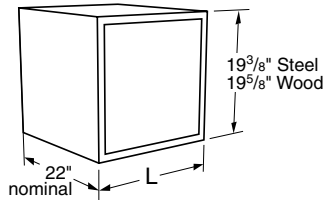

Specifications:

Suspended Base Cabinets are designed to hang beneath 30" or 36" deep worksurface frames. They are available in either steel or wood construction.

Cabinets on this page are a nominal 19" high, and are available in lengths shown.

See page 38 for designating cabinet style, door and drawer head material, and hardware selection.

Cupboard Base Cabinets

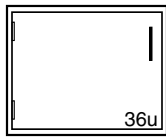

Steel Cabinet	Length	Wood Cabinet
C03C192215L	15"	C03W202215L
C03C192218L	18"	C03W202218L
C03C192221L	21"	C03W202221L
C03C192224L	24"	C03W202224L

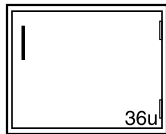
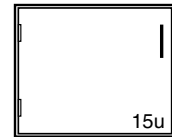

Steel Cabinet	Length	Wood Cabinet
C03C192215-	15"	C03W202215-
C03C192218-	18"	C03W202218-
C03C192221-	21"	C03W202221-
C03C192224-	24"	C03W202224-



Drawer Base Cabinets

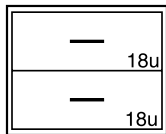

Steel Cabinet	Length	Wood Cabinet
D00C192215-	30"	D00W202215- 0
D00C192218-	36"	D00W202218- 0
D00C192221-	42"	D00W202221- 0
D00C192224-	48"	D00W202224- 0

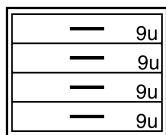

Steel Cabinet	Length	Wood Cabinet
D30C192215-	15"	D30W202215- 0
D30C192218-	18"	D30W202218- 0
D30C192221-	21"	D30W202221- 0
D30C192224-	24"	D30W202224- 0

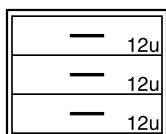
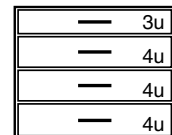

Steel Cabinet	Length	Wood Cabinet
D50C192215-	15"	D50W202215- 0
D50C192218-	18"	D50W202218- 0
D50C192221-	21"	D50W202221- 0
D50C192224-	24"	D50W202224- 0

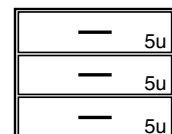

Suspended Base Cabinets – 19" High

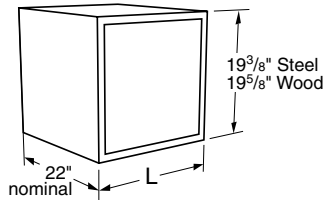

Specifications:

Suspended Base Cabinets are designed to hang beneath 30" or 36" deep worksurface frames. They are available in either steel or wood construction.

Cabinets on this page are a nominal 19" high, and are available in lengths shown.

See page 38 for designating cabinet style, door and drawer head material, and hardware selection.

Drawer Base Cabinets

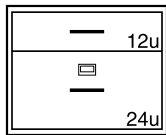

1 File Drawer with hangers

Steel Cabinet	Length	Wood Cabinet
D81C192215- -----	15"	D81W202215- 0
D81C192218- -----	18"	D81W202218- 0
D81C192221- -----	21"	D81W202221- 0
D81C192224- -----	24"	D81W202224- 0

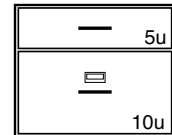

1 File Drawer with hangers

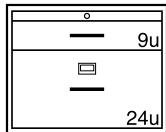

Steel Cabinet	Length	Wood Cabinet
D85C192215- -----	15"	D85W202215- 0
D85C192218- -----	18"	D85W202218- 0
D85C192221- -----	21"	D85W202221- 0
D85C192224- -----	24"	D85W202224- 0

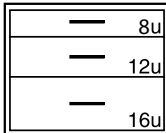
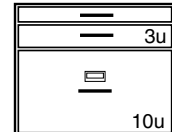

Steel Cabinet	Length	Wood Cabinet
D86C192215- -----	15"	D86W202215- 0
D86C192218- -----	18"	D86W202218- 0
D86C192221- -----	21"	D86W202221- 0
D86C192224- -----	24"	D86W202224- 0

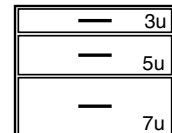

Suspended Base Cabinets – 25" High

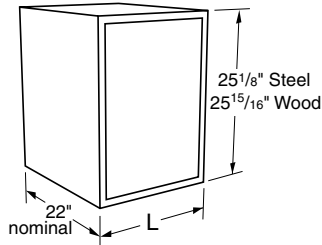

Specifications:

Suspended Base Cabinets are designed to hang beneath 30" or 36" deep worksurface frames. They are available in either steel or wood construction.

Cabinets on this page are a nominal 25" high, and are available in lengths shown.

See page 38 for designating cabinet style, door and drawer head material, and hardware selection.

Cupboard Base Cabinets

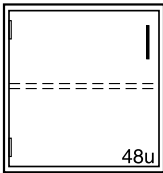

Steel Cabinet	Length	Wood Cabinet
C03C252215L -----	15"	C03W262215L_0 ---
C03C252218L -----	18"	C03W262218L_0 ---
C03C252221L -----	21"	C03W262221L_0 ---
C03C252224L -----	24"	C03W262224L_0 ---

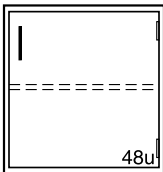
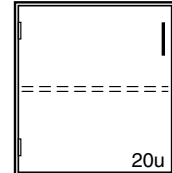

Steel Cabinet	Length	Wood Cabinet
C03C252215- -----	15"	C03W262215-_0 ---
C03C252218- -----	18"	C03W262218-_0 ---
C03C252221- -----	21"	C03W262221-_0 ---
C03C252224- -----	24"	C03W262224-_0 ---

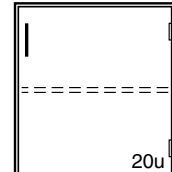

Drawer Base Cabinets

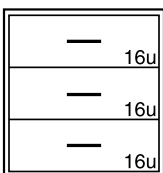

Steel Cabinet	Length	Wood Cabinet
D00C252215- -----	15"	D00W262215-_0 ---
D00C252218- -----	18"	D00W262218-_0 ---
D00C252221- -----	21"	D00W262221-_0 ---
D00C252224- -----	24"	D00W262224-_0 ---

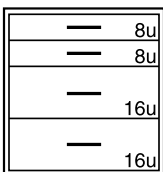
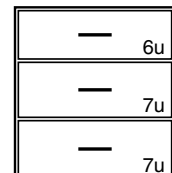

Steel Cabinet	Length	Wood Cabinet
D08C252215- -----	15"	D08W262215-_0 ---
D08C252218- -----	18"	D08W262218-_0 ---
D08C252221- -----	21"	D08W262221-_0 ---
D08C252224- -----	24"	D08W262224-_0 ---

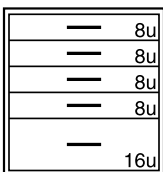
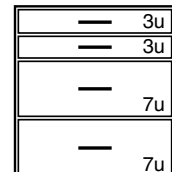

Steel Cabinet	Length	Wood Cabinet
D10C252215- -----	15"	D10W262215-_0 ---
D10C252218- -----	18"	D10W262218-_0 ---
D10C252221- -----	21"	D10W262221-_0 ---
D10C252224- -----	24"	D10W262224-_0 ---

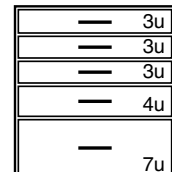

Suspended Base Cabinets – 25" High

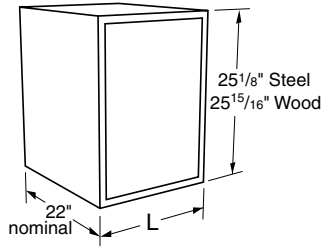

Specifications:

Suspended Base Cabinets are designed to hang beneath 30" or 36" deep worksurface frames. They are available in either steel or wood construction.

Cabinets on this page are a nominal 25" high, and are available in lengths shown.

See page 38 for designating cabinet style, door and drawer head material, and hardware selection.

Drawer Base Cabinets

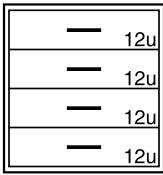

Steel Cabinet	Length	Wood Cabinet
D30C252215- -----	15"	D30W262215- 0
D30C252218- -----	18"	D30W262218- 0
D30C252221- -----	21"	D30W262221- 0
D30C252224- -----	24"	D30W262224- 0

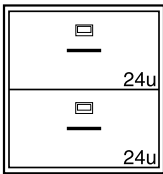
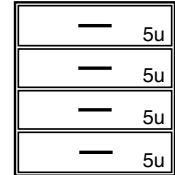

Steel Cabinet	Length	Wood Cabinet
D81C252215- -----	15"	D81W262215- 0
D81C252218- -----	18"	D81W262218- 0
D81C252221- -----	21"	D81W262221- 0
D81C252224- -----	24"	D81W262224- 0

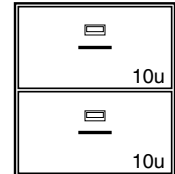

2 File Drawers with hangers

2 File Drawers with hangers

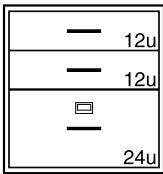

Steel Cabinet	Length	Wood Cabinet
D85C252215- -----	15"	D85W262215- 0
D85C252218- -----	18"	D85W262218- 0
D85C252221- -----	21"	D85W262221- 0
D85C252224- -----	24"	D85W262224- 0

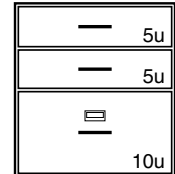

1 File Drawer with hangers

1 File Drawer with hangers

Suspended Base Cabinets – 25" High

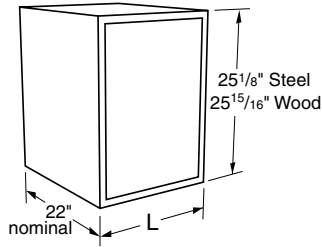

Specifications:

Suspended Base Cabinets are designed to hang beneath 30" or 36" deep worksurface frames. They are available in either steel or wood construction.

Cabinets on this page are a nominal 25" high, and are available in lengths shown.

See page 38 for designating cabinet style, door and drawer head material, and hardware selection.

Drawer & Cupboard Base Cabinets

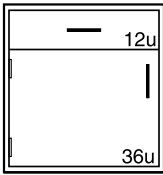

Steel Cabinet	Length	Wood Cabinet
E40C252215L	15"	E40W262215L
E40C252218L	18"	E40W262218L
E40C252221L	21"	E40W262221L
E40C252224L	24"	E40W262224L

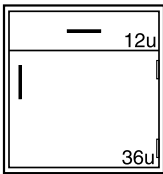
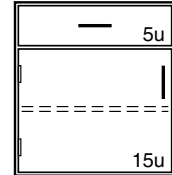

Steel Cabinet	Length	Wood Cabinet
E40C252215-	15"	E40W262215-
E40C252218-	18"	E40W262218-
E40C252221-	21"	E40W262221-
E40C252224-	24"	E40W262224-

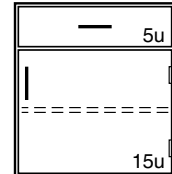

Steel Suspended Drawer Units

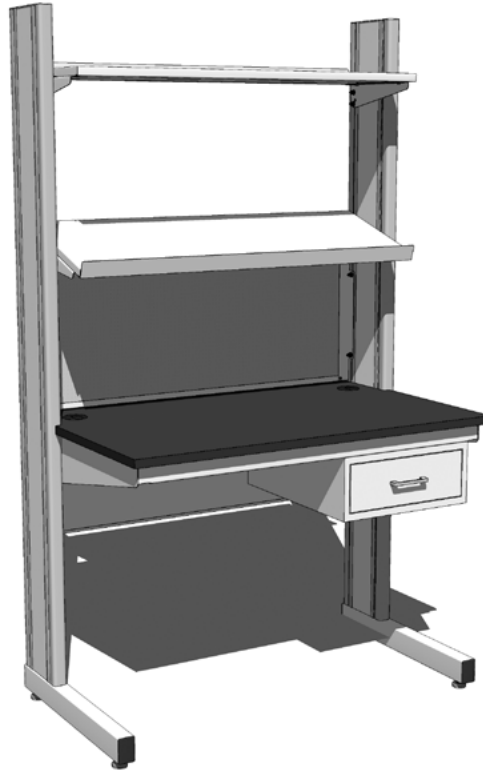

Steel Suspended Drawer Units are designed to hang beneath 30" or 36" deep module frames. They are available in steel construction only and are furnished complete with all required mounting hardware.

Steel Suspended Drawer Units may be stacked to create multiple drawer unit assemblies.

Note: Last four digits of part number designates drawer head style and pull selection. See page 38 for full explanation. Actual product may vary slightly from catalog illustration due to style and hardware selection.

Steel Suspended Drawer Units

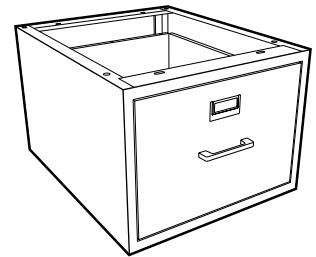
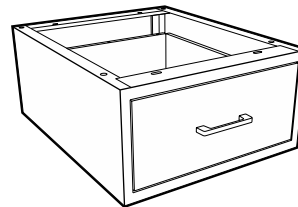
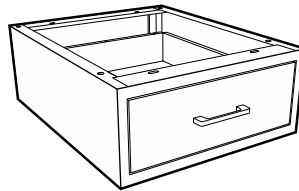
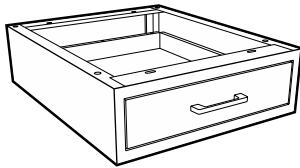

5 1/2" High Drawer Unit	L
D00C062215-	15"
D00C062218-	18"
D00C062221-	21"
D00C062224-	24"

Overall Dimensions	
Overall Height	5 1/2"
Overall Depth	22"
Drawer Head Height	3 3/4"
Inside Dimensions	
Height/Clearance	2 3/8"
Front-to-back	18"

7 1/2" High Drawer Unit	L
D00C082215-	15"
D00C082218-	18"
D00C082221-	21"
D00C082224-	24"

Overall Dimensions	
Overall Height	7 1/2"
Overall Depth	22"
Drawer Head Height	5 1/16"
Inside Dimensions	
Height/Clearance	4 7/16"
Front-to-back	18"

9" High Drawer Unit	L
D00C092215-	15"
D00C092218-	18"
D00C092221-	21"
D00C092224-	24"

Overall Dimensions	
Overall Height	9"
Overall Depth	22"
Drawer Head Height	7 1/8"
Inside Dimensions	
Height/Clearance	5 7/8"
Front-to-back	18"

File Drawer Unit	L
D00C132215-	15"
D00C132218-	18"
D00C132221-	21"
D00C132224-	24"

Overall Dimensions	
Overall Height	13 1/4"
Overall Depth	22"
Drawer Head Height	11 1/2"
Inside Dimensions	
Height/Clearance	10 1/4"
Front-to-back	18"

Upper Storage Cabinets

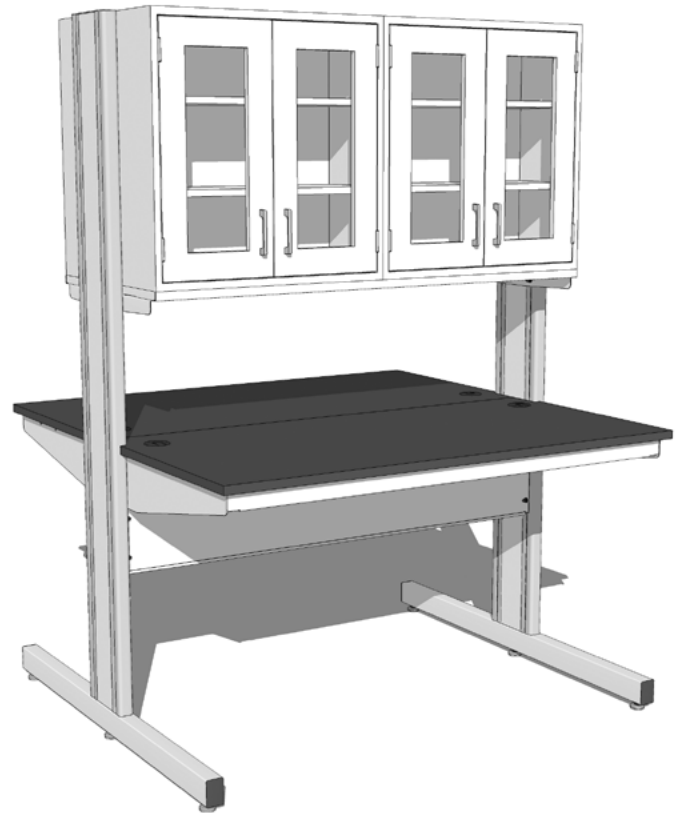
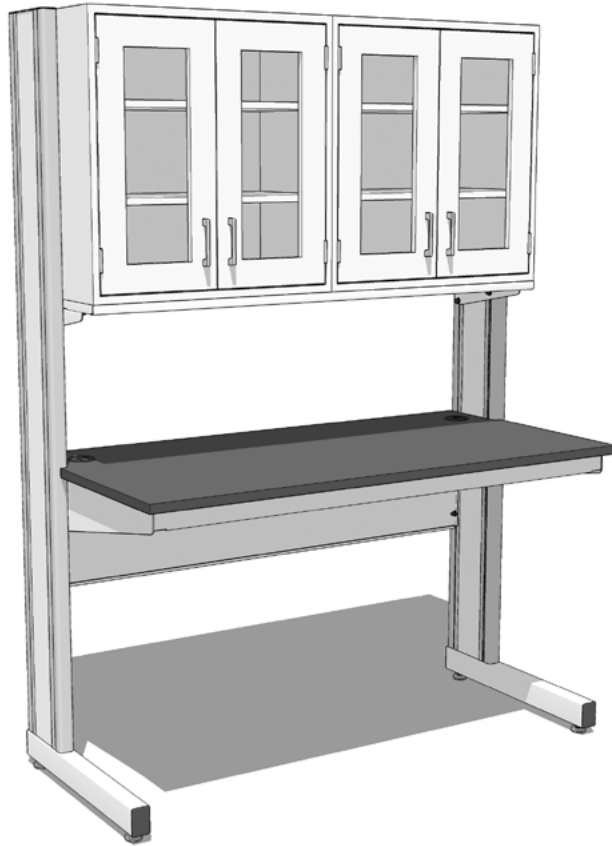

Sliding Plate Glass Door Cabinets

Single-sided Steel Cabinets

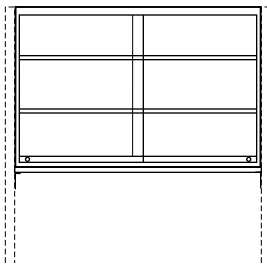

Depth Steel Cabinet	Length
12 ³ / ₄ " FW10C301330-00_0-	30"
12 ³ / ₄ " FW10C301336-00_0-	36"
12 ³ / ₄ " FW10C301342-00_0-	42"
12 ³ / ₄ " FW10C301348-00_0-	48"
16" FW10C301630-00_0-	30"
16" FW10C301636-00_0-	36"
16" FW10C301642-00_0-	42"
16" FW10C301648-00_0-	48"

Double-sided Steel Cabinets

Depth Steel Cabinet	Length
25 ¹ / ₂ " FW10C302630-00_0-	30"
25 ¹ / ₂ " FW10C302636-00_0-	36"
25 ¹ / ₂ " FW10C302642-00_0-	42"
25 ¹ / ₂ " FW10C302648-00_0-	48"
32" FW10C303230-00_0-	30"
32" FW10C303236-00_0-	36"
32" FW10C303242-00_0-	42"
32" FW10C303248-00_0-	42"

Upper Storage Cabinets

Upper Storage Cabinets are used in place of open shelving when enclosed storage and/or resistance to dust is required. Cabinets are available in powder coated steel or hardwood veneer plywood construction, and in a variety of door styles. All Evolution upper cabinets are 30" high and include two adjustable shelves. Double-sided cabinets use two single-sided cabinets mounted back-to-back on a single support assembly. Cabinets

mount between columns and include support assembly and mounting hardware. Add **-09** or **-12** to end of part number to indicate column depth of supporting module.

Note: Last four digits of part number designates cabinet/door style and hardware selection. See page 38 for full explanation. Actual product may vary slightly from catalog illustration due to style and hardware selection.

Sliding Glazed Door Cabinets

Single-sided Steel Cabinets Single-sided Wood Cabinets

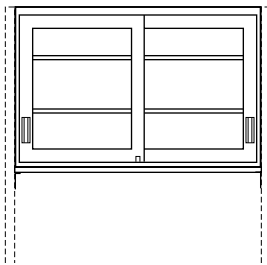

Depth Steel Cabinet	Length Wood Cabinet	Depth
12 ³ / ₄ " FW41C301330-0_0_	30" FW11W301230-00_0_	12"
12 ³ / ₄ " FW41C301336-0_0_	36" FW11W301236-00_0_	12"
12 ³ / ₄ " FW41C301342-0_0_	42" FW11W301242-00_0_	12"
12 ³ / ₄ " FW41C301348-0_0_	48" FW11W301248-00_0_	12"
16" FW41C301630-0_0_	30" FW11W301630-00_0_	16"
16" FW41C301636-0_0_	36" FW11W301636-00_0_	16"
16" FW41C301642-0_0_	42" FW11W301642-00_0_	16"
16" FW41C301648-0_0_	48" FW11W301648-00_0_	16"

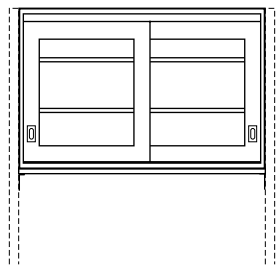

Double-sided Steel Cabinets Double-sided Wood Cabinets

Depth Steel Cabinet	Length Wood Cabinet	Depth
25 ¹ / ₂ " FW41C302630-0_0_	30" FW11W302430-00_0_	24"
25 ¹ / ₂ " FW41C302636-0_0_	36" FW11W302436-00_0_	24"
25 ¹ / ₂ " FW41C302642-0_0_	42" FW11W302442-00_0_	24"
25 ¹ / ₂ " FW41C302648-0_0_	48" FW11W302448-00_0_	24"
32" FW41C303230-0_0_	30" FW11W303230-00_0_	32"
32" FW41C303236-0_0_	36" FW11W303236-00_0_	32"
32" FW41C303242-0_0_	42" FW11W303242-00_0_	32"
32" FW41C303248-0_0_	48" FW11W303248-00_0_	32"

Sliding Panel Door Cabinets

Single-sided Steel Cabinets Single-sided Wood Cabinets

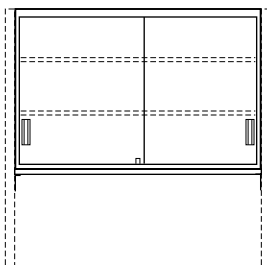

Depth Steel Cabinet	Length Wood Cabinet	Depth
12 ³ / ₄ " FW12C301330-0_0_	30" FW12W301230-00_0_	12"
12 ³ / ₄ " FW12C301336-0_0_	36" FW12W301236-00_0_	12"
12 ³ / ₄ " FW12C301342-0_0_	42" FW12W301242-00_0_	12"
12 ³ / ₄ " FW12C301348-0_0_	48" FW12W301248-00_0_	12"
16" FW12C301630-0_0_	30" FW12W301630-00_0_	16"
16" FW12C301636-0_0_	36" FW12W301636-00_0_	16"
16" FW12C301642-0_0_	42" FW12W301642-00_0_	16"
16" FW12C301648-0_0_	48" FW12W301648-00_0_	16"

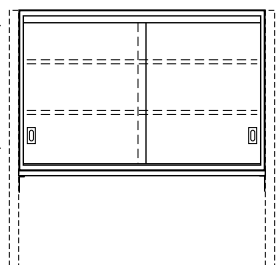

Double-sided Steel Cabinets Double-sided Wood Cabinets

Depth Steel Cabinet	Length Wood Cabinet	Depth
25 ¹ / ₂ " FW12C302630-0_0_	30" FW12W302430-00_0_	24"
25 ¹ / ₂ " FW12C302636-0_0_	36" FW12W302436-00_0_	24"
25 ¹ / ₂ " FW12C302642-0_0_	42" FW12W302442-00_0_	24"
25 ¹ / ₂ " FW12C302648-0_0_	48" FW12W302448-00_0_	24"
32" FW12C303230-0_0_	30" FW12W303230-00_0_	32"
32" FW12C303236-0_0_	36" FW12W303236-00_0_	32"
32" FW12C303242-0_0_	42" FW12W303242-00_0_	32"
32" FW12C303248-0_0_	48" FW12W303248-00_0_	32"

Upper Storage Cabinets

Upper Storage Cabinets are used in place of open shelving when enclosed storage and/or resistance to dust is required. Cabinets are available in powder coated steel or hardwood veneer plywood construction, and in a variety of door styles. All Evolution upper cabinets are 30" high and include two adjustable shelves. Double-sided cabinets use two single-sided cabinets mounted back-to-back on a single support assembly. Cabinets mount

between columns and include support assembly and mounting hardware. Add **-09** or **-12** to end of part number to indicate column depth of supporting module.

Note: Last four digits of part number designates cabinet/door style and hardware selection. See page 38 for full explanation. Actual product may vary slightly from catalog illustration due to style and hardware selection.

Swinging Glazed Door Cabinets

Single-sided Steel Cabinets Single-sided Wood Cabinets

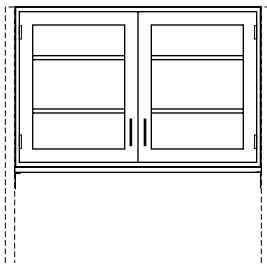

Depth Steel Cabinet	Length Wood Cabinet	Depth
12 ³ / ₄ " FW50C301330-	30" FW20W301230-	12"
12 ³ / ₄ " FW50C301336-	36" FW20W301236-	12"
12 ³ / ₄ " FW50C301342-	42" FW20W301242-	12"
12 ³ / ₄ " FW50C301348-	48" FW20W301248-	12"
16" FW50C301630-	30" FW20W301630-	16"
16" FW50C301636-	36" FW20W301636-	16"
16" FW50C301642-	42" FW20W301642-	16"
16" FW50C301648-	48" FW20W301648-	16"

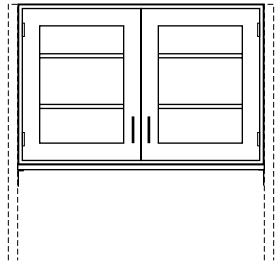

Double-sided Steel Cabinets Double-sided Wood Cabinets

Depth Steel Cabinet	Length Wood Cabinet	Depth
25 ¹ / ₂ " FW50C302630-	30" FW20W302430-	24"
25 ¹ / ₂ " FW50C302636-	36" FW20W302436-	24"
25 ¹ / ₂ " FW50C302642-	42" FW20W302442-	24"
25 ¹ / ₂ " FW50C302648-	48" FW20W302448-	24"
32" FW50C303230-	30" FW20W303230-	32"
32" FW50C303236-	36" FW20W303236-	32"
32" FW50C303242-	42" FW20W303242-	32"
32" FW50C303248-	48" FW20W303248-	32"

Swinging Panel Door Cabinets

Single-sided Steel Cabinets Single-sided Wood Cabinets

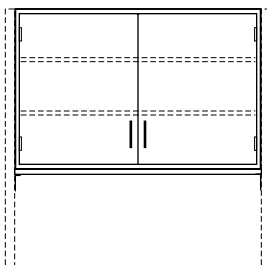

Depth Steel Cabinet	Length Wood Cabinet	Depth
12 ³ / ₄ " FW25C301330-	30" FW25W301230-	12"
12 ³ / ₄ " FW25C301336-	36" FW25W301236-	12"
12 ³ / ₄ " FW25C301342-	42" FW25W301242-	12"
12 ³ / ₄ " FW25C301348-	48" FW25W301248-	12"
16" FW25C301630-	30" FW25W301630-	16"
16" FW25C301636-	36" FW25W301636-	16"
16" FW25C301642-	42" FW25W301642-	16"
16" FW25C301648-	48" FW25W301648-	16"

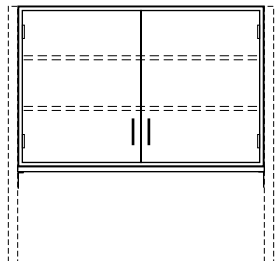

Double-sided Steel Cabinets Double-sided Wood Cabinets

Depth Steel Cabinet	Length Wood Cabinet	Depth
25 ¹ / ₂ " FW25C302630-	30" FW25W302430-	24"
25 ¹ / ₂ " FW25C302636-	36" FW25W302436-	24"
25 ¹ / ₂ " FW25C302642-	42" FW25W302442-	24"
25 ¹ / ₂ " FW25C302648-	48" FW25W302448-	24"
32" FW25C303230-	30" FW25W303230-	32"
32" FW25C303236-	36" FW25W303236-	32"
32" FW25C303242-	42" FW25W303242-	32"
32" FW25C303248-	48" FW25W303248-	32"

Pass-thru Upper Storage Cabinets

Sliding Plate Glass Door Cabinets

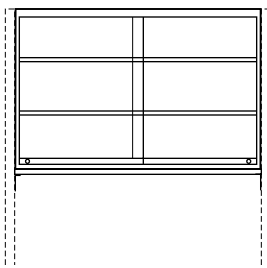

Depth	Steel Cabinet	Length	Wood Cabinet	Depth
16"	FW13C301630-00_0-	30"	FW13W301630-00_0-	16"
16"	FW13C301636-00_0-	36"	FW13W301636-00_0-	16"
16"	FW13C301642-00_0-	42"	FW13W301642-00_0-	16"
16"	FW13C301648-00_0-	48"	FW13W301648-00_0-	16"
22"	FW13C302230-00_0-	30"	FW13W302230-00_0-	22"
22"	FW13C302236-00_0-	36"	FW13W302236-00_0-	22"
22"	FW13C302242-00_0-	42"	FW13W302242-00_0-	22"
22"	FW13C302248-00_0-	48"	FW13W302248-00_0-	22"

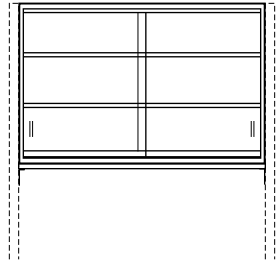

Sliding Glazed Glass Door Cabinets

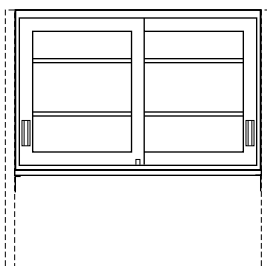

Depth	Steel Cabinet	Length	Wood Cabinet	Depth
16"	FW44C301630-0_0-	30"	FW14W301630-00_0-	16"
16"	FW44C301636-0_0-	36"	FW14W301636-00_0-	16"
16"	FW44C301642-0_0-	42"	FW14W301642-00_0-	16"
16"	FW44C301648-0_0-	48"	FW14W301648-00_0-	16"
22"	FW44C302230-0_0-	30"	FW14W302230-00_0-	22"
22"	FW44C302236-0_0-	36"	FW14W302236-00_0-	22"
22"	FW44C302242-0_0-	42"	FW14W302242-00_0-	22"
22"	FW44C302248-0_0-	48"	FW14W302248-00_0-	22"

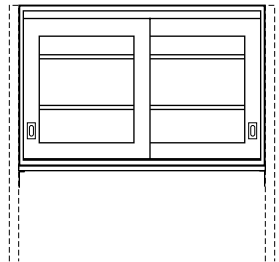

Sliding Panel Door Cabinets

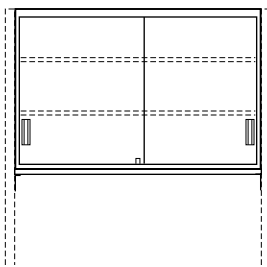

Depth	Steel Cabinet	Length	Wood Cabinet	Depth
16"	FW15C301630-0_0-	30"	FW15W301630-00_0-	16"
16"	FW15C301636-0_0-	36"	FW15W301636-00_0-	16"
16"	FW15C301642-0_0-	42"	FW15W301642-00_0-	16"
16"	FW15C301648-0_0-	48"	FW15W301648-00_0-	16"
22"	FW15C302230-0_0-	30"	FW15W302230-00_0-	22"
22"	FW15C302236-0_0-	36"	FW15W302236-00_0-	22"
22"	FW15C302242-0_0-	42"	FW15W302242-00_0-	22"
22"	FW15C302248-0_0-	48"	FW15W302248-00_0-	22"

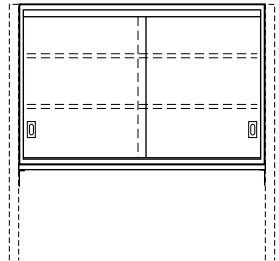

Swinging Glazed Door Cabinets

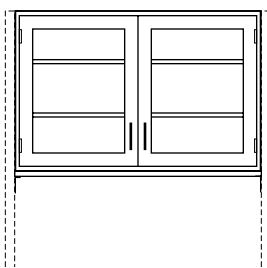

Depth	Steel Cabinet	Length	Wood Cabinet	Depth
16"	FW53C301630- - -	30"	FW23W301630- - -	16"
16"	FW53C301636- - -	36"	FW23W301636- - -	16"
16"	FW53C301642- - -	42"	FW23W301642- - -	16"
16"	FW53C301648- - -	48"	FW23W301648- - -	16"
22"	FW53C302230- - -	30"	FW23W302230- - -	22"
22"	FW53C302236- - -	36"	FW23W302236- - -	22"
22"	FW53C302242- - -	42"	FW23W302242- - -	22"
22"	FW53C302248- - -	48"	FW23W302248- - -	22"

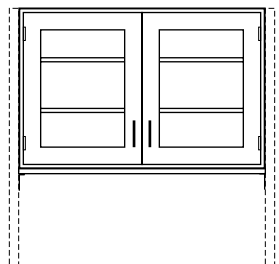

Swinging Panel Door Cabinets

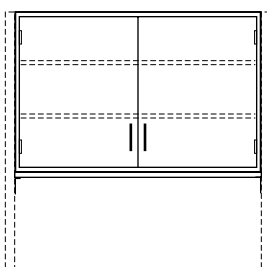

Depth	Steel Cabinet	Length	Wood Cabinet	Depth
16"	FW28C301630- - -	30"	FW28W301630- - -	16"
16"	FW28C301636- - -	36"	FW28W301636- - -	16"
16"	FW28C301642- - -	42"	FW28W301642- - -	16"
16"	FW28C301648- - -	48"	FW28W301648- - -	16"
22"	FW28C302230- - -	30"	FW28W302230- - -	22"
22"	FW28C302236- - -	36"	FW28W302236- - -	22"
22"	FW28C302242- - -	42"	FW28W302242- - -	22"
22"	FW28C302248- - -	48"	FW28W302248- - -	22"

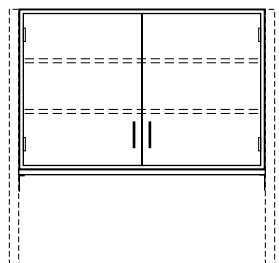

Upper Storage Cabinets

Upper Storage Cabinets are used in place of open shelving when enclosed storage and/or resistance to dust is required. Cabinets are available in powder coated steel or hardwood veneer plywood construction, and in a variety of door styles. All Evolution upper cabinets are 30" high and include two adjustable shelves. Double-sided cabinets use two single-sided cabinets mounted back-to-back on a single support assembly. Cabinets mount

between columns and include support assembly and mounting hardware. Add **-09** or **-12** to end of part number to indicate column depth of supporting module.

Note: Last four digits of part number designates cabinet/door style and hardware selection. See page 38 for full explanation. Actual product may vary slightly from catalog illustration due to style and hardware selection.

Sliding Plate Glass Door Cabinets

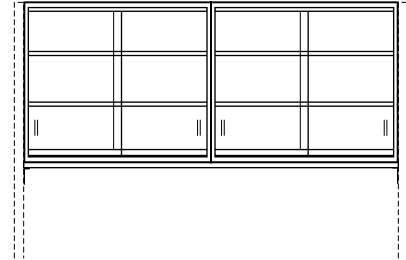
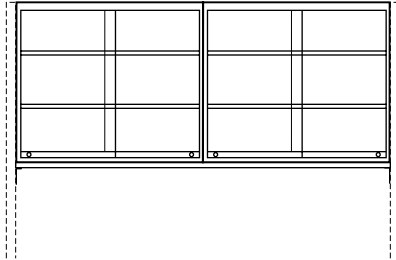

Single-sided Steel Cabinets

Depth	Steel Cabinet	Length
12 ³ / ₄ "	FW10C301354-00_0_	54"
12 ³ / ₄ "	FW10C301360-00_0_	60"
12 ³ / ₄ "	FW10C301366-00_0_	66"
12 ³ / ₄ "	FW10C301372-00_0_	72"
12 ³ / ₄ "	FW10C301378-00_0_	78"
12 ³ / ₄ "	FW10C301384-00_0_	84"
12 ³ / ₄ "	FW10C301390-00_0_	90"
12 ³ / ₄ "	FW10C301396-00_0_	96"
16"	FW10C301654-00_0_	54"
16"	FW10C301660-00_0_	60"
16"	FW10C301666-00_0_	66"
16"	FW10C301672-00_0_	72"
16"	FW10C301678-00_0_	78"
16"	FW10C301684-00_0_	84"
16"	FW10C301690-00_0_	90"
16"	FW10C301696-00_0_	96"

Single-sided Wood Cabinets

Depth	Wood Cabinet	Length
12"	FW10W301254-00_0_	54"
12"	FW10W301260-00_0_	60"
12"	FW10W301266-00_0_	66"
12"	FW10W301272-00_0_	72"
12"	FW10W301278-00_0_	78"
12"	FW10W301284-00_0_	84"
12"	FW10W301290-00_0_	90"
12"	FW10W301296-00_0_	96"
16"	FW10W301654-00_0_	54"
16"	FW10W301660-00_0_	60"
16"	FW10W301666-00_0_	66"
16"	FW10W301672-00_0_	72"
16"	FW10W301678-00_0_	78"
16"	FW10W301684-00_0_	84"
16"	FW10W301690-00_0_	90"
16"	FW10W301696-00_0_	96"

Double-sided Steel Cabinets

Depth	Steel Cabinet	Length
25 ¹ / ₂ "	FW10C302654-00_0_	54"
25 ¹ / ₂ "	FW10C302660-00_0_	60"
25 ¹ / ₂ "	FW10C302666-00_0_	66"
25 ¹ / ₂ "	FW10C302672-00_0_	72"
25 ¹ / ₂ "	FW10C302678-00_0_	78"
25 ¹ / ₂ "	FW10C302684-00_0_	84"
25 ¹ / ₂ "	FW10C302690-00_0_	90"
25 ¹ / ₂ "	FW10C302696-00_0_	96"
32"	FW10C303254-00_0_	54"
32"	FW10C303260-00_0_	60"
32"	FW10C303266-00_0_	66"
32"	FW10C303272-00_0_	72"
32"	FW10C303278-00_0_	78"
32"	FW10C303284-00_0_	84"
32"	FW10C303290-00_0_	90"
32"	FW10C303296-00_0_	96"

Double-sided Wood Cabinets

Depth	Wood Cabinet	Length
24"	FW10W302454-00_0_	54"
24"	FW10W302460-00_0_	60"
24"	FW10W302466-00_0_	66"
24"	FW10W302472-00_0_	72"
24"	FW10W302478-00_0_	78"
24"	FW10W302484-00_0_	84"
24"	FW10W302490-00_0_	90"
24"	FW10W302496-00_0_	96"
32"	FW10W303254-00_0_	54"
32"	FW10W303260-00_0_	60"
32"	FW10W303266-00_0_	66"
32"	FW10W303272-00_0_	72"
32"	FW10W303278-00_0_	78"
32"	FW10W303284-00_0_	84"
32"	FW10W303290-00_0_	90"
32"	FW10W303296-00_0_	96"

Upper Storage Cabinets

Upper Storage Cabinets are used in place of open shelving when enclosed storage and/or resistance to dust is required. Cabinets are available in powder coated steel or hardwood veneer plywood construction, and in a variety of door styles. All Evolution upper cabinets are 30" high and include two adjustable shelves. Double-sided cabinets use two single-sided cabinets mounted back-to-back on a single support assembly. Cabinets mount

between columns and include support assembly and mounting hardware. Add **-09** or **-12** to end of part number to indicate column depth of supporting module.

Note: Last four digits of part number designates cabinet/door style and hardware selection. See page 38 for full explanation. Actual product may vary slightly from catalog illustration due to style and hardware selection.

Sliding Glazed Door Cabinets

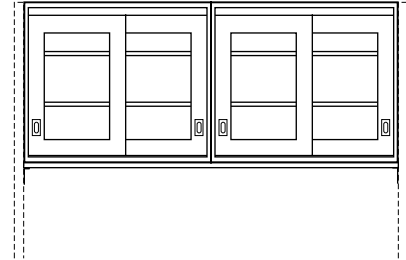
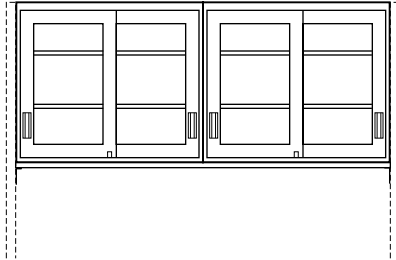

Single-sided Steel Cabinets

Depth	Steel Cabinet	Length
12 ³ / ₄ "	FW41C301354-0_0_	54"
12 ³ / ₄ "	FW41C301360-0_0_	60"
12 ³ / ₄ "	FW41C301366-0_0_	66"
12 ³ / ₄ "	FW41C301372-0_0_	72"
12 ³ / ₄ "	FW41C301378-0_0_	78"
12 ³ / ₄ "	FW41C301384-0_0_	84"
12 ³ / ₄ "	FW41C301390-0_0_	90"
12 ³ / ₄ "	FW41C301396-0_0_	96"
16"	FW41C301654-0_0_	54"
16"	FW41C301660-0_0_	60"
16"	FW41C301666-0_0_	66"
16"	FW41C301672-0_0_	72"
16"	FW41C301678-0_0_	78"
16"	FW41C301684-0_0_	84"
16"	FW41C301690-0_0_	90"
16"	FW41C301696-0_0_	96"

Single-sided Wood Cabinets

Depth	Wood Cabinet	Length
12"	FW11W301254-00_0_	54"
12"	FW11W301260-00_0_	60"
12"	FW11W301266-00_0_	66"
12"	FW11W301272-00_0_	72"
12"	FW11W301278-00_0_	78"
12"	FW11W301284-00_0_	84"
12"	FW11W301290-00_0_	90"
12"	FW11W301296-00_0_	96"
16"	FW11W301654-00_0_	54"
16"	FW11W301660-00_0_	60"
16"	FW11W301666-00_0_	66"
16"	FW11W301672-00_0_	72"
16"	FW11W301678-00_0_	78"
16"	FW11W301684-00_0_	84"
16"	FW11W301690-00_0_	90"
16"	FW11W301696-00_0_	96"

Double-sided Steel Cabinets

Depth	Steel Cabinet	Length
25 ¹ / ₂ "	FW41C302654-0_0_	54"
25 ¹ / ₂ "	FW41C302660-0_0_	60"
25 ¹ / ₂ "	FW41C302666-0_0_	66"
25 ¹ / ₂ "	FW41C302672-0_0_	72"
25 ¹ / ₂ "	FW41C302678-0_0_	78"
25 ¹ / ₂ "	FW41C302684-0_0_	84"
25 ¹ / ₂ "	FW41C302690-0_0_	90"
25 ¹ / ₂ "	FW41C302696-0_0_	96"
32"	FW41C303254-0_0_	54"
32"	FW41C303260-0_0_	60"
32"	FW41C303266-0_0_	66"
32"	FW41C303272-0_0_	72"
32"	FW41C303278-0_0_	78"
32"	FW41C303284-0_0_	84"
32"	FW41C303290-0_0_	90"
32"	FW41C303296-0_0_	96"

Double-sided Wood Cabinets

Depth	Wood Cabinet	Length
24"	FW11W302454-00_0_	54"
24"	FW11W302460-00_0_	60"
24"	FW11W302466-00_0_	66"
24"	FW11W302472-00_0_	72"
24"	FW11W302478-00_0_	78"
24"	FW11W302484-00_0_	84"
24"	FW11W302490-00_0_	90"
24"	FW11W302496-00_0_	96"
32"	FW11W303254-00_0_	54"
32"	FW11W303260-00_0_	60"
32"	FW11W303266-00_0_	66"
32"	FW11W303272-00_0_	72"
32"	FW11W303278-00_0_	78"
32"	FW11W303284-00_0_	84"
32"	FW11W303290-00_0_	90"
32"	FW11W303296-00_0_	96"

Upper Storage Cabinets

Upper Storage Cabinets are used in place of open shelving when enclosed storage and/or resistance to dust is required. Cabinets are available in powder coated steel or hardwood veneer plywood construction, and in a variety of door styles. All Evolution upper cabinets are 30" high and include two adjustable shelves. Double-sided cabinets use two single-sided cabinets mounted back-to-back on a single support assembly. Cabinets mount

between columns and include support assembly and mounting hardware. Add **-09** or **-12** to end of part number to indicate column depth of supporting module.

Note: Last four digits of part number designates cabinet/door style and hardware selection. See page 38 for full explanation. Actual product may vary slightly from catalog illustration due to style and hardware selection.

Sliding Panel Door Cabinets

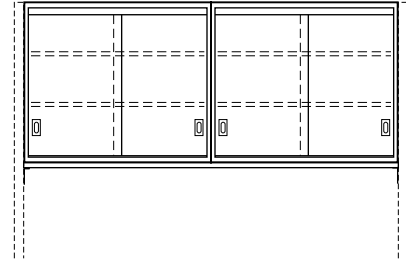
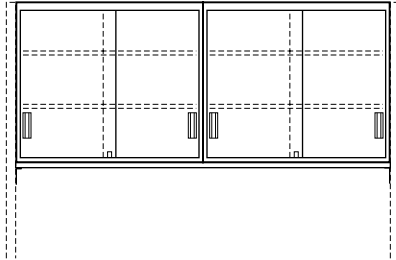

Single-sided Steel Cabinets

Depth	Steel Cabinet	Length
12 ³ / ₄ "	FW12C301354-0_0_	54"
12 ³ / ₄ "	FW12C301360-0_0_	60"
12 ³ / ₄ "	FW12C301366-0_0_	66"
12 ³ / ₄ "	FW12C301372-0_0_	72"
12 ³ / ₄ "	FW12C301378-0_0_	78"
12 ³ / ₄ "	FW12C301384-0_0_	84"
12 ³ / ₄ "	FW12C301390-0_0_	90"
12 ³ / ₄ "	FW12C301396-0_0_	96"
16"	FW12C301654-0_0_	54"
16"	FW12C301660-0_0_	60"
16"	FW12C301666-0_0_	66"
16"	FW12C301672-0_0_	72"
16"	FW12C301678-0_0_	78"
16"	FW12C301684-0_0_	84"
16"	FW12C301690-0_0_	90"
16"	FW12C301696-0_0_	96"

Single-sided Wood Cabinets

Depth	Wood Cabinet	Length
12"	FW12W301254-00_0_	54"
12"	FW12W301260-00_0_	60"
12"	FW12W301266-00_0_	66"
12"	FW12W301272-00_0_	72"
12"	FW12W301278-00_0_	78"
12"	FW12W301284-00_0_	84"
12"	FW12W301290-00_0_	90"
12"	FW12W301296-00_0_	96"
16"	FW12W301654-00_0_	54"
16"	FW12W301660-00_0_	60"
16"	FW12W301666-00_0_	66"
16"	FW12W301672-00_0_	72"
16"	FW12W301678-00_0_	78"
16"	FW12W301684-00_0_	84"
16"	FW12W301690-00_0_	90"
16"	FW12W301696-00_0_	96"

Double-sided Steel Cabinets

Depth	Steel Cabinet	Length
25 ¹ / ₂ "	FW12C302654-0_0_	54"
25 ¹ / ₂ "	FW12C302660-0_0_	60"
25 ¹ / ₂ "	FW12C302666-0_0_	66"
25 ¹ / ₂ "	FW12C302672-0_0_	72"
25 ¹ / ₂ "	FW12C302678-0_0_	78"
25 ¹ / ₂ "	FW12C302684-0_0_	84"
25 ¹ / ₂ "	FW12C302690-0_0_	90"
25 ¹ / ₂ "	FW12C302696-0_0_	96"
32"	FW12C303254-0_0_	54"
32"	FW12C303260-0_0_	60"
32"	FW12C303266-0_0_	66"
32"	FW12C303272-0_0_	72"
32"	FW12C303278-0_0_	78"
32"	FW12C303284-0_0_	84"
32"	FW12C303290-0_0_	90"
32"	FW12C303296-0_0_	96"

Double-sided Wood Cabinets

Depth	Wood Cabinet	Length
24"	FW12W302454-00_0_	54"
24"	FW12W302460-00_0_	60"
24"	FW12W302466-00_0_	66"
24"	FW12W302472-00_0_	72"
24"	FW12W302478-00_0_	78"
24"	FW12W302484-00_0_	84"
24"	FW12W302490-00_0_	90"
24"	FW12W302496-00_0_	96"
32"	FW12W303254-00_0_	54"
32"	FW12W303260-00_0_	60"
32"	FW12W303266-00_0_	66"
32"	FW12W303272-00_0_	72"
32"	FW12W303278-00_0_	78"
32"	FW12W303284-00_0_	84"
32"	FW12W303290-00_0_	90"
32"	FW12W303296-00_0_	96"

Upper Storage Cabinets

Upper Storage Cabinets are used in place of open shelving when enclosed storage and/or resistance to dust is required. Cabinets are available in powder coated steel or hardwood veneer plywood construction, and in a variety of door styles. All Evolution upper cabinets are 30" high and include two adjustable shelves. Double-sided cabinets use two single-sided cabinets mounted back-to-back on a single support assembly. Cabinets

mount between columns and include support assembly and mounting hardware. Add **-09** or **-12** to end of part number to indicate column depth of supporting module.

Note: Last four digits of part number designates cabinet/door style and hardware selection. See page 38 for full explanation. Actual product may vary slightly from catalog illustration due to style and hardware selection.

Swinging Glazed Door Cabinets

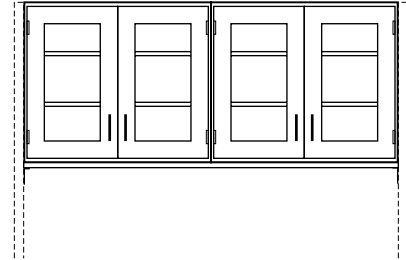
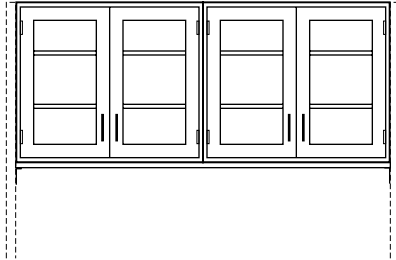

Single-sided Steel Cabinets

Depth	Steel Cabinet	Length
12 ³ / ₄ "	FW50C301354-	54"
12 ³ / ₄ "	FW50C301360-	60"
12 ³ / ₄ "	FW50C301366-	66"
12 ³ / ₄ "	FW50C301372-	72"
12 ³ / ₄ "	FW50C301378-	78"
12 ³ / ₄ "	FW50C301384-	84"
12 ³ / ₄ "	FW50C301390-	90"
12 ³ / ₄ "	FW50C301396-	96"
16"	FW50C301654-	54"
16"	FW50C301660-	60"
16"	FW50C301666-	66"
16"	FW50C301672-	72"
16"	FW50C301678-	78"
16"	FW50C301684-	84"
16"	FW50C301690-	90"
16"	FW50C301696-	96"

Single-sided Wood Cabinets

Depth	Wood Cabinet	Length
12"	FW20W301254-	54"
12"	FW20W301260-	60"
12"	FW20W301266-	66"
12"	FW20W301272-	72"
12"	FW20W301278-	78"
12"	FW20W301284-	84"
12"	FW20W301290-	90"
12"	FW20W301296-	96"
16"	FW20W301654-	54"
16"	FW20W301660-	60"
16"	FW20W301666-	66"
16"	FW20W301672-	72"
16"	FW20W301678-	78"
16"	FW20W301684-	84"
16"	FW20W301690-	90"
16"	FW20W301696-	96"

Double-sided Steel Cabinets

Depth	Steel Cabinet	Length
25 ¹ / ₂ "	FW50C302654-	54"
25 ¹ / ₂ "	FW50C302660-	60"
25 ¹ / ₂ "	FW50C302666-	66"
25 ¹ / ₂ "	FW50C302672-	72"
25 ¹ / ₂ "	FW50C302678-	78"
25 ¹ / ₂ "	FW50C302684-	84"
25 ¹ / ₂ "	FW50C302690-	90"
25 ¹ / ₂ "	FW50C302696-	96"
32"	FW50C303254-	54"
32"	FW50C303260-	60"
32"	FW50C303266-	66"
32"	FW50C303272-	72"
32"	FW50C303278-	78"
32"	FW50C303284-	84"
32"	FW50C303290-	90"
32"	FW50C303296-	96"

Double-sided Wood Cabinets

Depth	Wood Cabinet	Length
24"	FW20W302454-	54"
24"	FW20W302460-	60"
24"	FW20W302466-	66"
24"	FW20W302472-	72"
24"	FW20W302478-	78"
24"	FW20W302484-	84"
24"	FW20W302490-	90"
24"	FW20W302496-	96"
32"	FW20W303254-	54"
32"	FW20W303260-	60"
32"	FW20W303266-	66"
32"	FW20W303272-	72"
32"	FW20W303278-	78"
32"	FW20W303284-	84"
32"	FW20W303290-	90"
32"	FW20W303296-	96"

Upper Storage Cabinets

Upper Storage Cabinets are used in place of open shelving when enclosed storage and/or resistance to dust is required. Cabinets are available in powder coated steel or hardwood veneer plywood construction, and in a variety of door styles. All Evolution upper cabinets are 30" high and include two adjustable shelves. Double-sided cabinets use two single-sided cabinets mounted back-to-back on a single support assembly. Cabinets mount

between columns and include support assembly and mounting hardware. Add **-09** or **-12** to end of part number to indicate column depth of supporting module.

Note: Last four digits of part number designates cabinet/door style and hardware selection. See page 38 for full explanation. Actual product may vary slightly from catalog illustration due to style and hardware selection.

Swinging Panel Door Cabinets

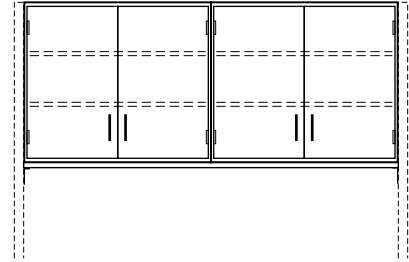
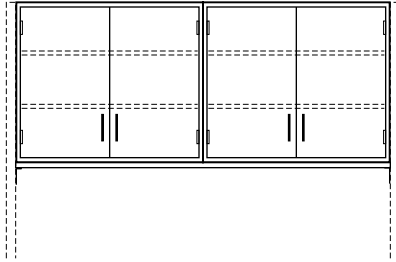

Single-sided Steel Cabinets

Depth	Steel Cabinet	Length
12 ³ / ₄ "	FW25C301354-	54"
12 ³ / ₄ "	FW25C301360-	60"
12 ³ / ₄ "	FW25C301366-	66"
12 ³ / ₄ "	FW25C301372-	72"
12 ³ / ₄ "	FW25C301378-	78"
12 ³ / ₄ "	FW25C301384-	84"
12 ³ / ₄ "	FW25C301390-	90"
12 ³ / ₄ "	FW25C301396-	96"
16"	FW25C301654-	54"
16"	FW25C301660-	60"
16"	FW25C301666-	66"
16"	FW25C301672-	72"
16"	FW25C301678-	78"
16"	FW25C301684-	84"
16"	FW25C301690-	90"
16"	FW25C301696-	96"

Single-sided Wood Cabinets

Depth	Wood Cabinet	Length
12"	FW25W301254-	54"
12"	FW25W301260-	60"
12"	FW25W301266-	66"
12"	FW25W301272-	72"
12"	FW25W301278-	78"
12"	FW25W301284-	84"
12"	FW25W301290-	90"
12"	FW25W301296-	96"
16"	FW25W301654-	54"
16"	FW25W301660-	60"
16"	FW25W301666-	66"
16"	FW25W301672-	72"
16"	FW25W301678-	78"
16"	FW25W301684-	84"
16"	FW25W301690-	90"
16"	FW25W301696-	96"

Double-sided Steel Cabinets

Depth	Steel Cabinet	Length
25 ¹ / ₂ "	FW25C302654-	54"
25 ¹ / ₂ "	FW25C302660-	60"
25 ¹ / ₂ "	FW25C302666-	66"
25 ¹ / ₂ "	FW25C302672-	72"
25 ¹ / ₂ "	FW25C302678-	78"
25 ¹ / ₂ "	FW25C302684-	84"
25 ¹ / ₂ "	FW25C302690-	90"
25 ¹ / ₂ "	FW25C302696-	96"
32"	FW25C303254-	54"
32"	FW25C303260-	60"
32"	FW25C303266-	66"
32"	FW25C303272-	72"
32"	FW25C303278-	78"
32"	FW25C303284-	84"
32"	FW25C303290-	90"
32"	FW25C303296-	96"

Double-sided Wood Cabinets

Depth	Wood Cabinet	Length
24"	FW25W302454-	54"
24"	FW25W302460-	60"
24"	FW25W302466-	66"
24"	FW25W302472-	72"
24"	FW25W302478-	78"
24"	FW25W302484-	84"
24"	FW25W302490-	90"
24"	FW25W302496-	96"
32"	FW25W303254-	54"
32"	FW25W303260-	60"
32"	FW25W303266-	66"
32"	FW25W303272-	72"
32"	FW25W303278-	78"
32"	FW25W303284-	84"
32"	FW25W303290-	90"
32"	FW25W303296-	96"

Pass-thru Upper Storage Cabinets

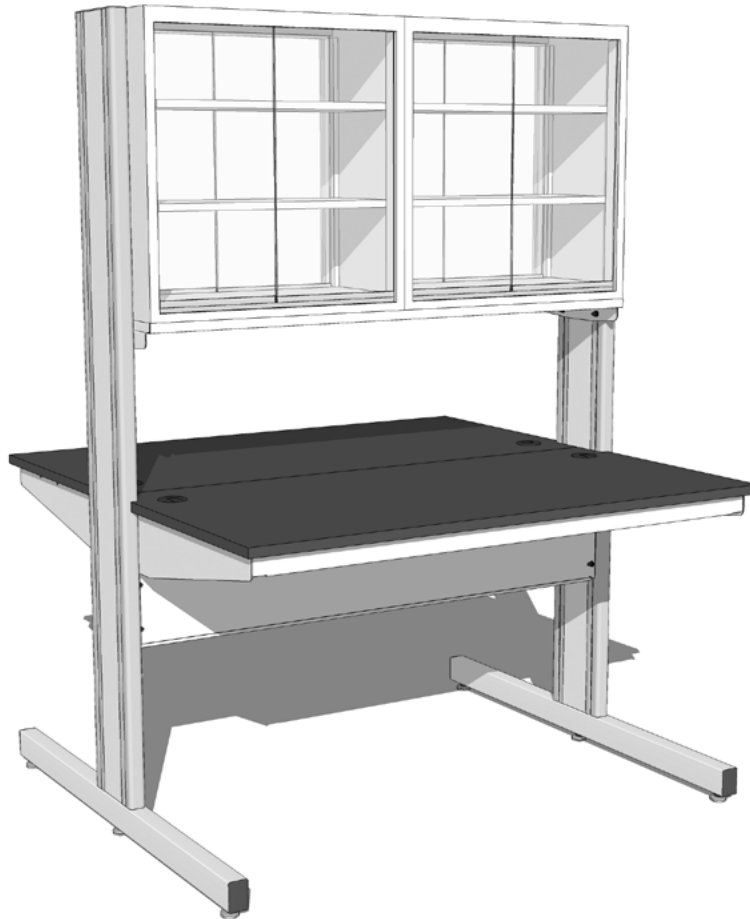

Sliding Plate Glass Door Cabinets

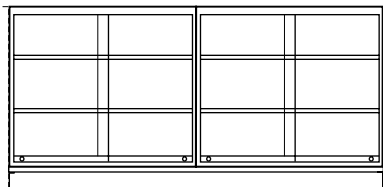

Depth	Steel Cabinet	Length
16"	FW13C301654-00_0	54"
16"	FW13C301660-00_0	60"
16"	FW13C301666-00_0	66"
16"	FW13C301672-00_0	72"
16"	FW13C301678-00_0	78"
16"	FW13C301684-00_0	84"
16"	FW13C301690-00_0	90"
16"	FW13C301696-00_0	96"
22"	FW13C302254-00_0	54"
22"	FW13C302260-00_0	60"
22"	FW13C302266-00_0	66"
22"	FW13C302272-00_0	72"
22"	FW13C302278-00_0	78"
22"	FW13C302284-00_0	84"
22"	FW13C302290-00_0	90"
22"	FW13C302296-00_0	96"

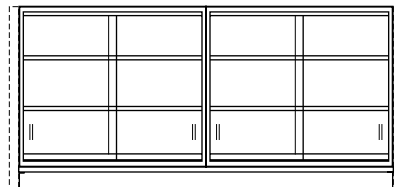

Depth	Wood Cabinet	Length
16"	FW13W301654-00_0	54"
16"	FW13W301660-00_0	60"
16"	FW13W301666-00_0	66"
16"	FW13W301672-00_0	72"
16"	FW13W301678-00_0	78"
16"	FW13W301684-00_0	84"
16"	FW13W301690-00_0	90"
16"	FW13W301696-00_0	96"
22"	FW13W302254-00_0	54"
22"	FW13W302260-00_0	60"
22"	FW13W302266-00_0	66"
22"	FW13W302272-00_0	72"
22"	FW13W302278-00_0	78"
22"	FW13W302284-00_0	84"
22"	FW13W302290-00_0	90"
22"	FW13W302296-00_0	96"

Illustrations and specifications are based on most current design and production information available. Kewaunee reserves the right to make changes at any time without notice.

Pass-thru Upper Storage Cabinets

Pass-thru Upper Storage Cabinets are used in place of open shelving when enclosed storage and/or resistance to dust is required. Cabinets are available in powder coated steel or hardwood veneer plywood construction, and in a variety of door styles. All Evolution upper cabinets are 30" high and include two adjustable shelves. Cabinets mount between columns and include support assembly and mounting hardware. Add **-09** or **-12** to end

of part number to indicate column depth of supporting module.

Note: Last four digits of part number designates cabinet/door style and hardware selection. See page 38 for full explanation. Actual product may vary slightly from catalog illustration due to style and hardware selection.

Sliding Glazed Door Cabinets

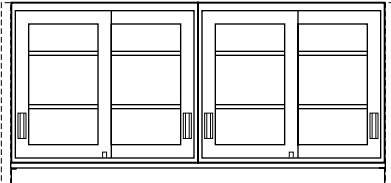

Depth	Steel Cabinet	Length
16"	FW44C301654-0_0_	54"
16"	FW44C301660-0_0_	60"
16"	FW44C301666-0_0_	66"
16"	FW44C301672-0_0_	72"
16"	FW44C301678-0_0_	78"
16"	FW44C301684-0_0_	84"
16"	FW44C301690-0_0_	90"
16"	FW44C301696-0_0_	96"
22"	FW44C302254-0_0_	54"
22"	FW44C302260-0_0_	60"
22"	FW44C302266-0_0_	66"
22"	FW44C302272-0_0_	72"
22"	FW44C302278-0_0_	78"
22"	FW44C302284-0_0_	84"
22"	FW44C302290-0_0_	90"
22"	FW44C302296-0_0_	96"

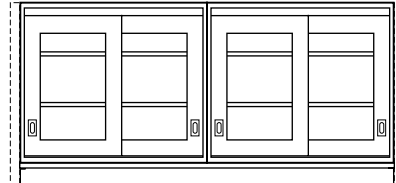

Depth	Wood Cabinet	Length
16"	FW14W301654-00_0_	54"
16"	FW14W301660-00_0_	60"
16"	FW14W301666-00_0_	66"
16"	FW14W301672-00_0_	72"
16"	FW14W301678-00_0_	78"
16"	FW14W301684-00_0_	84"
16"	FW14W301690-00_0_	90"
16"	FW14W301696-00_0_	96"
22"	FW14W302254-00_0_	54"
22"	FW14W302260-00_0_	60"
22"	FW14W302266-00_0_	66"
22"	FW14W302272-00_0_	72"
22"	FW14W302278-00_0_	78"
22"	FW14W302284-00_0_	84"
22"	FW14W302290-00_0_	90"
22"	FW14W302296-00_0_	96"

Sliding Panel Door Cabinets

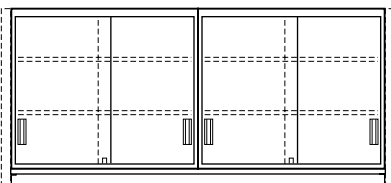

Depth	Steel Cabinet	Length
16"	FW15C301654-0_0_	54"
16"	FW15C301660-0_0_	60"
16"	FW15C301666-0_0_	66"
16"	FW15C301672-0_0_	72"
16"	FW15C301678-0_0_	78"
16"	FW15C301684-0_0_	84"
16"	FW15C301690-0_0_	90"
16"	FW15C301696-0_0_	96"
22"	FW15C302254-0_0_	54"
22"	FW15C302260-0_0_	60"
22"	FW15C302266-0_0_	66"
22"	FW15C302272-0_0_	72"
22"	FW15C302278-0_0_	78"
22"	FW15C302284-0_0_	84"
22"	FW15C302290-0_0_	90"
22"	FW15C302296-0_0_	96"

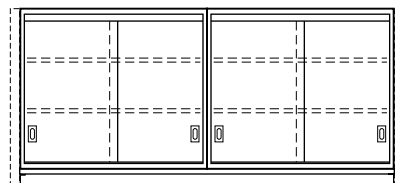

Depth	Wood Cabinet	Length
16"	FW15W301654-00_0_	54"
16"	FW15W301660-00_0_	60"
16"	FW15W301666-00_0_	66"
16"	FW15W301672-00_0_	72"
16"	FW15W301678-00_0_	78"
16"	FW15W301684-00_0_	84"
16"	FW15W301690-00_0_	90"
16"	FW15W301696-00_0_	96"
22"	FW15W302254-00_0_	54"
22"	FW15W302260-00_0_	60"
22"	FW15W302266-00_0_	66"
22"	FW15W302272-00_0_	72"
22"	FW15W302278-00_0_	78"
22"	FW15W302284-00_0_	84"
22"	FW15W302290-00_0_	90"
22"	FW15W302296-00_0_	96"

Pass-thru Upper Storage Cabinets

Pass-thru Upper Storage Cabinets are used in place of open shelving when enclosed storage and/or resistance to dust is required. Cabinets are available in powder coated steel or hardwood veneer plywood construction, and in a variety of door styles. All Evolution upper cabinets are 30" high and include two adjustable shelves. Cabinets mount between columns and include support assembly and mounting hardware. Add **-09** or **-12** to end

of part number to indicate column depth of supporting module.

Note: Last four digits of part number designates cabinet/door style and hardware selection. See page 38 for full explanation. Actual product may vary slightly from catalog illustration due to style and hardware selection.

Swinging Glazed Door Cabinets

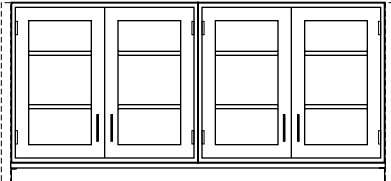

Depth	Steel Cabinet	Length
16"	FW53C301654-	54"
16"	FW53C301660-	60"
16"	FW53C301666-	66"
16"	FW53C301672-	72"
16"	FW53C301678-	78"
16"	FW53C301684-	84"
16"	FW53C301690-	90"
16"	FW53C301696-	96"
22"	FW53C302254-	54"
22"	FW53C302260-	60"
22"	FW53C302266-	66"
22"	FW53C302272-	72"
22"	FW53C302278-	78"
22"	FW53C302284-	84"
22"	FW53C302290-	90"
22"	FW53C302296-	96"

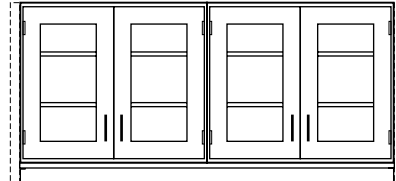

Depth	Wood Cabinet	Length
16"	FW23W301654-	54"
16"	FW23W301660-	60"
16"	FW23W301666-	66"
16"	FW23W301672-	72"
16"	FW23W301678-	78"
16"	FW23W301684-	84"
16"	FW23W301690-	90"
16"	FW23W301696-	96"
22"	FW23W302254-	54"
22"	FW23W302260-	60"
22"	FW23W302266-	66"
22"	FW23W302272-	72"
22"	FW23W302278-	78"
22"	FW23W302284-	84"
22"	FW23W302290-	90"
22"	FW23W302296-	96"

Swinging Panel Door Cabinets

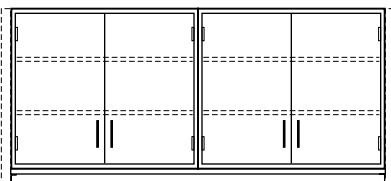

Depth	Steel Cabinet	Length
16"	FW28C301654-	54"
16"	FW28C301660-	60"
16"	FW28C301666-	66"
16"	FW28C301672-	72"
16"	FW28C301678-	78"
16"	FW28C301684-	84"
16"	FW28C301690-	90"
16"	FW28C301696-	96"
22"	FW28C302254-	54"
22"	FW28C302260-	60"
22"	FW28C302266-	66"
22"	FW28C302272-	72"
22"	FW28C302278-	78"
22"	FW28C302284-	84"
22"	FW28C302290-	90"
22"	FW28C302296-	96"

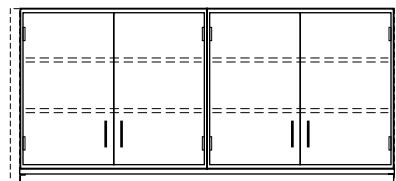

Depth	Wood Cabinet	Length
16"	FW28W301654-	54"
16"	FW28W301660-	60"
16"	FW28W301666-	66"
16"	FW28W301672-	72"
16"	FW28W301678-	78"
16"	FW28W301684-	84"
16"	FW28W301690-	90"
16"	FW28W301696-	96"
22"	FW28W302254-	54"
22"	FW28W302260-	60"
22"	FW28W302266-	66"
22"	FW28W302272-	72"
22"	FW28W302278-	78"
22"	FW28W302284-	84"
22"	FW28W302290-	90"
22"	FW28W302296-	96"

Illustrations and specifications are based on most current design and production information available. Kewaunee reserves the right to make changes at any time without notice.

Ceiling Service Panel

Features:

- Designed to integrate into common ceiling grids for delivering plumbing, electrical, and data services to the lab bench
- Fits in standard 2' x 2' and 2' x 4' ceiling grids
- Electrical devices are UL listed.
- Available in all standard powder coat finish colors
- May be customized to meet your project requirements
- Accommodates multiple lab services including:
 - Common gases, air, vacuum, and water
 - High purity and special gases
 - Power and data
- Accepts multiple fitting options including:
 - Standard or fine control valves
 - Pressure gauges and regulators
 - Quick-connect fittings
 - Communication and data outlets
 - Electrical service outlets

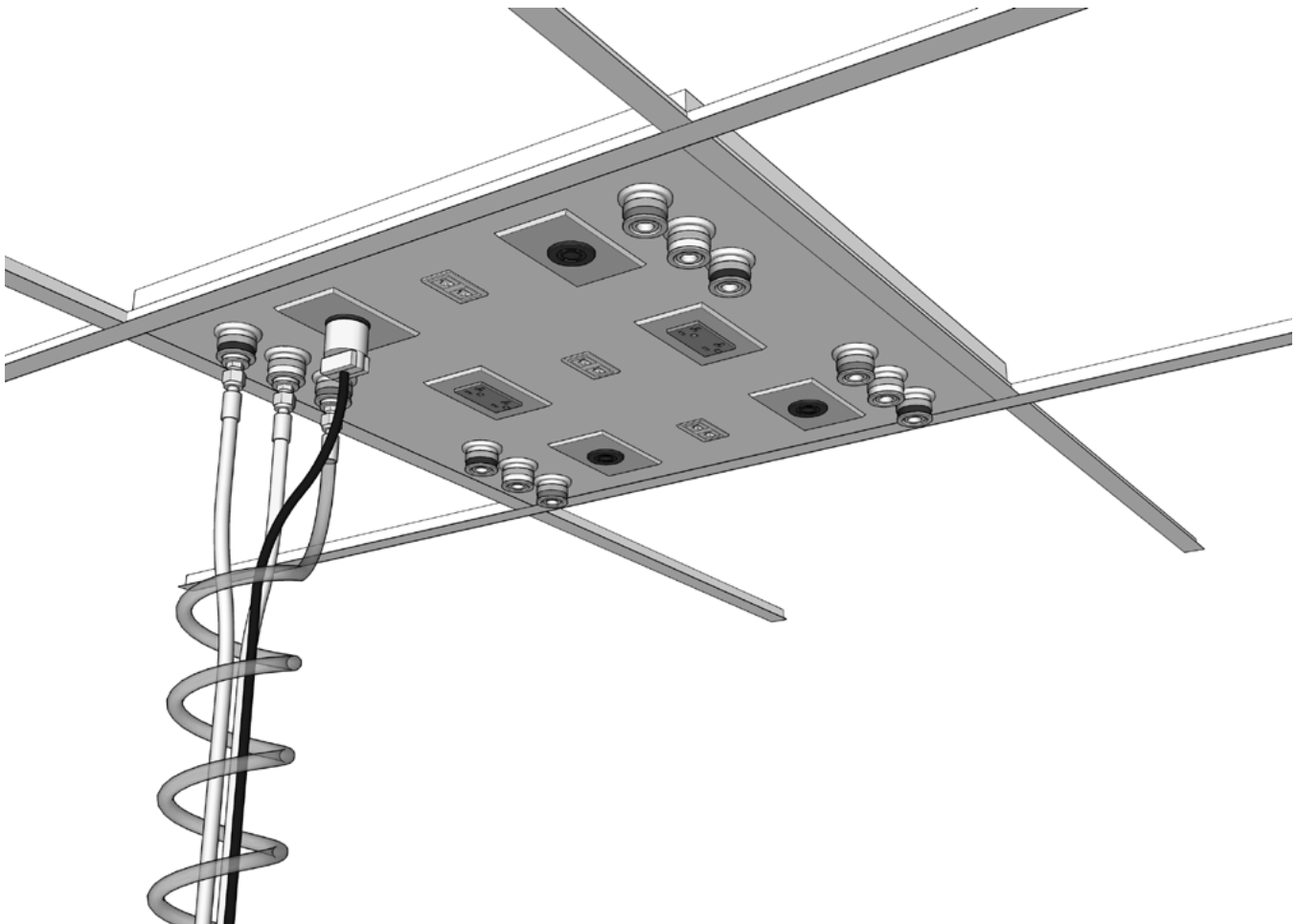

Ceiling Service Panel & Accessories

Ceiling Service Panels are fabricated from powder coat 12 gauge steel in two sizes to fit standard ceiling grid. They can be punched to accept most electrical, data, or service fittings. **Fittings and Fixtures must be ordered separately**

Electrical Fixtures are furnished complete with device, box and cover plate and are supplied loose, uninstalled.

Power Cords are required to carry power from the overhead service carriers to the support frame. The SJ 12/3 and SJ 12/4 cords are available in various configurations.

24" x 24" Ceiling Service Panel

24" x 48" Ceiling Service Panel

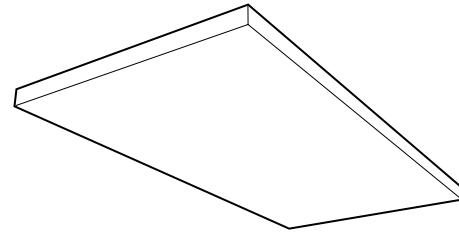
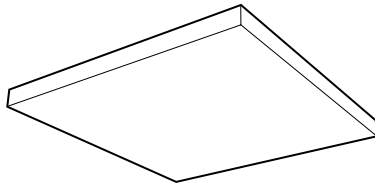

Part Number	Dimensions (HxDxL)
SC10M022424-00	1 ¹ / ₂ " x 24" x 24"

Part Number	Dimensions (HxDxL)
SC10M022448-00	1 ¹ / ₂ " x 24" x 48"

Electrical Fixtures

Power Cords

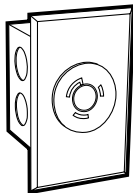

Twist-lock Single-circuit 20 amp

0620-1K Black
NEMA L5-20 3-wire, specification grade, 120 VAC, 20 amp, single receptacle.

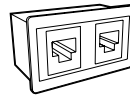

RJ45 8P8C Data/Comm Outlet

0720-0K-6 Cat-6 Black
0720-0V-6 Cat-6 Ivory
0720-0K-6a Cat-6a Black
0720-0V-6a Cat-6a Ivory

(2) RJ45 8P8C Outlets
Fits in 1¹/₄" x 2" cutout.

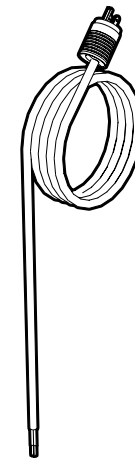

Single-circuit 3-wire

120 VAC — 20A — NEMA L5-20

Part Number	Length	Plug Type
W-5622-36	36"ATOP	Twist-Lock
W-5622-48	48"ATOP	Twist-Lock
W-5622-60	60"ATOP	Twist-Lock
W-5622-72	72"ATOP	Twist-Lock
W-5622-96	96"ATOP	Twist-Lock

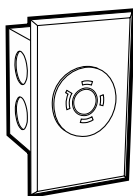

Dual-circuit Twist-lock 20 amp

0624-1K Black
NEMA L14-20 4-wire, specification grade receptacle. Capable of carrying two 120 VAC, 20 amp circuits.

Note: Check local electrical codes for compliance.

Dual-circuit 4-wire

120 VAC — 20A — NEMA L14-20

Part Number	Length	Plug Type
W-5624-36	36"ATOP	Twist-Lock
W-5624-48	48"ATOP	Twist-Lock
W-5624-60	60"ATOP	Twist-Lock
W-5624-72	72"ATOP	Twist-Lock
W-5624-96	96"ATOP	Twist-Lock

Ceiling Service Panel Accessories

Service Hoses are required to carry services from overhead service panel to the workstation column. They are available in reinforced PVC, polyurethane, or braided stainless steel. PVC hoses are available in 9 colors to match quick-connect color codes.

Specify PVC hose color by placing color code at end of hose part number.

Example: W-1133-36-H2 for Orange hose

Extension Service Hoses

Hose/Cord Wrap

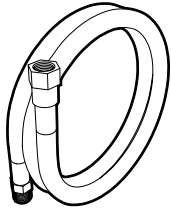

Reinforced PVC Hose

for Non-burning Gases
3/8" IPS Female Inlet
3/8" IPS Male Outlet

Length	Part Number
36"	W-1133-36-H
48"	W-1133-48-H
60"	W-1133-60-H
72"	W-1133-72-H
96"	W-1133-96-H

Braided Stainless Steel Hose

for Natural & Reactive Gases
3/8" IPS Female Inlet
3/8" IPS Male Outlet

Length	Part Number
36"	W-1233-36-H0
48"	W-1233-48-H0
60"	W-1233-60-H0
72"	W-1233-72-H0
96"	W-1233-96-H0

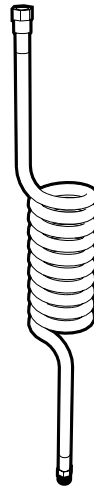

Coiled Polyurethane Hose

for Non-burning Gases
3/8" IPS Female Inlet
3/8" IPS Male Outlet

Length	Part Number
72"	W-1533-72

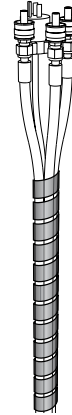

Poly Hose Wrap

Spiral wrap for bundling service lines and cords. Expandable from 1" to 2" diameter. May be trimmed to length with scissors.

L	Part Number	Color
36"	F-8250-36-BK	Black
36"	F-8250-36-NA	Natural
72"	F-8250-72-BK	Black
72"	F-8250-72-NA	Natural

Hose Colors

Color Code	Color	Color Code	Color
H1	Black	H6	White
H2	Orange	H7	Purple
H3	Green	H8	Brown
H4	Yellow	H9	Clear
H5	Blue		

Ceiling Service Panel Accessories

Keyed Quick-Connect Fittings are available for Hoses to ease service connection and disconnection during bench relocation. They are available in eight sizes (keys) which keeps service outlets from being connected to the wrong service.

Keyed Quick-connect Fittings

for use on
Service Hoses



**Male
Hose Mount**
3/8" IPS Male

Part Number	Key Color
W-8111-K1	Black
W-8111-K2	Orange
W-8111-K3	Green
W-8111-K4	Yellow
W-8111-K5	Blue
W-8111-K6	White
W-8111-K7	Purple
W-8111-K8	Brown

for use on
Service Hoses

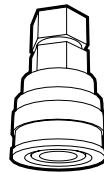

**Female
Hose Mount**
3/8" IPS Female

Part Number	Key Color
W-9112-K1	Black
W-9112-K2	Orange
W-9112-K3	Green
W-9112-K4	Yellow
W-9112-K5	Blue
W-9112-K6	White
W-9112-K7	Purple
W-9112-K8	Brown

for use on
Ceiling Service Panels

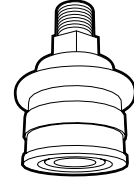

**Female
Panel Mount**
3/8" IPS Male

Part Number	Key Color
W-9122-K1	Black
W-9122-K2	Orange
W-9122-K3	Green
W-9122-K4	Yellow
W-9122-K5	Blue
W-9122-K6	White
W-9122-K7	Purple
W-9122-K8	Brown

Keyed Quick-connect Fittings

Key Number and Color Code	Standard Service	Female Body Sleeve Dia.		Male Body Sleeve Dia.	
		in.	mm	in.	mm
K1 Black	Helium	1.13	28.7	0.99	25.1
K2 Orange	Air	1.16	29.5	1.02	25.8
K3 Green	Water	1.19	30.2	1.05	26.6
K4 Yellow	Vacuum	1.22	31.0	1.08	27.4
K5 Blue	Gas	1.24	31.5	1.11	28.1
K6 White	—	1.28	32.5	1.14	28.9
K7 Purple	Argon	1.31	33.3	1.17	29.7
K8 Brown	Nitrogen	1.34	34.0	1.20	30.4

Technical Information

Dimensions - FV10 & FV11 Single-sided 9" Column Workstation on Glides

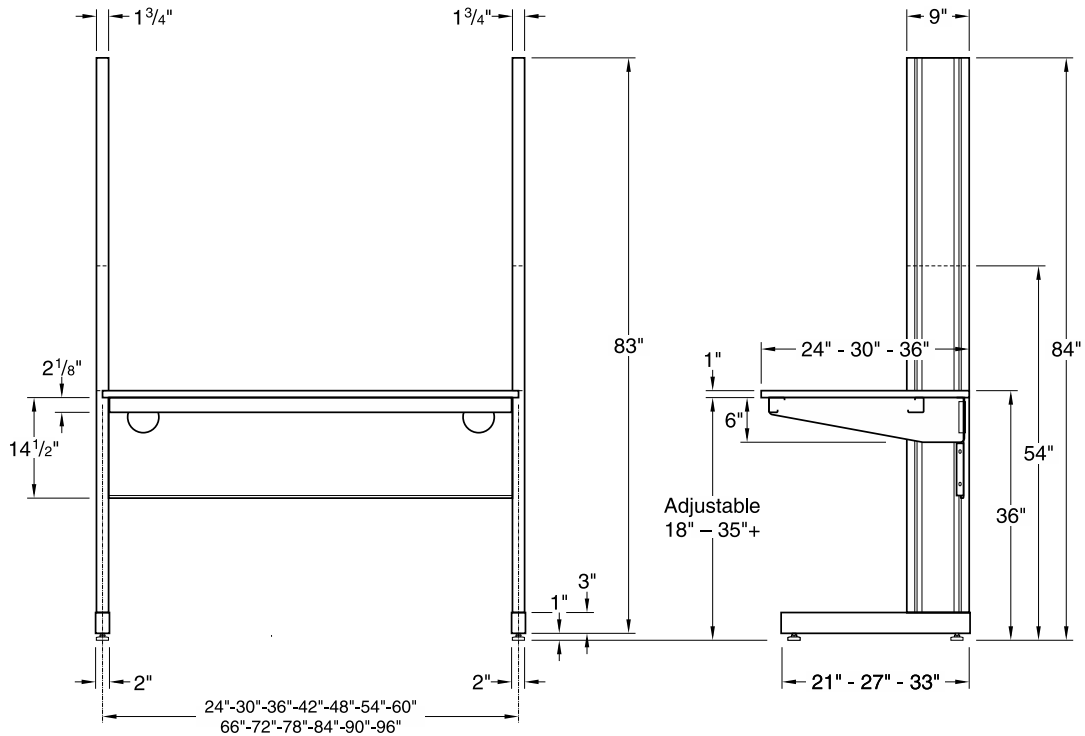

FV10MXXXXXX-00 Front Elevation

FV10MXXXXXX-00 End Elevation

Dimensions - FV10 & FV11 Single-sided 9" Column Workstation Casters

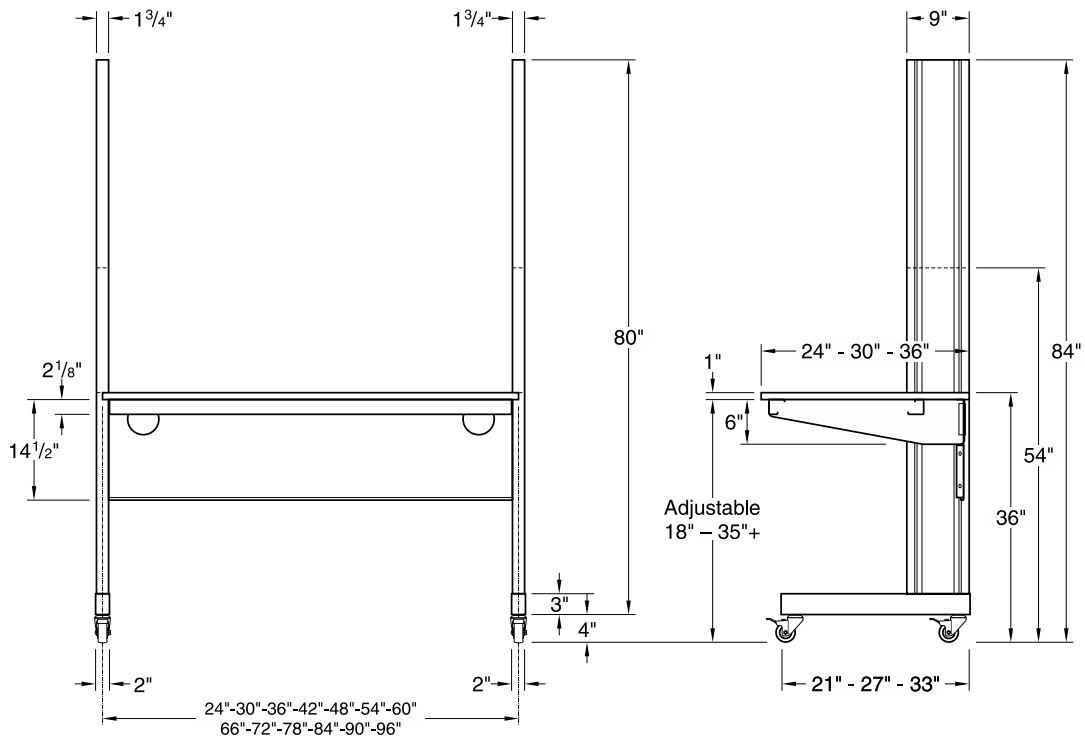

FV10MXXXXXX-01 & 02 Front Elevation

FV10MXXXXXX-01 & 02 End Elevation

Technical Information

Dimensions - FV30 & FV31 Single-sided 12" Column Workstation on Glides

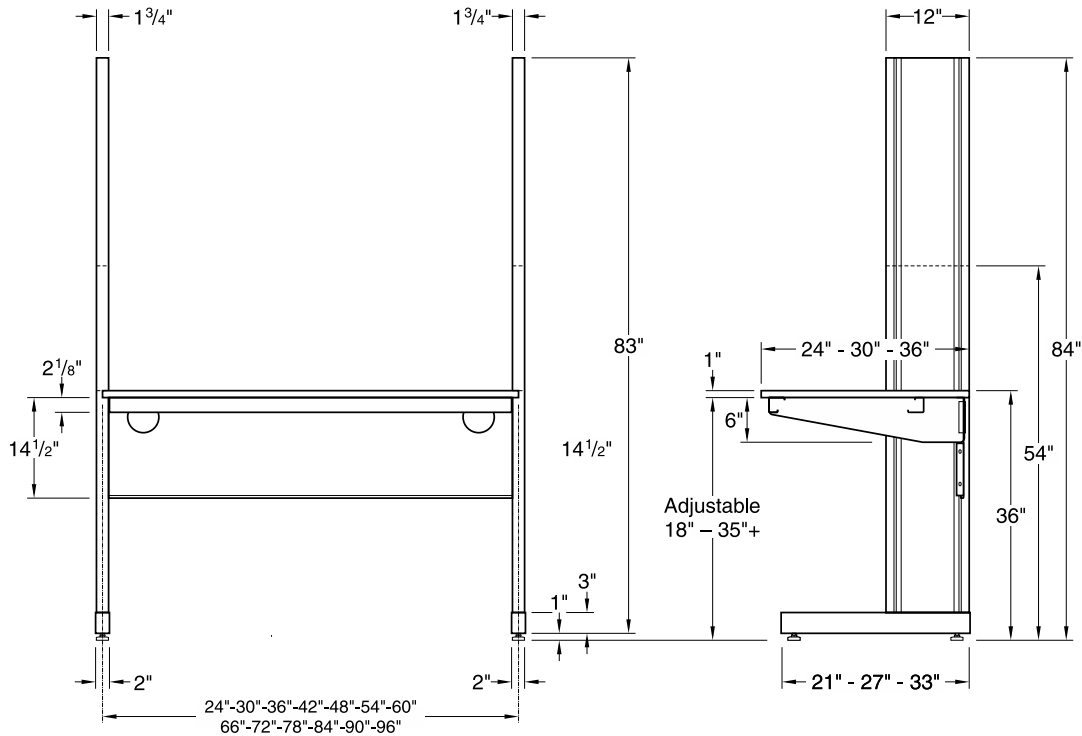

FV30MXXXXXX-00 Front Elevation

FV30MXXXXXX-00 End Elevation

Dimensions - FV30 & FV31 Single-sided 12" Column Workstation Casters

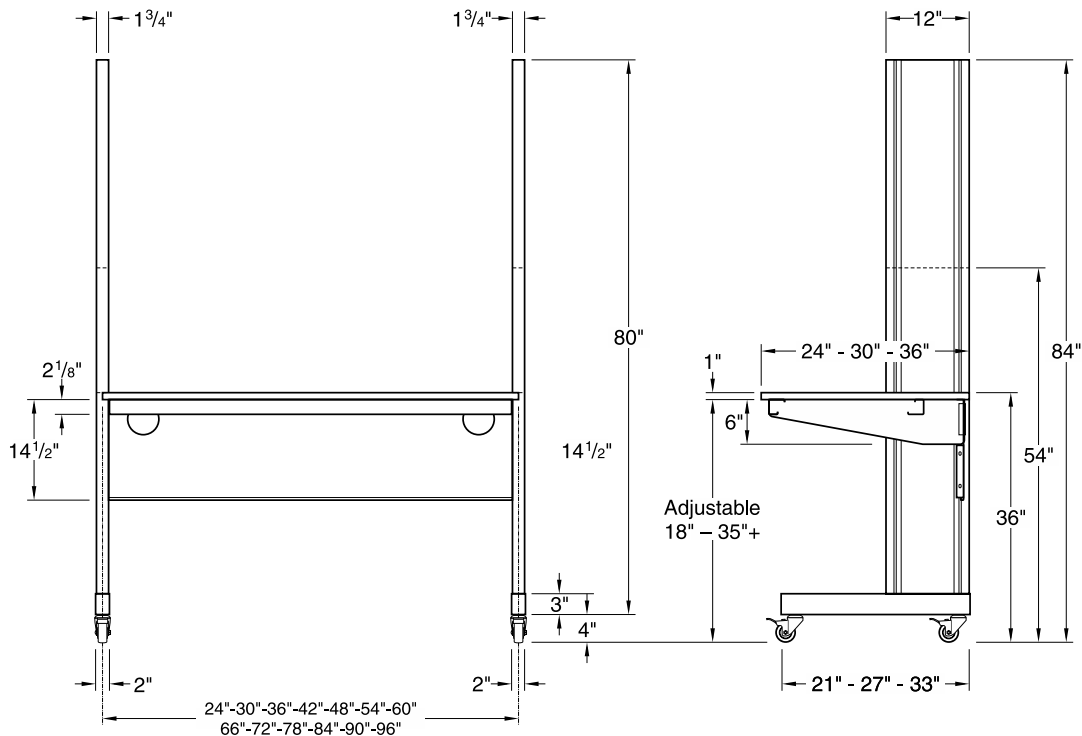

FV30MXXXXXX-01 & 02 Front Elevation

FV30MXXXXXX-01 & 02 End Elevation

Technical Information

Dimensions - FV20 & FV21 Double-sided 9" Column Workstation on Glides

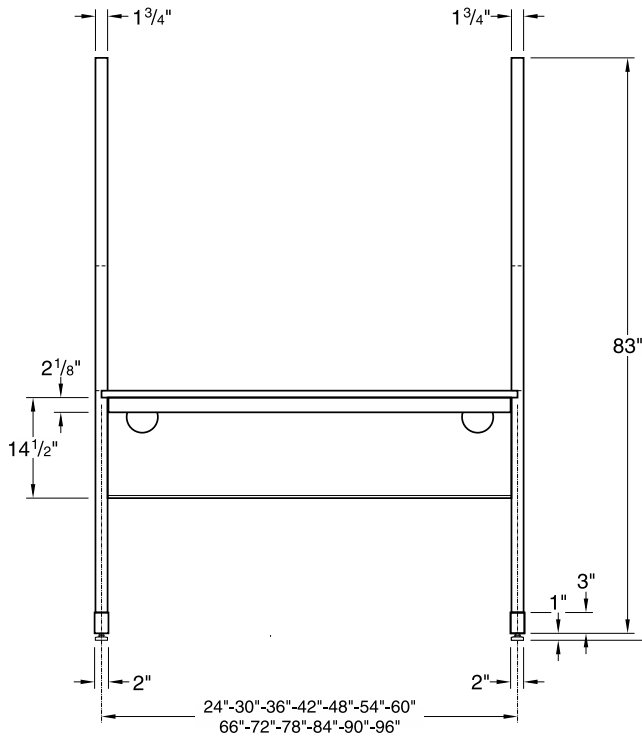

FV20MX00-00 Front Elevation

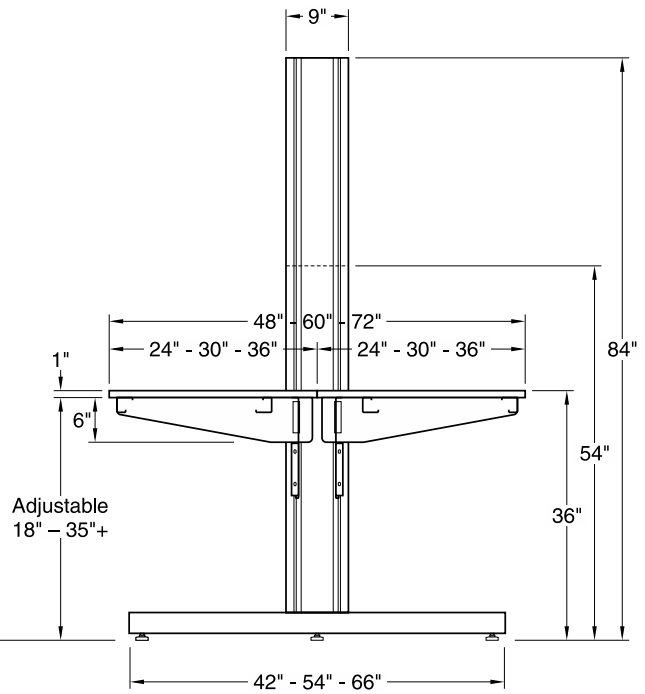

FV20MX00-00 End Elevation

Dimensions - FV20 & FV21 Double-sided 9" Column Workstation Casters

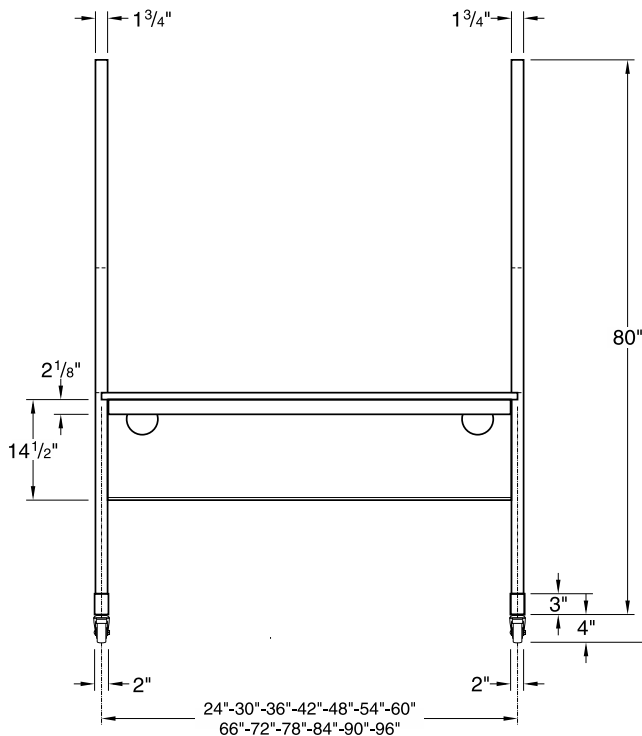

FV20MX01 & 02 Front Elevation

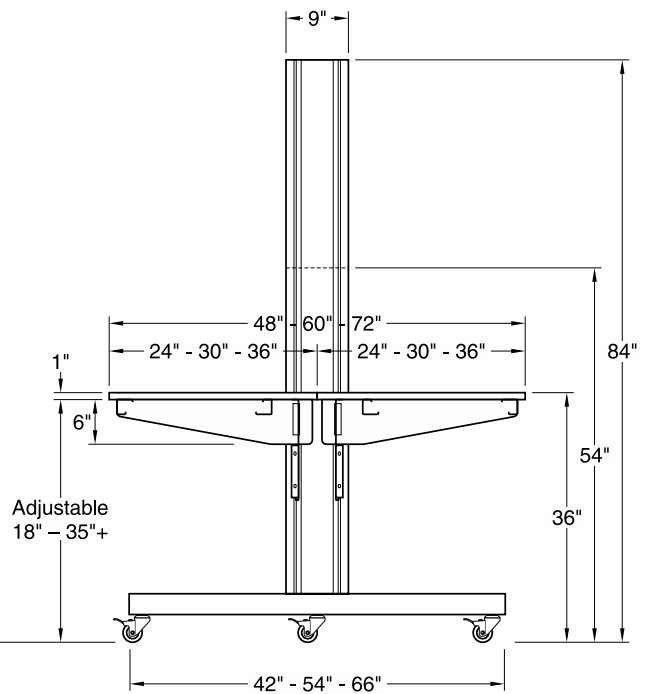

FV20MX01 & 02 End Elevation

Technical Information

Dimensions - FV40 & FV41 Double-sided 12" Column Workstation on Glides

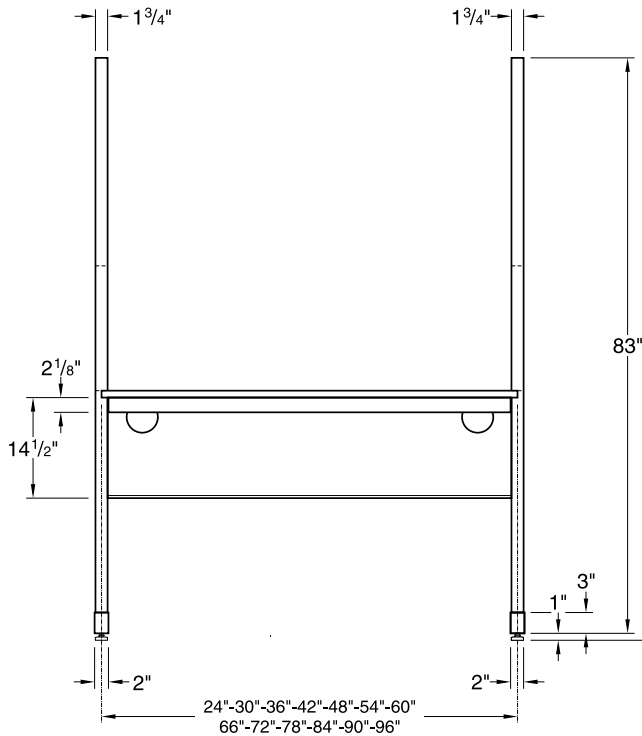

FV40MXXXXX-00 Front Elevation

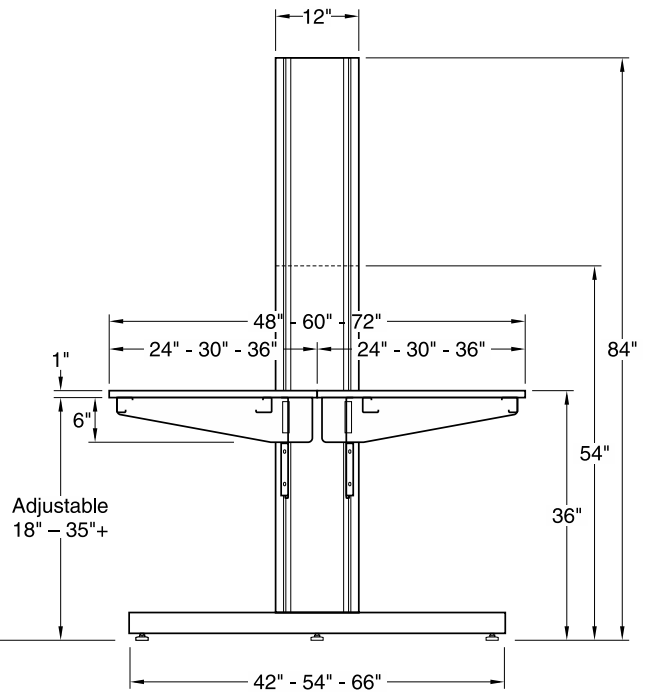

FV40MXXXXX-00 End Elevation

Dimensions - FV40 & FV41 Double-sided 12" Column Workstation Casters

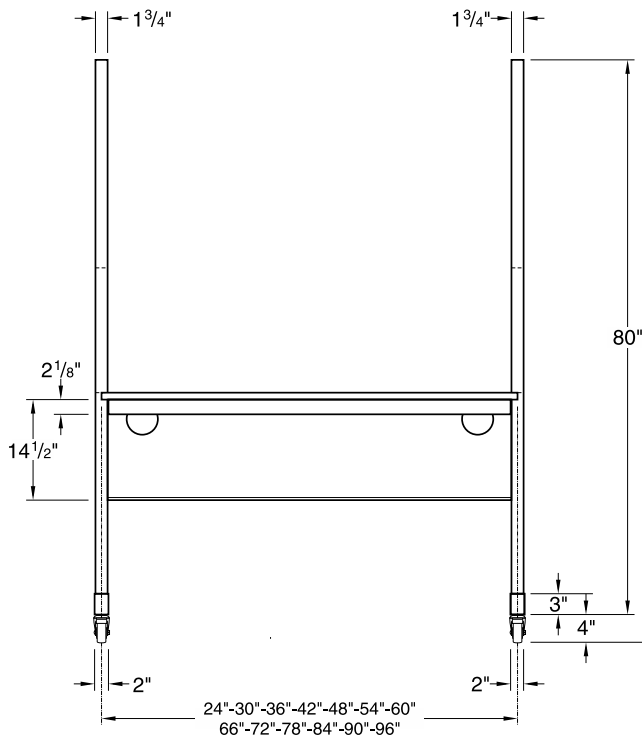

FV40MXXXXX-01 & 02 Front Elevation

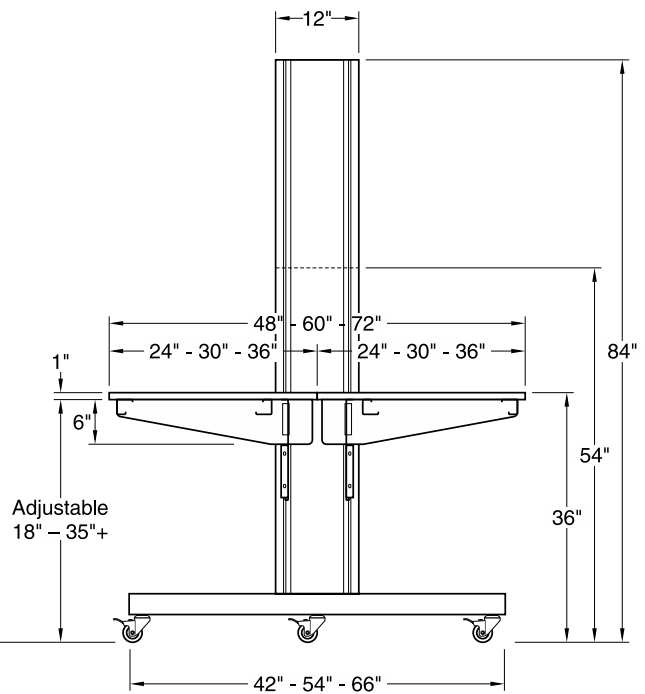

FV40MXXXXX-01 & 02 End Elevation

Technical Information

Dimensions - Single-sided Undermount Shelf Assemblies

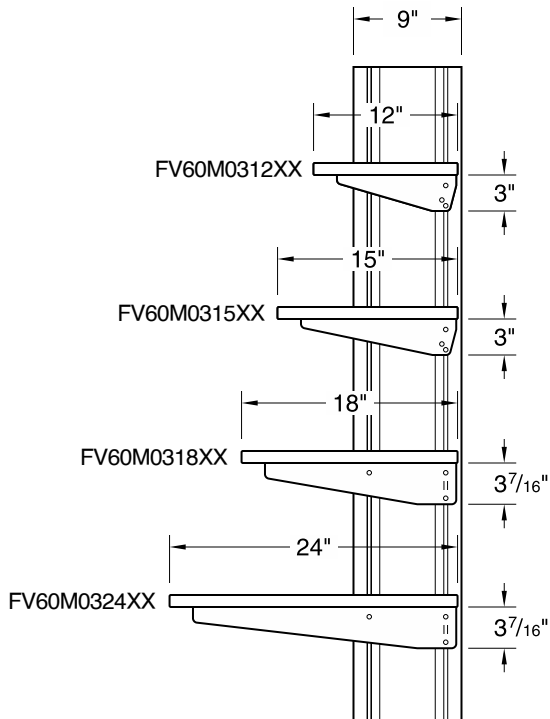

9" Column Section View

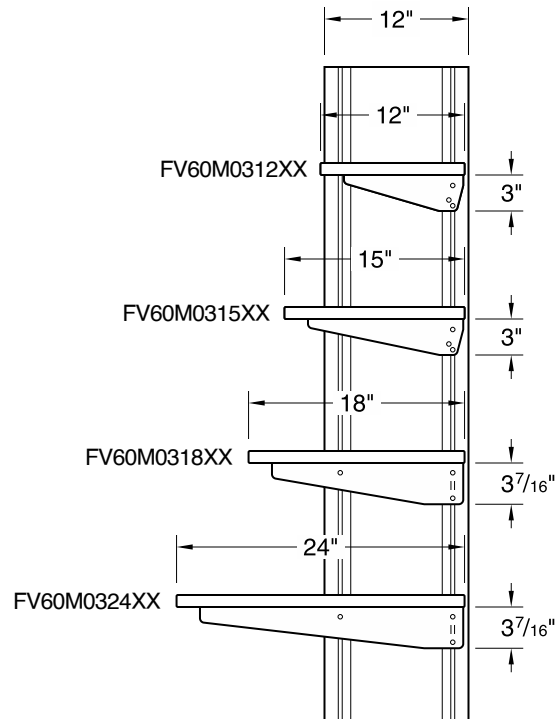

12" Column Section View

Dimensions - Single-sided Bookend Shelf Assemblies

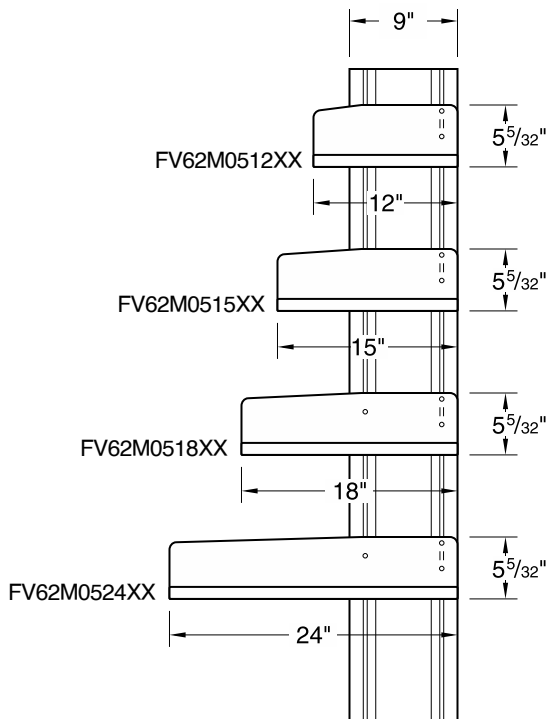

9" Column Section View

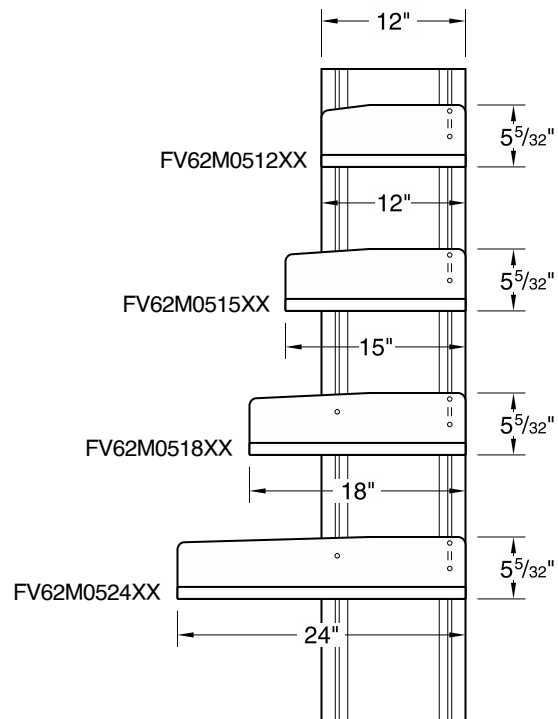

12" Column Section View

Technical Information

Dimensions - Double-sided Undermount Shelf Assemblies

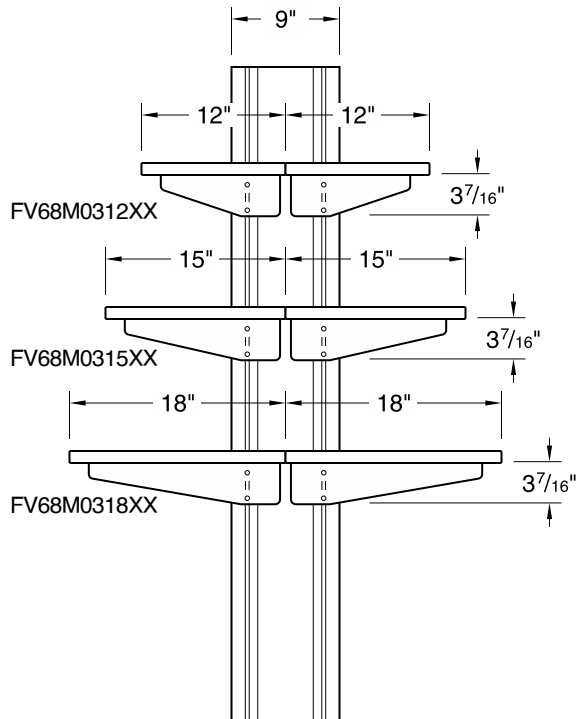

9" Column Section View

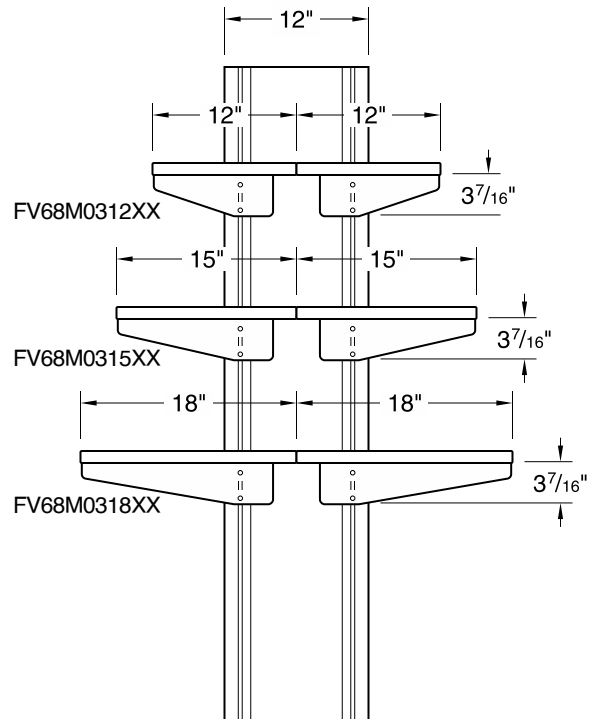

12" Column Section View

Dimensions - Double-sided Bookend Shelf Assemblies

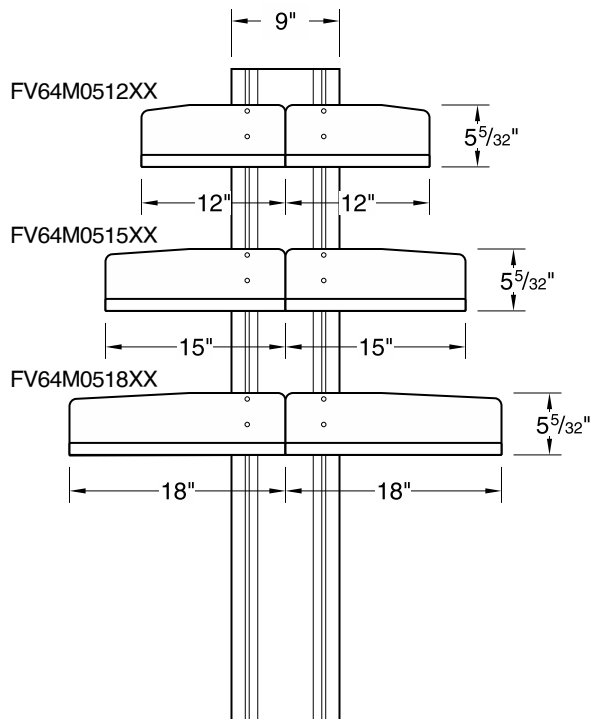

9" Column Section View

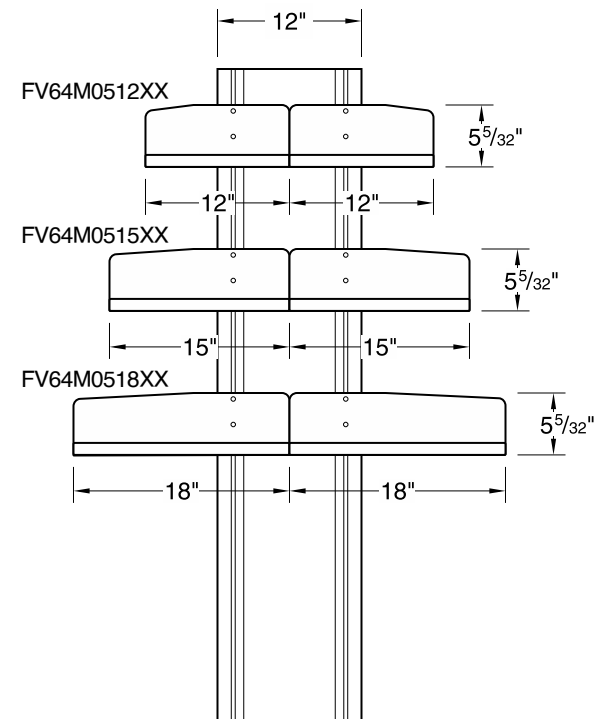

12" Column Section View

Technical Information

Dimensions - Center Undermount Shelf Assemblies

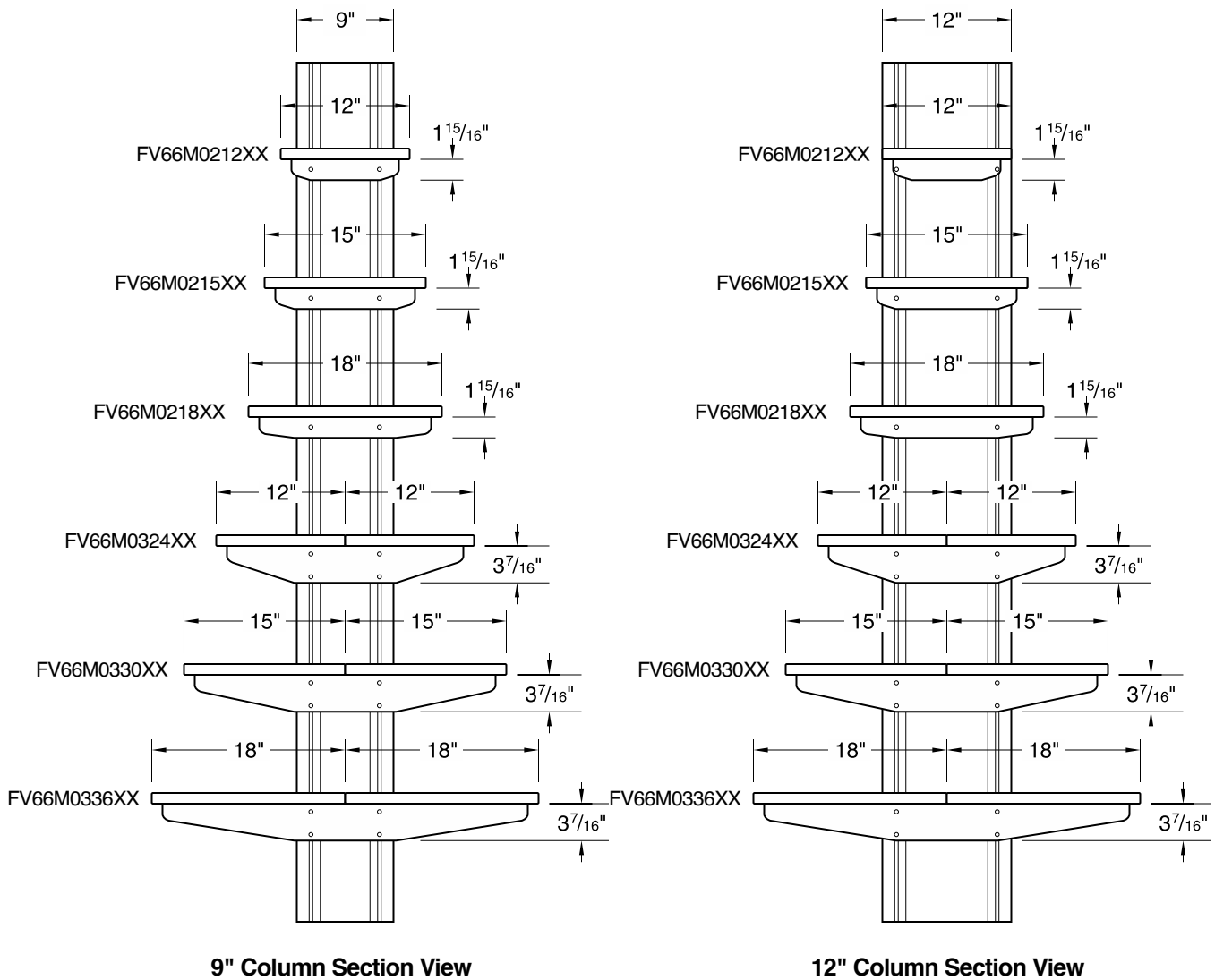

Dimensions - Back-to-Back Upper Storage Cabinets

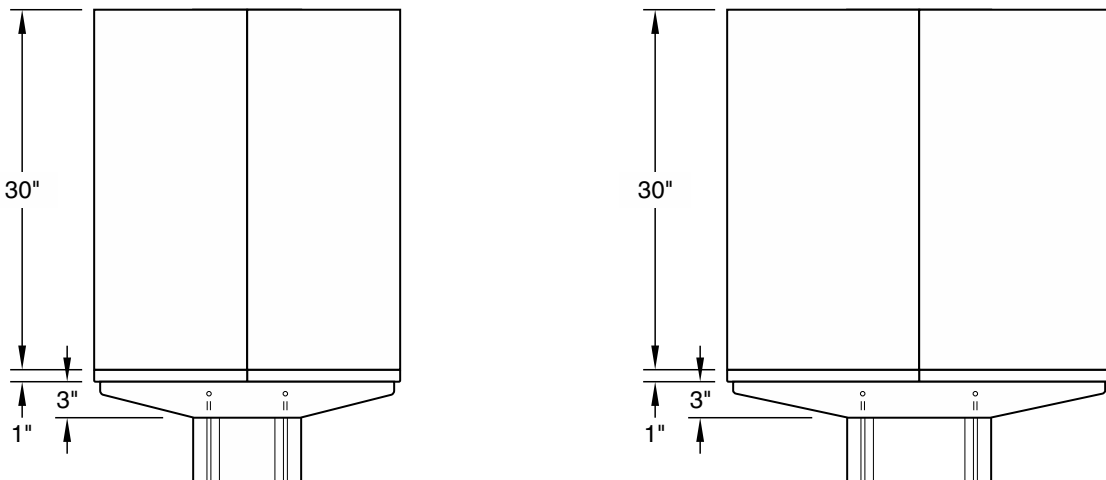

Technical Information

Dimensions - Upper Storage & Suspended Cabinets

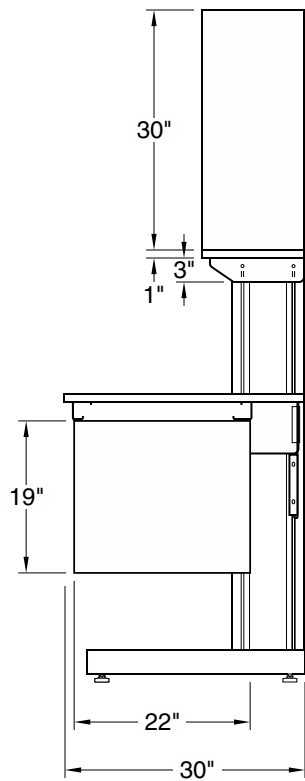

30" Deep Workstation

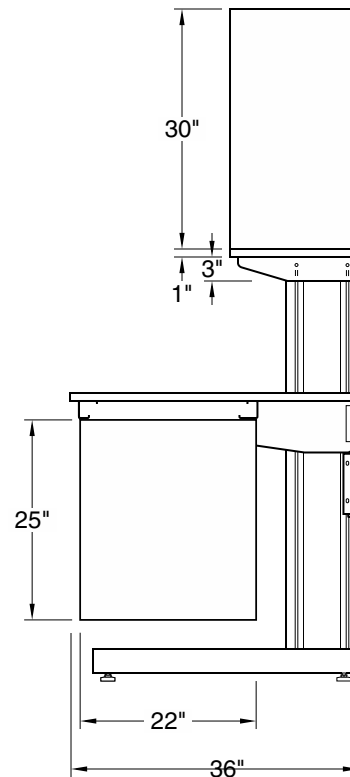

36" Deep Workstation

Dimensions - Mobile Cabinets

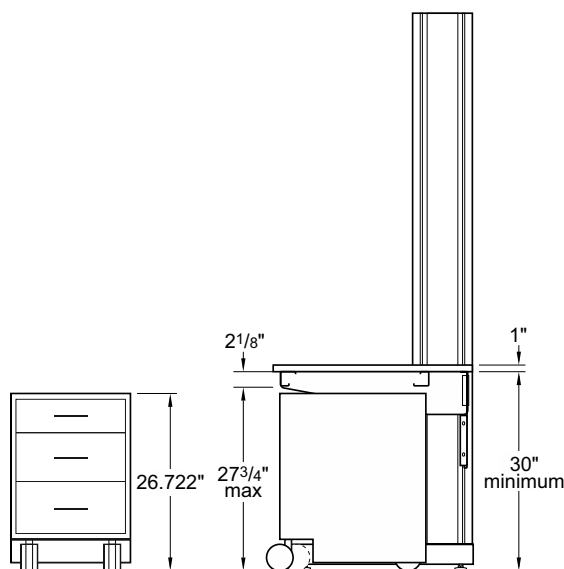

Sitting Height Mobile Cabinet

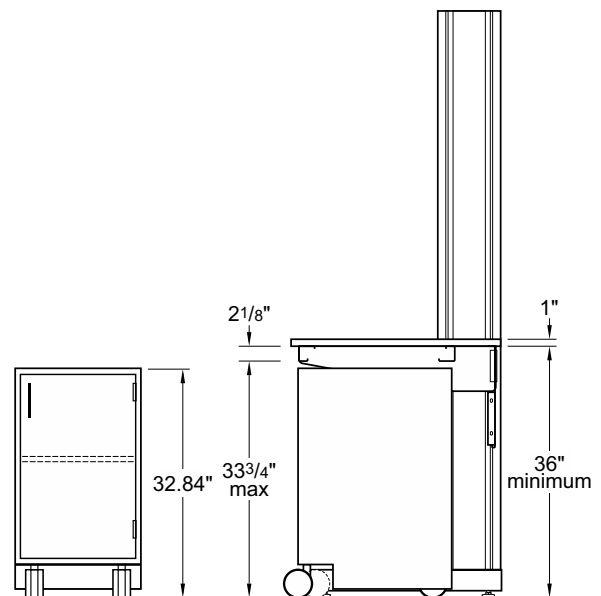

Standing Height Mobile Cabinet

Typical Installations



Typical Installations



Kewaunee Scientific Corporation is dedicated to manufacturing high quality products for the laboratory marketplace. We offer **Total Laboratory Solutions, Innovative Designs, and Technological Expertise** with a worldwide distribution network to provide laboratories that are truly World Class.

Laboratory Products from Kewaunee®:

ALPHA® – Adaptable Casework System

ALPHA Columns – Expandable Workstations

ALPHA Overhead Carrier Systems

BasikBench® – Welded C-Leg Bench

DetectAir – Filtered/Ductless Fume Hoods

EarthLine® – Environmentally Friendly Casework

Enterprise® – Moveable Workstations

Evolution® – Column Based Workstations

Interceptor® – Biological Safety Cabinet

Interceptor® – Laminar Flow Cabinet

Kemresin® – Epoxy Resin Counters & Sinks

Kewaunee Matrix® – Educational Stations

Research Collection® – Steel Casework

Signature® Series – Wood Casework

Spektrum – Laminate Architectural Millwork

Sturdilite® – Flexible Pedestal System

Supreme Air® – Fume Hoods

For our complete product offering, specifications, catalogs, brochures, case studies, and dealer list, go to www.kewaunee.com, or contact your local sales representative directly.



Kewaunee, Alpha, Basic Bench, EarthLine, Enterprise, Evolution, Interceptor, Kemresin, Kewaunee Matrix, Research Collection, Signature, Sturdilite, and Supreme Air are registered trademarks of Kewaunee Scientific Corporation

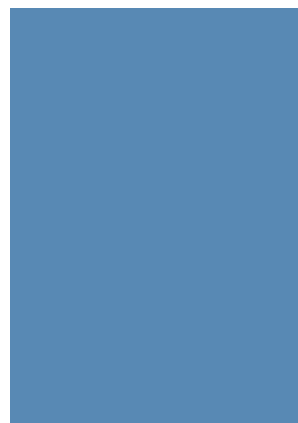

P.O. Box 1842 • Statesville, NC 28687-1842
Phone: (704) 873-7202 • Fax: (704) 873-5160
E-mail: kscmarketing@kewaunee.com
Web Site: www.kewaunee.com

Kewaunee Labway India Pvt. Ltd.
No. CA-9A, 2nd Floor, Jigani Link Road
Jigani, Bangalore 562 106, India
Phone: 9180-27826725 • Fax: 9180-27826724
Web Site: www.kewaunee.in

Kewaunee Labway Asia Pte. Ltd.
194 Pandan Loop, #06-22
Pantech Business Hub, Singapore 128 383
Phone: 65-6773-0288 • Fax: 65-6773-2322