

TruView Venturi Fume Hood

V56F...

Teaching/Demonstration Bench Hood with Combination Sash — Double-sided

(indicate fittings/fixtures required)
(hole plugged if no fitting specified)

(indicate fittings/fixtures required)
(hole plugged if no fitting specified)

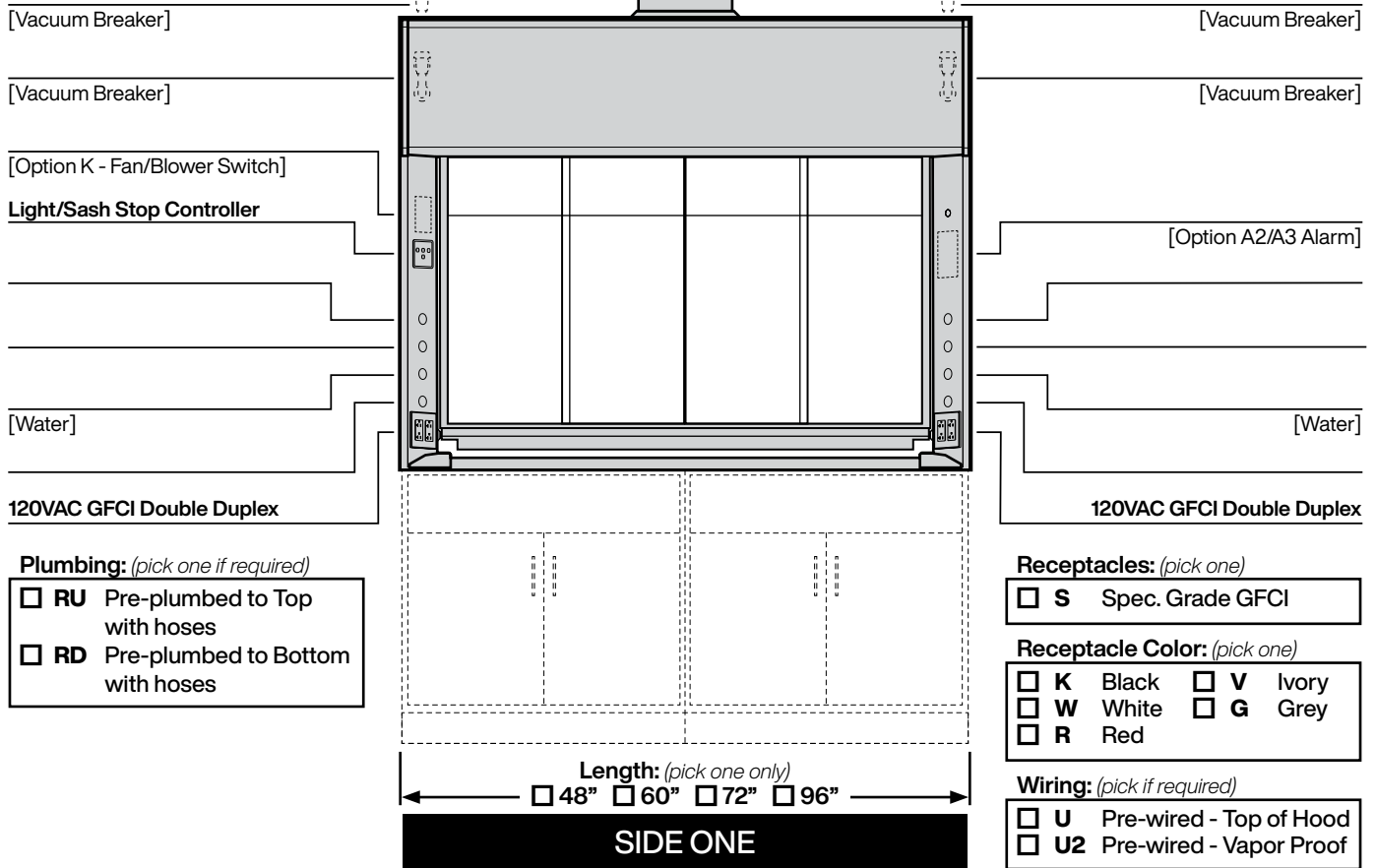

Required Options: (pick from each group)

Rear Window Configuration (pick one)

- SB** Solid Back Wall & Baffles
- CB** Glass Back Wall & Baffles

Interior Liner Material (pick one)

- G** Kemglass (Fiberglass Reinforced Polyester)

Sash Frame (pick one)

- N** Frameless
- M** Powder Coated Steel Frame
- S** Type 304L Stainless Steel Frame

Sash Glass (pick one)

- G1** Laminated Safety Glass
- G2** Tempered Safety Glass

Service Fitting Valve Type (pick one)

- F4** Front Load (Watersaver or FAR)

Hood Configuration (pick one)

- SA** Stand Alone (Free standing)
- LE** Left End (Left end of run)
- RE** Right End (Right end of run)
- AD** Add-on (Middle of run)

V Modified By-pass for VAV Control System

Controller Manf: _____

Model: _____ Minimum CFM:

Add-on Options: (pick all required)

- N1** Solid Left Window
- N2** Solid Right Window
- N3** Solid L & R Window (Kemglass panel w/frame)
(pick only one)
- A2** Air Alert 600 Alarm (pick only one)
- A3** Air Alert 300 Alarm (pick only one)
- L** Sash Stop Label
- D** Distillation Rack - Preparation
- T** Tissue Screen
- K** Fan/Blower Switch - (1 hp motor rated)
- O** Stainless Steel Airfoil - Type 304L
- O2** Stainless Steel Airfoil - Type 316L
- Q** Stainless Steel Sash Pulls
- C** Stainless Steel Duct Collar
- R1** Auto Sash Return (pick only one)
- R3** Proximity Sash Operator (pick only one)

Overall Length	Back Config	Hood Sash Liner Frame	Sash Glass	Service Fittings	Electrical Fixtures	Hood Config	Add-on Options (separated by commas)	COLOR	ITEM NO.	QUANTITY
V56F	<input type="checkbox"/>	<input checked="" type="checkbox"/> CB	<input checked="" type="checkbox"/> G	<input type="checkbox"/>	<input type="checkbox"/>	<input type="checkbox"/>	F4 , _____, _____, _____			

TruView Venturi Fume Hood

V56F...

Teaching/Demonstration Bench Hood with Vertical Rising Sash — Double-sided

(indicate fittings/fixtures required)
(hole plugged if no fitting specified)

(indicate fittings/fixtures required)
(hole plugged if no fitting specified)

[Vacuum Breaker]

[Vacuum Breaker]

[Vacuum Breaker]

[Vacuum Breaker]

[Option K - Fan/Blower Switch]

Light/Sash Stop Controller

[Option A1/A3 Alarm]

[Water]

[Water]

120VAC GFCI Double Duplex

120VAC GFCI Double Duplex

Plumbing: (pick one if required)

- RU** Pre-plumbed to Top with hoses
- RD** Pre-plumbed to Bottom with hoses

Receptacles: (pick one)

- S** Spec. Grade GFCI

Receptacle Color: (pick one)

- K** Black **V** Ivory
- W** White **G** Grey
- R** Red

Wiring: (pick if required)

- U** Pre-wired - Top of Hood
- U2** Pre-wired - Vapor Proof

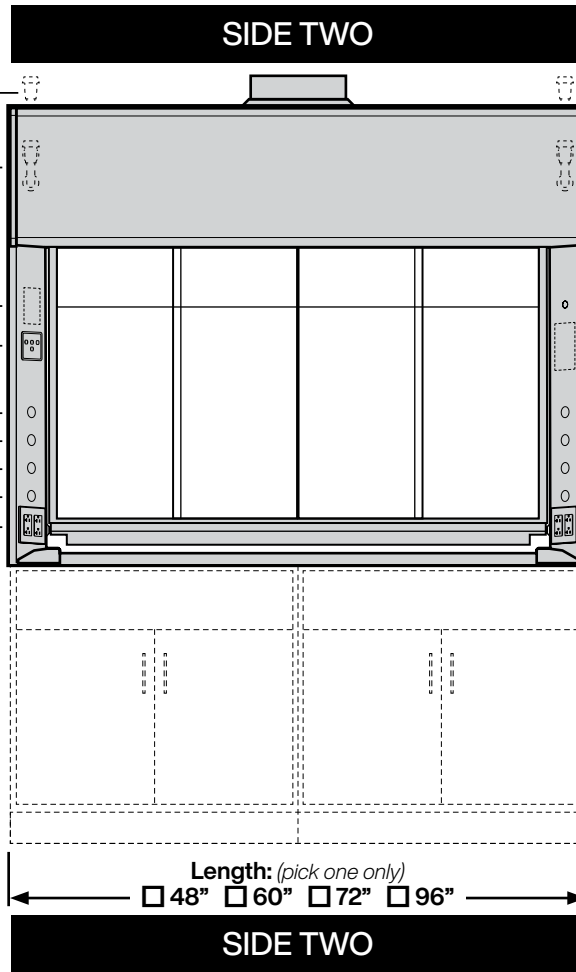

See Side One for Part Number & Options		ITEM NO.	
---	--	----------	--

Technical Information

V56F...

Airflow (CFM) Requirements — (Values in chart are for **ONE SIDE** - Double values for entire superstructure)

Face Velocity	18" High Sash Opening								Sash Closed - Panels Full Open							
	4' / 48"		5' / 60"		6' / 72"		8' / 96"		4' / 48"		5' / 60"		6' / 72"		8' / 96"	
	CFM	SP	CFM	SP	CFM	SP	CFM	SP	CFM	SP	CFM	SP	CFM	SP	CFM	SP
100 FPM	502	0.15	656	0.19	810	0.24	1118	0.16	424	0.11	567	0.14	709	0.19	995	0.13
80 FPM	401	0.10	525	0.13	648	0.16	895	0.11	339	0.07	453	0.09	568	0.12	796	0.09
60 FPM	301	0.06	394	0.07	486	0.09	671	0.06	254	0.04	340	0.05	426	0.07	597	0.05
50 FPM	251	0.04	328	0.05	405	0.07	559	0.04	212	0.03	284	0.04	355	0.05	498	0.04

Static pressures shown are for the pressure drop through the hoods only. The total pressure drop through the hood and the duct system must be calculated to select the proper exhaust fan.

Inside Depth	ANSI Z9.5 Minimum Flow Rate Flow Rate				ANSI Z9.5 Minimum Flow Rate Flow Rate			
	150 Air Changes/Hour				375 Air Changes/Hour			
	4' / 48"	5' / 60"	6' / 72"	8' / 96"	4' / 48"	5' / 60"	6' / 72"	8' / 96"
24" deep	70 CFM	90 CFM	110 CFM	145 CFM	170 CFM	220 CFM	235 CFM	365 CFM

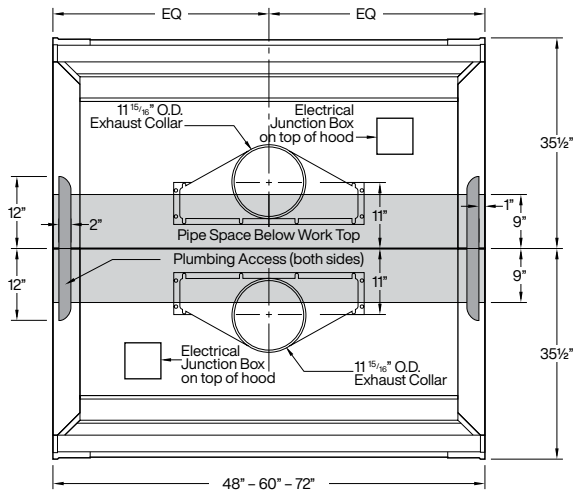

4'-5'-6' Rough-in

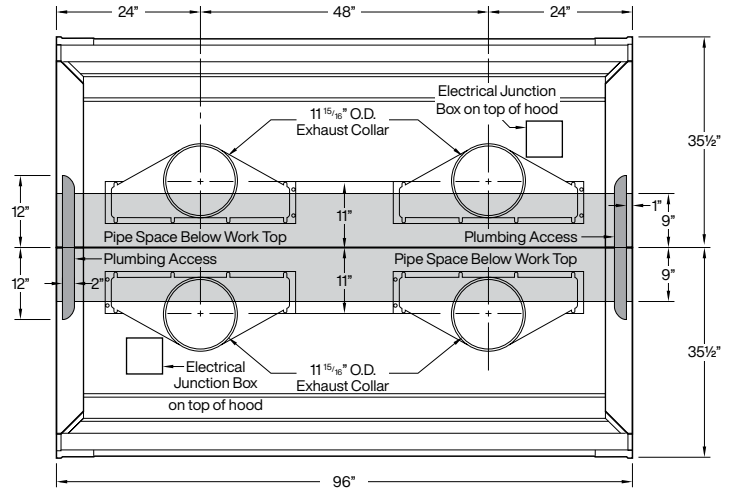

8' Rough-in

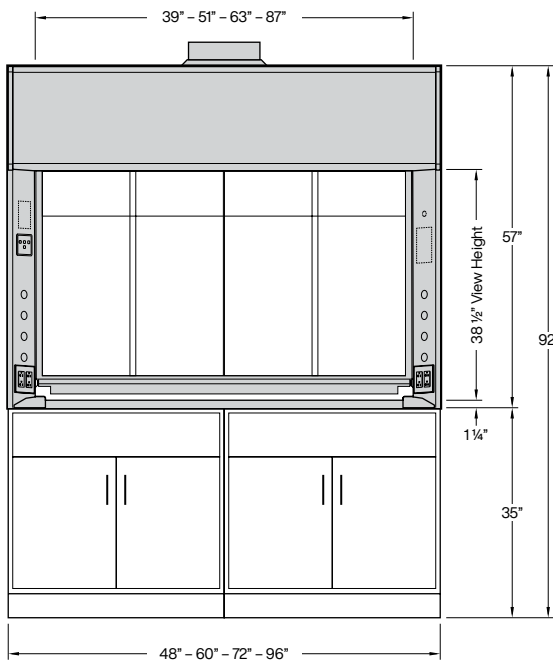

Elevation

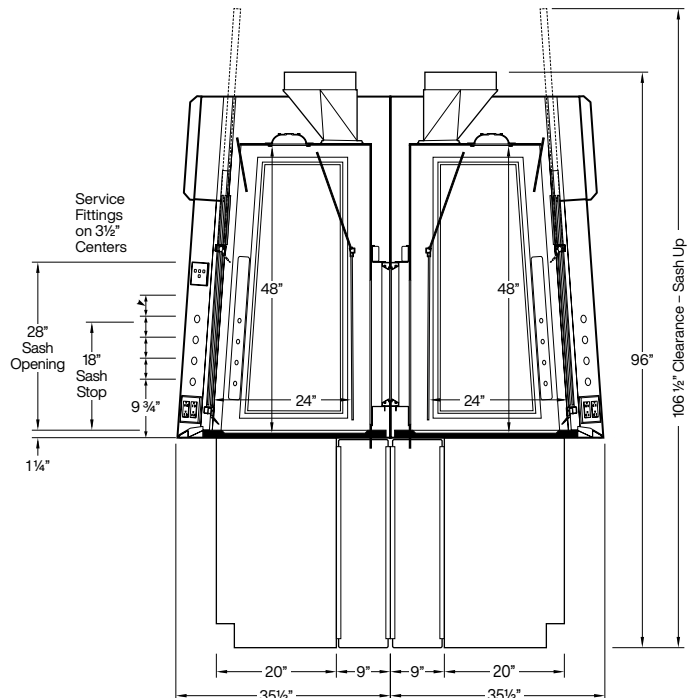

Vertical Section