

Supreme Air Venturi Fume Hood V06F 28...

General Purpose Bench Hood with Combination Vertical Rising/Horizontal Sash

(indicate fittings/fixtures required)
(hole plugged if no fitting specified)

(indicate fittings/fixtures required)
(hole plugged if no fitting specified)

[Option K - Fan/Blower Switch]

Light/Sash Stop Controller

[Water]

[Option P1 - Cord Port]

120VAC GFCI Double Duplex

[Option A2/A3 Alarm]

[Water]

[Option P1 - Cord Port]

120VAC GFCI Double Duplex

Pre-piping: (pick one if required)

- IN** Installed (no piping)
- PU** Pre-piped Up
- PD** Pre-piped Down
- SP** Pre-piped Single Point
 - Up - Left Side
 - Up - Right Side

Receptacles: (pick one)

- S** Spec. Grade GFCI
- H** Hospital Grade GFCI

Receptacle Color: (pick one)

- K** Black
- W** White
- R** Red
- V** Ivory
- G** Grey

Wiring: (pick if required)

- U** Pre-wired - Top of Hood

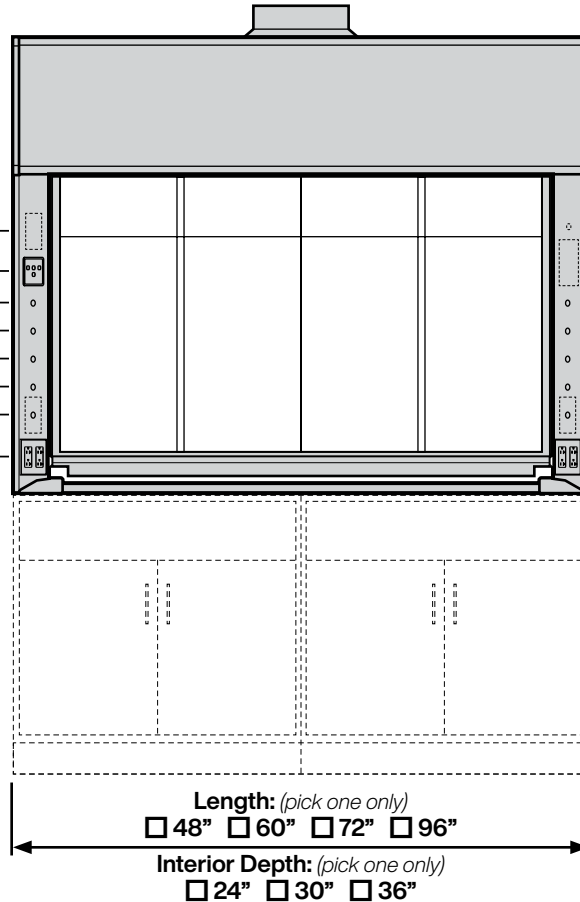

Required Options: (pick from each group)

- Interior Liner Material** (pick one)
- G** Kemglass (Fiberglass Reinforced Polyester)
 - L** Type 316L Stainless Steel
 - S** Type 304L Stainless Steel
 - T** Phenolic Resin

Sash Frame (pick one)

- M** Powder Coated Steel Frame
- S** Type 304L Stainless Steel Frame

Sash Glass (pick one)

- G1** Laminated Safety Glass
- G2** Tempered Safety Glass
- G3** Polycarbonate

Service Fitting Valve Type (pick one)

- F1** Rod Control Needle Valves
- F3** Front Load Needle Valves

- V** Modified By-pass for VAV Control System

VAV Controller Manf:

Model:

Minimum CFM:

Add-on Options: (pick all required)

- A2** Air Alert 600 Alarm
- A3** Air Alert 300 Alarm
- L** Sash Stop Label

- D** Distillation Rack - Preparation
- E** Fire Suppression System

- T** Tissue Screen
- P1** Cord Ports - one in each post

- B1** Vapor Proof Light
- B2** Explosion Proof Light
- K** Fan/Blower Switch - (1 hp motor rated)

- O** Stainless Steel Airfoil - Type 304L
- O2** Stainless Steel Airfoil - Type 316L
- Q** Stainless Steel Sash Pulls
- C** Stainless Steel Duct Collar

- R1** Auto Sash Return
- R3** Proximity Sash Operator

V06F28	Sash Height	Inside Depth	Overall Length	Hood Liner	Sash Frame	Sash Glass	Service Fittings	Electrical Fixtures	Add-on Options (separated by commas)	COLOR	ITEM NO.	QUANTITY
<input type="checkbox"/> <input type="checkbox"/>	<input type="checkbox"/> <input type="checkbox"/>	<input type="checkbox"/> <input type="checkbox"/>	<input type="checkbox"/> <input type="checkbox"/>	<input type="checkbox"/> <input type="checkbox"/>	<input type="checkbox"/> <input type="checkbox"/>	<input type="checkbox"/> <input type="checkbox"/>	<input type="checkbox"/> <input type="checkbox"/>	<input type="checkbox"/> <input type="checkbox"/>				

Technical Information

V06F 28...

Airflow (CFM) Requirements

Face Velocity	18" High Sash Opening							
	4' / 48"		5' / 60"		6' / 72"		8' / 96"	
	CFM	SP	CFM	SP	CFM	SP	CFM	SP
100 FPM	502	0.15	656	0.19	810	0.24	1118	0.16
80 FPM	401	0.10	525	0.13	648	0.16	895	0.11
60 FPM	301	0.06	394	0.07	486	0.09	671	0.06
50 FPM	251	0.04	328	0.05	405	0.07	559	0.04

Face Velocity	Sash Closed - Panels Full Open							
	4' / 48"		5' / 60"		6' / 72"		8' / 96"	
	CFM	SP	CFM	SP	CFM	SP	CFM	SP
100 FPM	424	0.11	567	0.14	709	0.19	995	0.13
80 FPM	339	0.07	453	0.09	568	0.12	796	0.09
60 FPM	254	0.04	340	0.05	426	0.07	597	0.05
50 FPM	212	0.03	284	0.04	355	0.05	498	0.04

Static pressures shown are for the pressure drop through the hoods only. The total pressure drop through the hood and the duct system must be calculated to select the proper exhaust fan.

ANSI Z9.5 Minimum Flow Rate Flow Rate

Inside Depth	150 Air Changes/Hour				375 Air Changes/Hour			
	4' / 48"	5' / 60"	6' / 72"	8' / 96"	4' / 48"	5' / 60"	6' / 72"	8' / 96"
24" deep	80 CFM	100 CFM	120 CFM	170 CFM	190 CFM	240 CFM	300 CFM	410 CFM
30" deep	90 CFM	120 CFM	150 CFM	200 CFM	230 CFM	290 CFM	360 CFM	500 CFM
36" deep	110 CFM	140 CFM	170 CFM	240 CFM	270 CFM	350 CFM	430 CFM	590 CFM

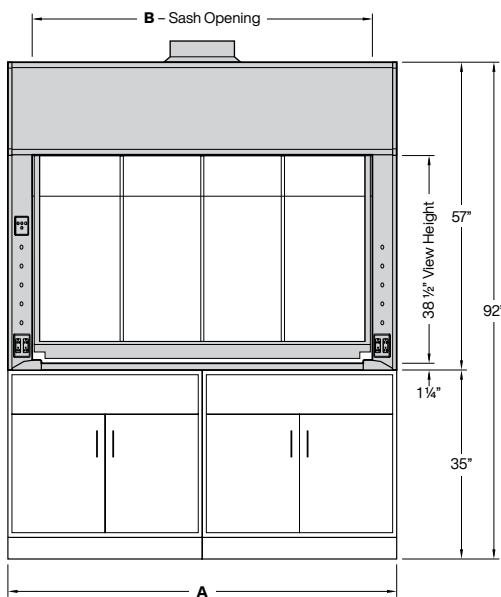
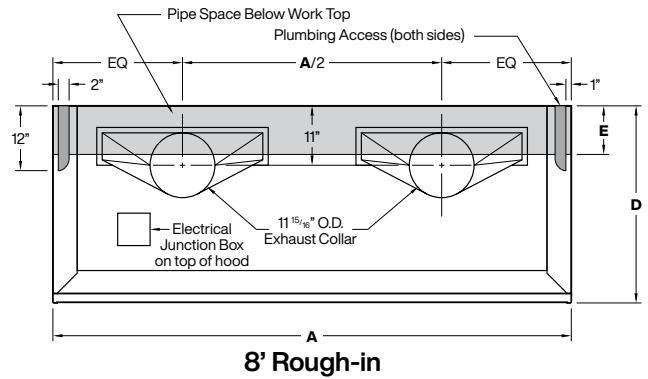
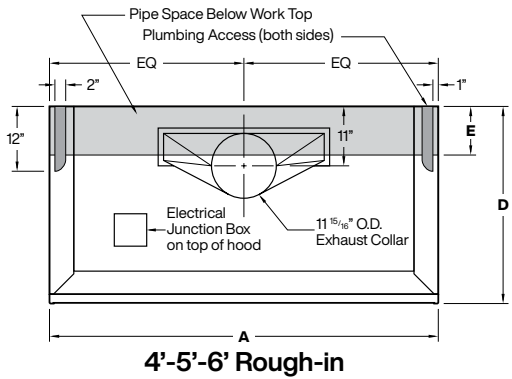

Elevation

Dimensions - Length				
A	48"	60"	72"	96"
B	39"	51"	63"	87"

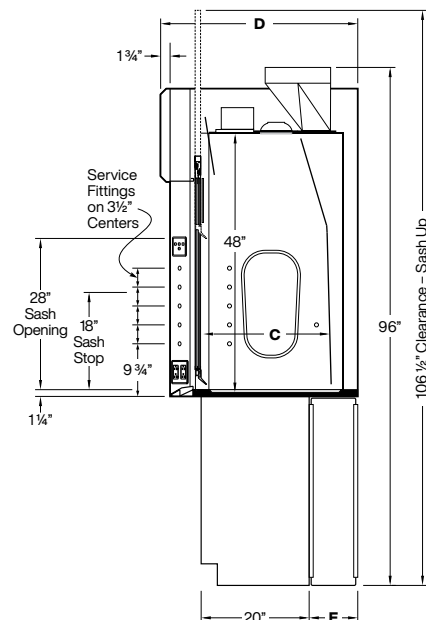

Vertical Section

Dimensions - Depth			
C	24"	30"	36"
D	36 1/2"	42 1/2"	48 1/2"
E	9"	15"	21"