

Supreme Air Venturi Fume Hood

V90F63...

Distillation Hood with Vertical Rising Sash

(indicate fittings/fixtures required)
(hole plugged if no fitting specified)

(indicate fittings/fixtures required)
(hole plugged if no fitting specified)

[Option K - Fan/Blower Switch]

Light/Sash Stop Controller



[Water]

[Option P1 - Cord Port]

120VAC GFCI Double Duplex

Pre-piping: (pick one if required)

- IN** Installed (no piping)
- PU** Pre-piped Up
- PD** Pre-piped Down
- SP** Pre-piped Single Point
 - Up - Left Side
 - Up - Right Side

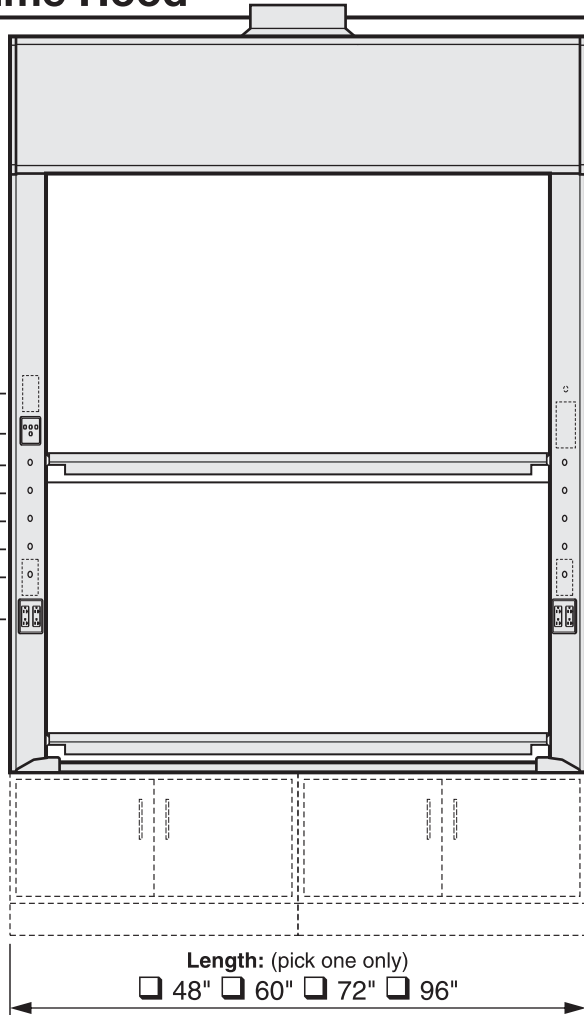

[Option A1/A3 Alarm]

[Water]

[Option P1 - Cord Port]

120VAC GFCI Double Duplex

Receptacles: (pick one)

- S** Spec. Grade GFCI
- H** Hospital Grade GFCI

Receptacle Color: (pick one)

- K** Black
- V** Ivory
- W** White
- G** Grey
- R** Red

Wiring: (pick if required)

- U** Pre-wired - Top of Hood

Length: (pick one only)
 48" 60" 72" 96"
Interior Depth: (pick one only)
 24" 30" 36"

Required Options: (pick one from each group)

- Interior Liner Material** (pick one)
- G** Kemglass (Fiberglass Reinforced Polyester)
 - L** Type 316L Stainless Steel
 - S** Type 304L Stainless Steel
 - T** Phenolic Resin
- Sash Frame** (pick one)
- N** Frameless
 - M** Powder Coated Steel Frame
 - S** Type 304L Stainless Steel Frame
- Sash Glass** (pick one)
- G1** Laminated Safety Glass
 - G2** Tempered Safety Glass
 - G3** Polycarbonate
- Service Fitting Valve Type** (pick one)
- F1** Rod Control Needle Valves
 - F3** Front Load Needle Valves

V Modified By-pass for VAV Control System

VAV Controller Manf: _____

Model: _____

Minimum CFM:

Add-on Options: (pick all required)

- A1** Air Alert 600 Alarm
- A3** Air Alert 300 Alarm
- L** Sash Stop Label
- D** Distillation Rack - Preparation
- E** Fire Suppression System
- S** Safety Shield
- T** Tissue Screen
- P1** Cord Ports - one in each post
- B1** Vapor Proof Light
- B2** Explosion Proof Light
- K** Fan/Blower Switch - (1hp motor rated)
- O** Stainless Steel Airfoil - Type 304L
- O2** Stainless Steel Airfoil - Type 316L
- Q** Stainless Steel Sash Pulls
- C** Stainless Steel Duct Collar
- R3** Proximity Sash Operator (closes both sashes)

Sash Height	Inside Depth	Overall Length	Hood Liner	Sash Frame	Sash Glass	Service Fittings	Electrical Fixtures	Add-on Options (separated by commas)	COLOR	ITEM NO.	QUANTITY
V90F 28	<input type="text"/>	<input type="text"/>	<input type="text"/>	<input type="text"/>	<input type="text"/>	<input type="text"/>	<input type="text"/>	_____			

Technical Information

V90F63...

Airflow (CFM) Requirements

Face Velocity	28" High Upper Sash Opening								18" High Lower Sash Opening							
	4'-0" / 48"		5'-0" / 60"		6'-0" / 72"		8'-0" / 96"		4'-0" / 48"		5'-0" / 60"		6'-0" / 72"		8'-0" / 96"	
	CFM	SP	CFM	SP	CFM	SP	CFM	SP	CFM	SP	CFM	SP	CFM	SP	CFM	SP
120 FPM	992	0.56	1297	0.70	1602	0.88	2212	0.61	655	0.25	857	0.32	1058	0.40	1461	0.28
100 FPM	827	0.39	1081	0.50	1335	0.62	1843	0.43	545	0.18	714	0.23	882	0.28	1218	0.19
80 FPM	661	0.26	865	0.32	1068	0.41	1475	0.28	435	0.12	571	0.15	706	0.19	974	0.15

Static pressures shown are for the pressure drop through the hoods only. The total pressure drop through the hood and the duct system must be calculated to select the proper exhaust fan.

ANSI Z9.5 Minimum Flow Rate

Inside Depth	150 Air Changes/Hour				375 Air Changes/Hour			
	4'-0" / 48"	5'-0" / 60"	6'-0" / 72"	8'-0" / 96"	4'-0" / 48"	5'-0" / 60"	6'-0" / 72"	8'-0" / 96"
24" deep	120 CFM	160 CFM	200CFM	270 CFM	300CFM	390CFM	480CFM	660CFM
30" deep	150 CFM	200CFM	240CFM	330CFM	370 CFM	480CFM	590CFM	820CFM
36" deep	180 CFM	230 CFM	290CFM	390CFM	440CFM	570 CFM	710 CFM	970 CFM

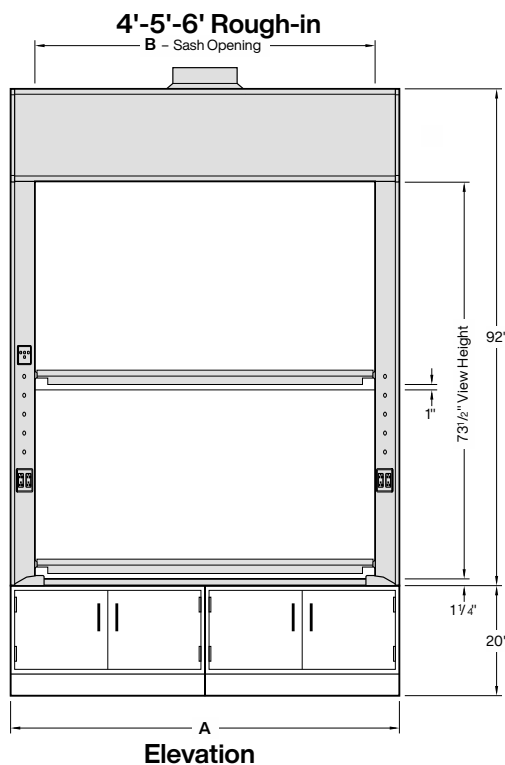
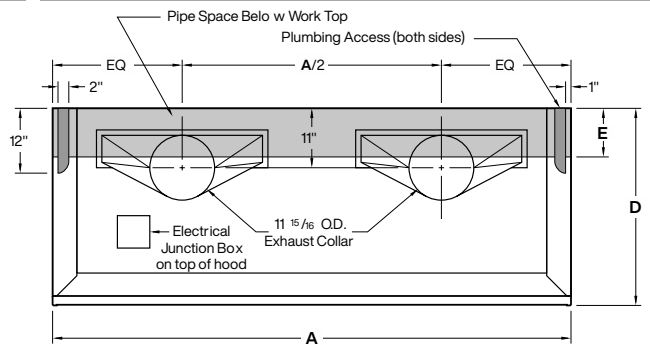
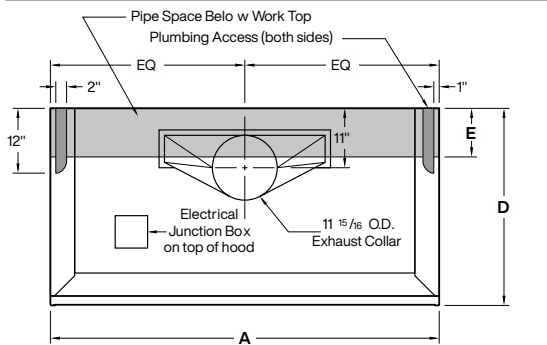

Dimensions - Length				
A	48"	60"	72"	96"
B	39"	51"	63"	87"

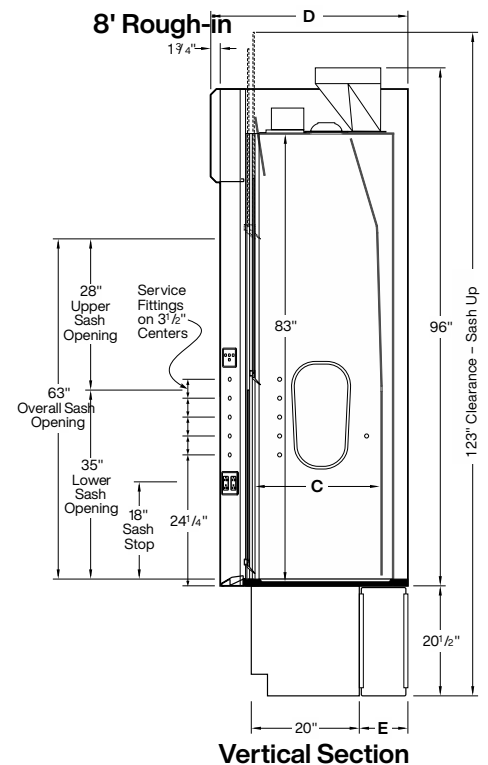

Dimensions - Depth			
C	24"	30"	36"
D	36 1/2"	42 1/2"	48 1/2"
E	9"	15"	21"