

# TruView Venturi Fume Hood

# V57F...

Teaching/Demonstration ADA Bench Hood with Vertical Rising Sash — Double-sided

(indicate fittings/fixtures required)  
(hole plugged if no fitting specified)

(indicate fittings/fixtures required)  
(hole plugged if no fitting specified)

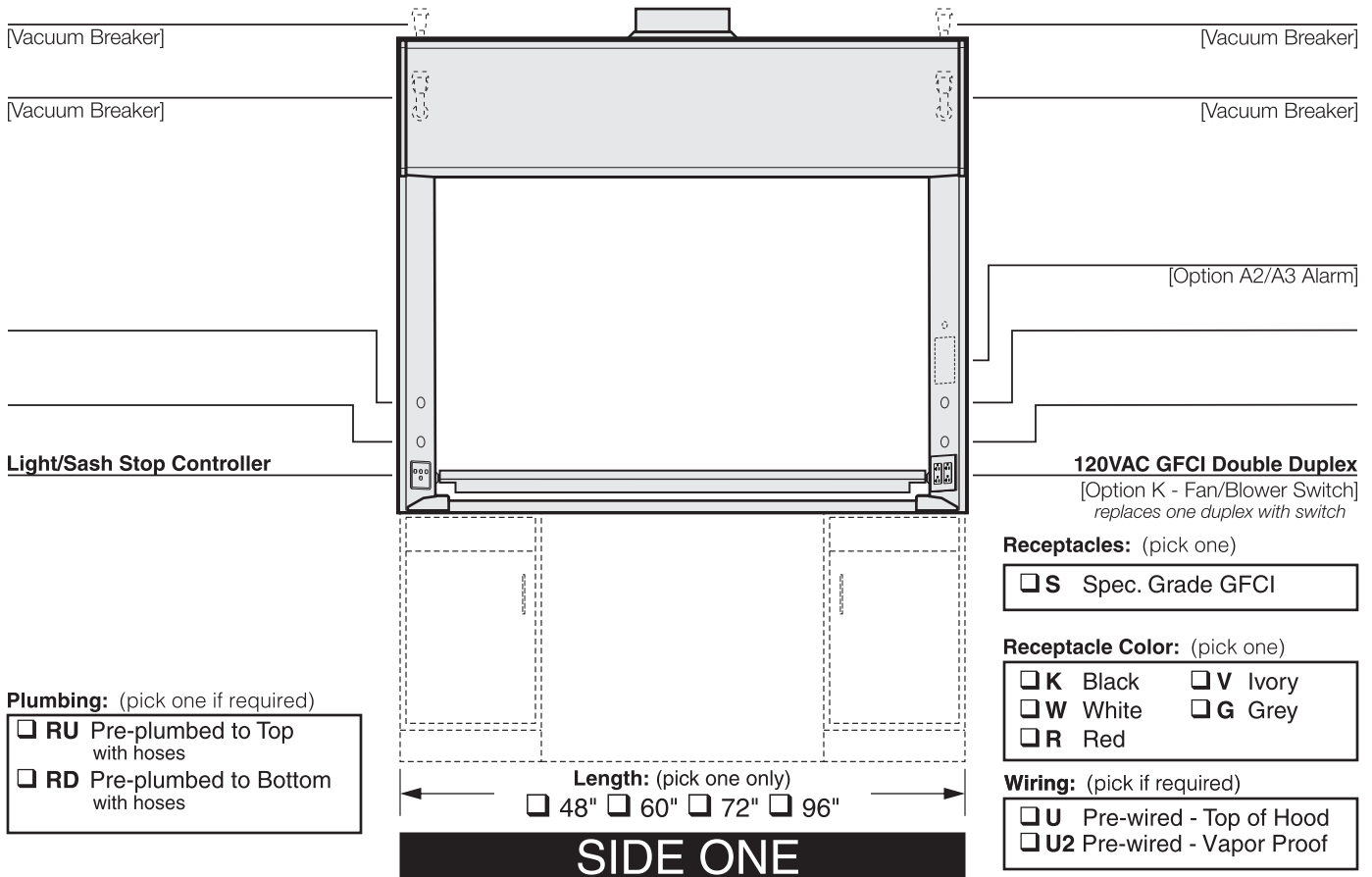

**Required:** (pick one from each group – will be applied to both sides)

**Options:** (pick all required – will be applied to both sides)

**Back Configuration** (pick one)

**CB** Glass Back Wall & Baffles

**Interior Liner Material** (pick one)

**G** Kemglass (Fiberglass Reinforced Polyester)

**Sash Frame** (pick one)

**N** Frameless  
 **M** Powder Coated Steel Frame  
 **S** Type 304L Stainless Steel Frame

**Sash Glass** (pick one)

**G1** Laminated Safety Glass  
 **G2** Tempered Safety Glass

**Service Fitting Valve Type** (pick one)

**F4** ADA (FAR)  
 **F5** ADA (Watersaver)

**Hood Configuration** (pick one)

**SA** Stand Alone (Free standing)  
 **EU** End Unit (Side One Right End – Side Two Left End)  
 **AD** Add-on (Middle of run)

**N1** Solid Left Window (Kemglass panel w/frame) — (pick one only)  
 **N2** Solid Right Window (Kemglass panel w/frame) — (pick one only)  
 **N3** Solid L & R Window (Kemglass panel w/frame) — (pick one only)

**A1** Air Alert 600 Alarm — (pick one only)  
 **A3** Air Alert 300 Alarm — (pick one only)  
 **L** Sash Stop Label

**D** Distillation Rack Preparation

**T** Tissue Screen

**K** Fan/Blower Switch (1hp motor rated)

**O** Stainless Steel Airfoil - Type 304L  
 **O2** Stainless Steel Airfoil - Type 316L  
 **Q** Stainless Steel Sash Pulls  
 **C** Stainless Steel Duct Collar

**V** Modified By-pass for VAV Control System  
Controller Manf: \_\_\_\_\_  
Model: \_\_\_\_\_ Minimum CFM:

**R1** Auto Sash Return — (pick one only)  
 **R3** Proximity Sash Operator — (pick one only)

Overall Length	Back Config.	Hood Liner	Sash Frame	Sash Glass	Service Fittings	Electrical Fixtures	Hood Config.	Options (separated by commas)	COLOR	ITEM NO.	QUANTITY
V57F	<input type="checkbox"/>	<input checked="" type="checkbox"/> CB	<input checked="" type="checkbox"/> G	<input type="checkbox"/>	<input type="checkbox"/>	<input type="checkbox"/>	<input type="checkbox"/>				

# TruView Venturi Fume Hood

# V57F...

Teaching/Demonstration ADA Bench Hood with Vertical Rising Sash — Double-sided

(indicate fittings/fixtures required)  
(hole plugged if no fitting specified)

(indicate fittings/fixtures required)  
(hole plugged if no fitting specified)

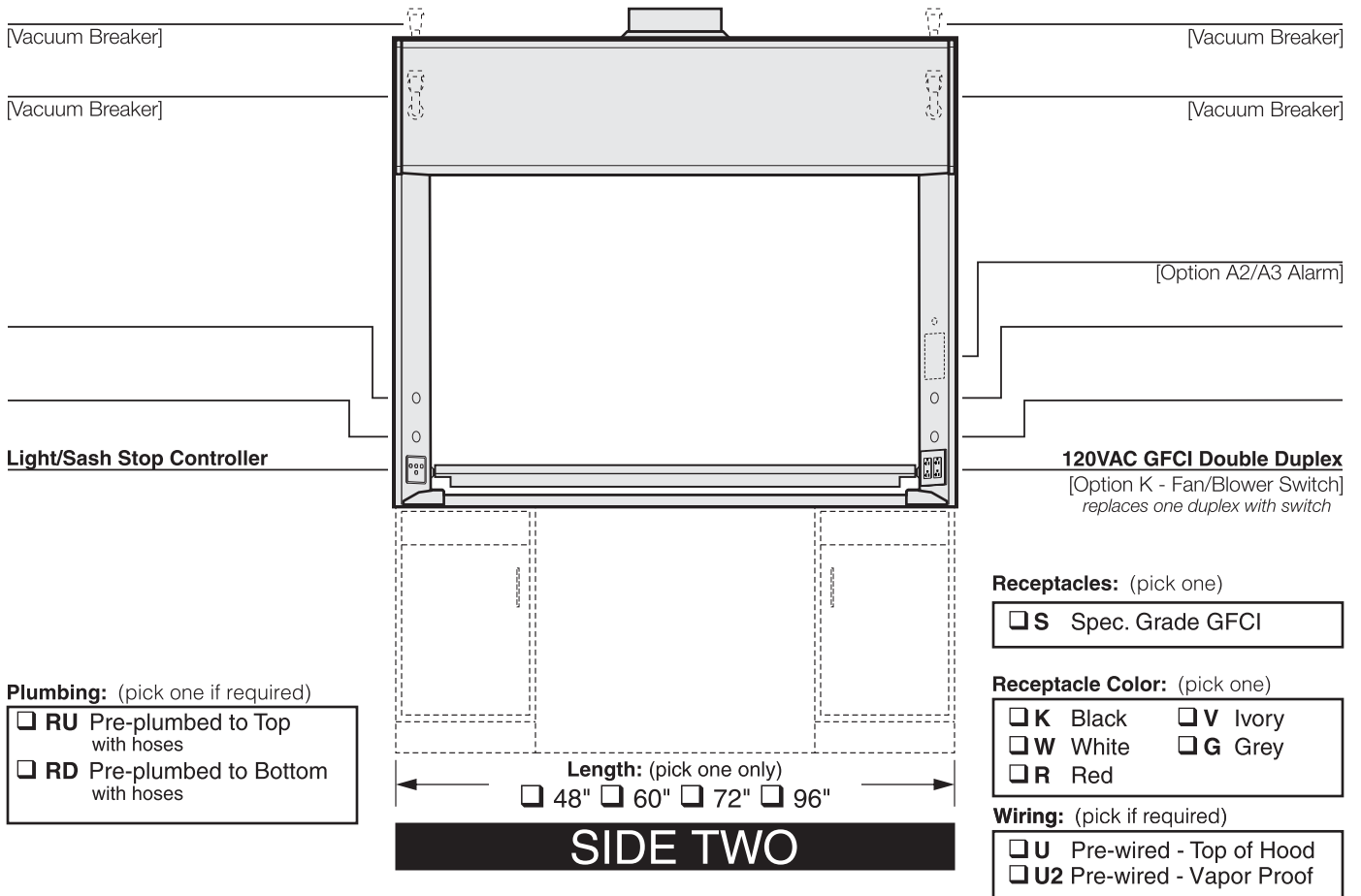

<b>See Side One for Part Number &amp; Options</b>	ITEM NO.	

# Technical Information

# V57F...

## Airflow (CFM) Requirements (Values in chart are for ONE SIDE - Double values for entire superstructure)

Face Velocity	28" High Sash Opening								18" High Sash Opening							
	4'-0" / 48"		5'-0" / 60"		6'-0" / 72"		8'-0" / 96"		4'-0" / 48"		5'-0" / 60"		6'-0" / 72"		8'-0" / 96"	
	CFM	SP	CFM	SP	CFM	SP	CFM	SP	CFM	SP	CFM	SP	CFM	SP	CFM	SP
100 FPM	772	0.35	1010	0.44	1247	0.55	1722	0.38	502	0.15	656	0.19	810	0.24	1118	0.16
80 FPM	618	0.23	808	0.29	998	0.36	1378	0.25	401	0.10	525	0.13	648	0.16	895	0.11
60 FPM	464	0.13	606	0.16	749	0.21	1034	0.14	301	0.06	394	0.07	486	0.09	671	0.06
50 FPM	386	0.09	506	0.12	624	0.15	861	0.10	251	0.04	328	0.05	405	0.07	559	0.04

Static pressures shown are for the pressure drop through the hoods only. The total pressure drop through the hood and the duct system must be calculated to select the proper exhaust fan.

## ANSI Z9.5 Minimum Flow Rate (Values in chart are for ONE SIDE - Double values for entire superstructure)

Inside Depth	150 Air Changes/Hour				375 Air Changes/Hour			
	4'-0" / 48"	5'-0" / 60"	6'-0" / 72"	8'-0" / 96"	4'-0" / 48"	5'-0" / 60"	6'-0" / 72"	8'-0" / 96"
24" deep	75 CFM	100 CFM	120 CFM	155 CFM	185 CFM	235 CFM	285 CFM	390 CFM

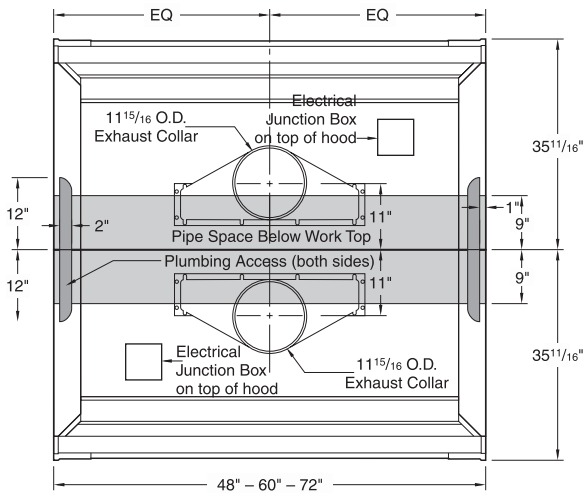

4'-5'-6' Rough-in

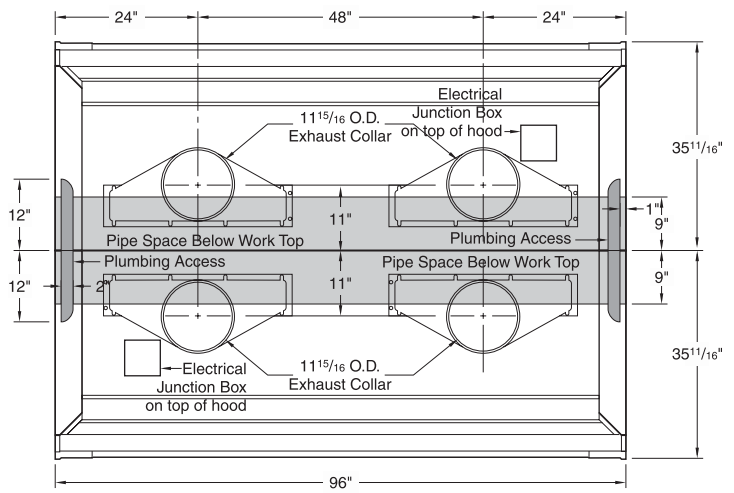

8' Rough-in

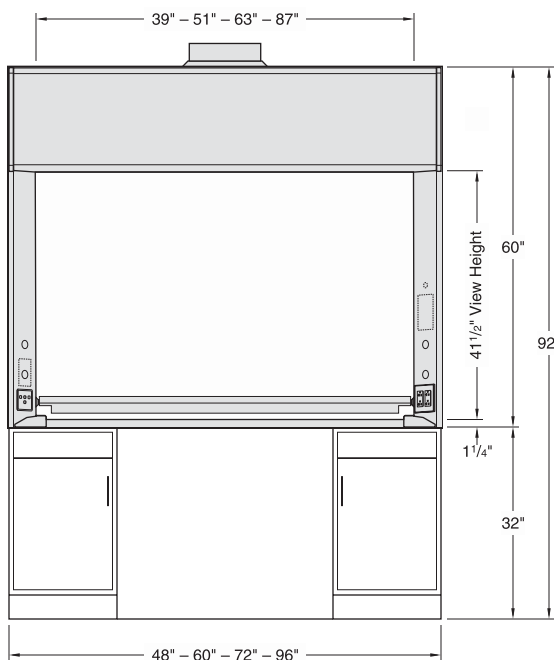

Elevation

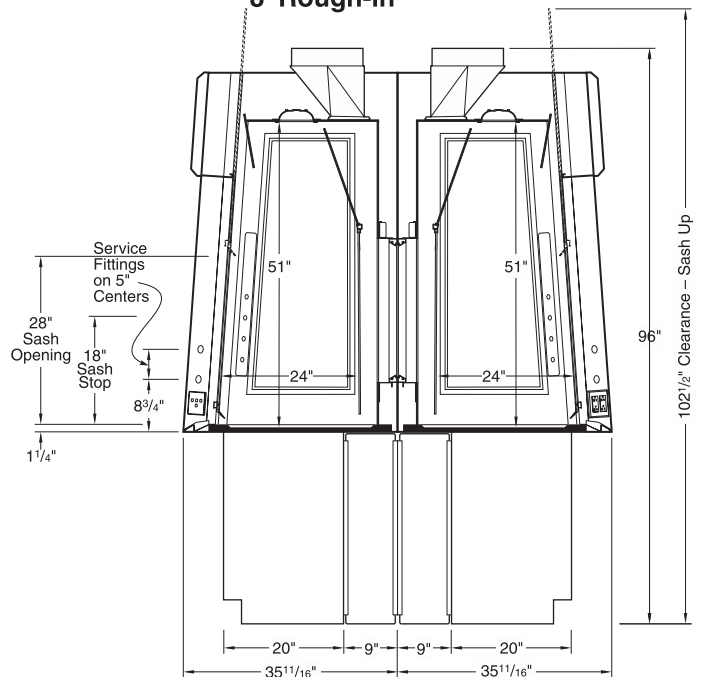

Vertical Section